

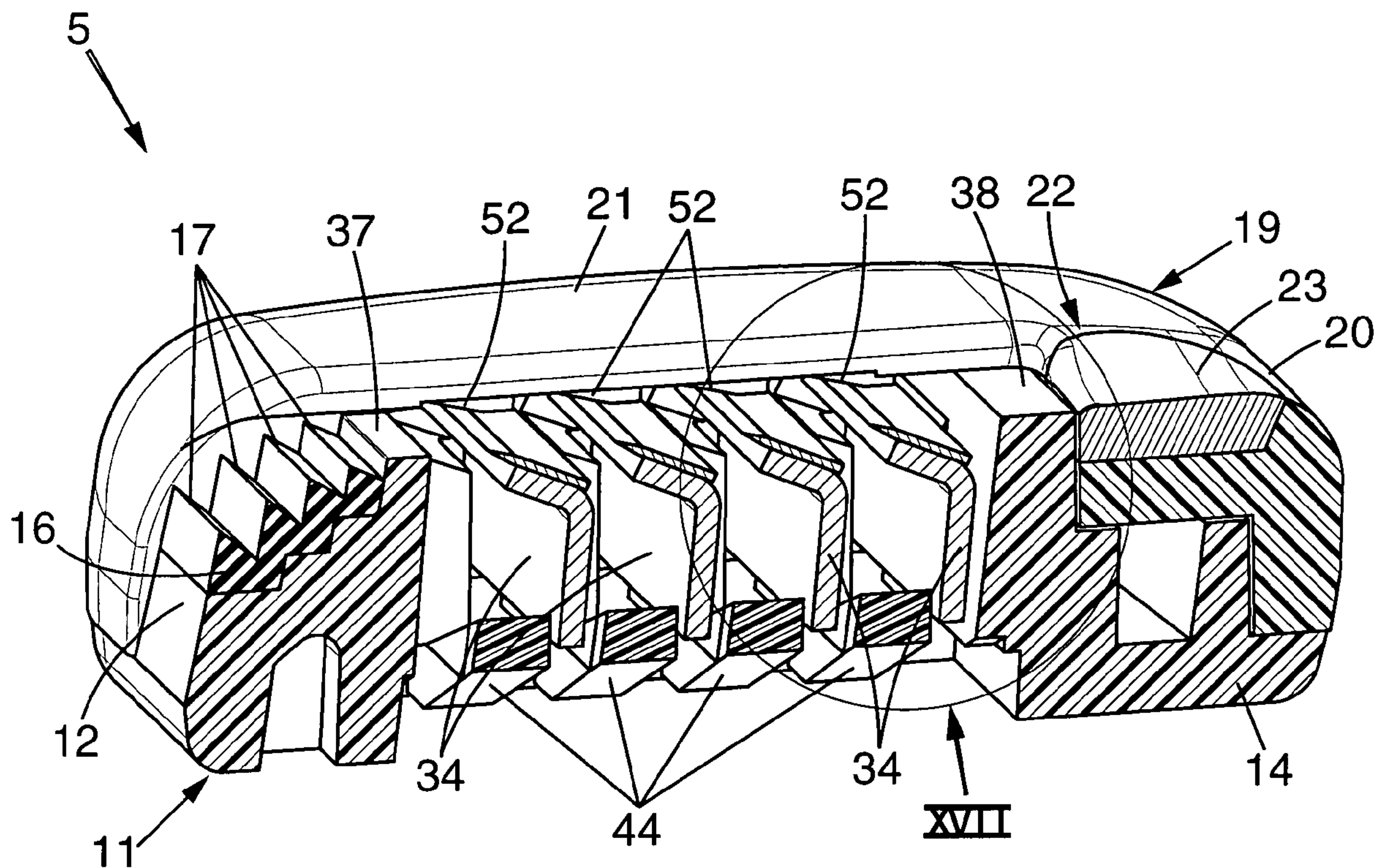

(86) Date de dépôt PCT/PCT Filing Date: 2006/06/20
 (87) Date publication PCT/PCT Publication Date: 2007/12/27
 (45) Date de délivrance/Issue Date: 2012/01/03
 (85) Entrée phase nationale/National Entry: 2008/12/17
 (86) N° demande PCT/PCT Application No.: EP 2006/005905
 (87) N° publication PCT/PCT Publication No.: 2007/147420

(51) Cl.Int./Int.Cl. *B26B 21/22* (2006.01)
 (72) Inventeurs/Inventors:
 BOZIKIS, IOANNIS, GR;
 EFTHIMIADIS, DIMITRIS, GR;
 GRATSIAS, SPIROS, GR
 (73) Propriétaire/Owner:
 BIC-VIOLEX S.A., GR
 (74) Agent: NORTON ROSE OR S.E.N.C.R.L., S.R.L./LLP

(54) Titre : TETE DE LAME DE RASOIR ET RASOIR DE SECURITE COMPRENANT UNE TELLE LAME
 (54) Title: RAZOR BLADE UNIT HEAD AND SAFETY RAZOR INCLUDING SUCH A BLADE UNIT



(57) Abrégé/Abstract:

Razor blade unit (5) including a frame (11, 19) and blades (25) movably mounted in the frame, each blade being elastically biased toward a rest position where the upper face of each blade bears against upper stop portions (52) of the frame, the upper face of each blade being parallel to the corresponding upper stop portions.

(12) INTERNATIONAL APPLICATION PUBLISHED UNDER THE PATENT COOPERATION TREATY (PCT)

(19) World Intellectual Property Organization
International Bureau



(43) International Publication Date
27 December 2007 (27.12.2007)

PCT

(10) International Publication Number
WO 2007/147420 A1

(51) International Patent Classification:
B26B 21/22 (2006.01)

(21) International Application Number:

PCT/EP2006/005905

(22) International Filing Date: 20 June 2006 (20.06.2006)

(25) Filing Language: English

(26) Publication Language: English

(71) Applicant (for all designated States except US): **BIC-VOLEX SA** [GR/GR]; Agiou Athanasiou, GR-145 69 Anixi, Attiki (GR).

(72) Inventors; and

(75) Inventors/Applicants (for US only): **BOZIKIS, Ioannis** [GR/GR]; 99 Dimitrakopoulou, GR-117 41 Koukaki Athens (GR). **EFTHIMIADIS, Dimitris** [GR/GR]; 10 Papachristoforou Str., GR-114 76 Athens (GR). **GRATSIAS, Spiros** [GR/GR]; 39 Kresnas Str., GR-113 63 Kypseli Athens (GR).

(74) Agents: **BURBAUD, Eric** et al.; Cabinet Plasseraud, 52, rue de la Victoire, F-75440 Paris Cedex 09 (FR).

(81) Designated States (unless otherwise indicated, for every kind of national protection available): AE, AG, AL, AM, AT, AU, AZ, BA, BB, BG, BR, BW, BY, BZ, CA, CH, CN, CO, CR, CU, CZ, DE, DK, DM, DZ, EC, EE, EG, ES, FI, GB, GD, GE, GH, GM, HN, HR, HU, ID, IL, IN, IS, JP, KE, KG, KM, KN, KP, KR, KZ, LA, LC, LK, LR, LS, LT, LU, LV, LY, MA, MD, MG, MK, MN, MW, MX, MZ, NA, NG, NI, NO, NZ, OM, PG, PH, PL, PT, RO, RS, RU, SC, SD, SE, SG, SK, SL, SM, SY, TJ, TM, TN, TR, TT, TZ, UA, UG, US, UZ, VC, VN, ZA, ZM, ZW.

(84) Designated States (unless otherwise indicated, for every kind of regional protection available): ARIPO (BW, GH, GM, KE, LS, MW, MZ, NA, SD, SL, SZ, TZ, UG, ZM, ZW), Eurasian (AM, AZ, BY, KG, KZ, MD, RU, TJ, TM), European (AT, BE, BG, CH, CY, CZ, DE, DK, EE, ES, FI, FR, GB, GR, HU, IE, IS, IT, LT, LU, LV, MC, NL, PL, PT, RO, SE, SI, SK, TR), OAPI (BF, BJ, CF, CG, CI, CM, GA, GN, GQ, GW, ML, MR, NE, SN, TD, TG).

Published:

— with international search report

For two-letter codes and other abbreviations, refer to the "Guidance Notes on Codes and Abbreviations" appearing at the beginning of each regular issue of the PCT Gazette.

(54) Title: RAZOR BLADE UNIT HEAD AND SAFETY RAZOR INCLUDING SUCH A BLADE UNIT

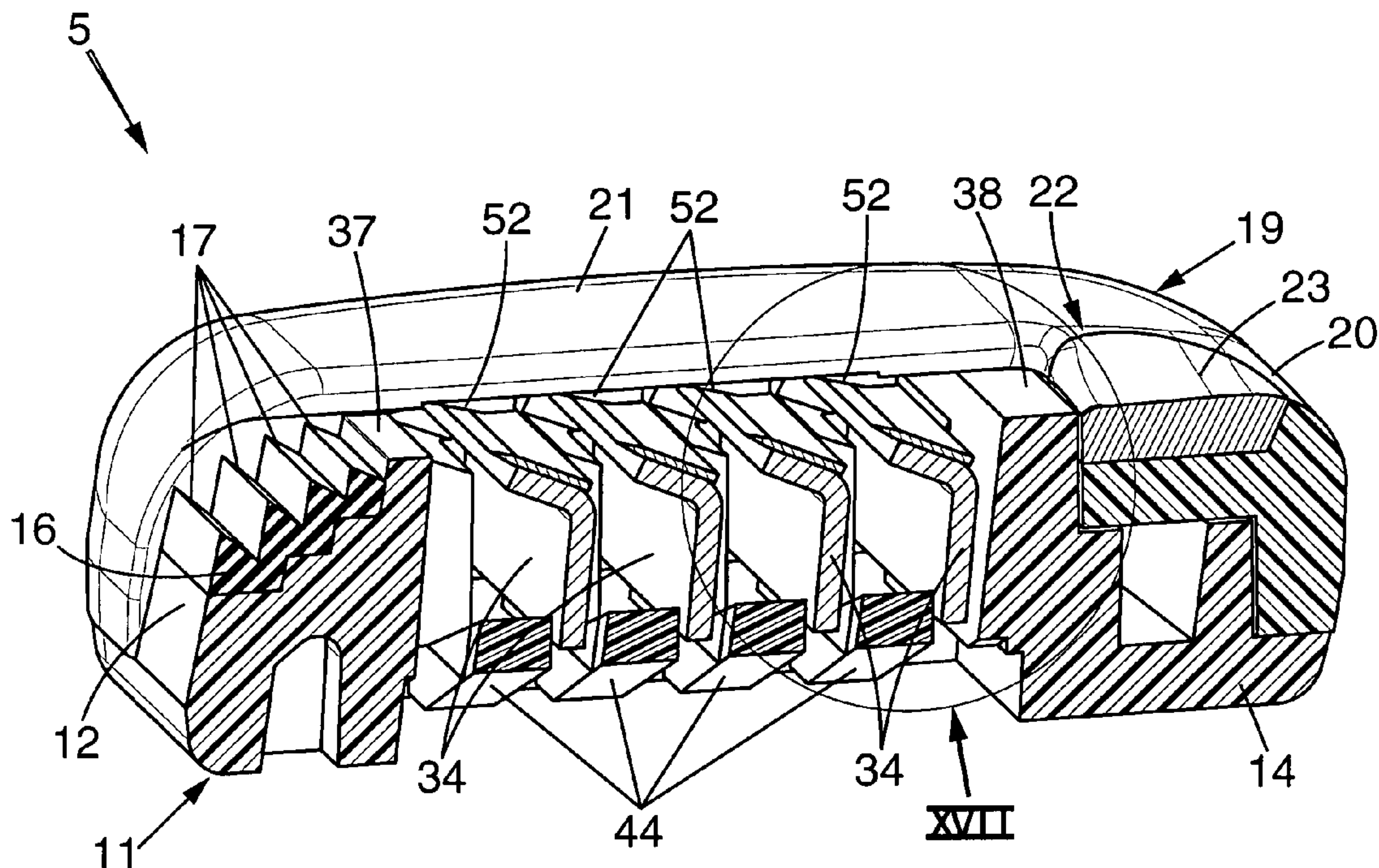

(57) Abstract: Razor blade unit (5) including a frame (11, 19) and blades (25) movably mounted in the frame, each blade being elastically biased toward a rest position where the upper face of each blade bears against upper stop portions (52) of the frame, the upper face of each blade being parallel to the corresponding upper stop portions.

**RAZOR BLADE UNIT HEAD AND SAFETY RAZOR INCLUDING SUCH A
BLADE UNIT.**

FIELD OF THE INVENTION

5 The invention relates to razor blade units and to
safety razors including such blade units.

BACKGROUND OF THE INVENTION

10 More precisely, the invention relates to a razor
blade unit including a frame and at least one blade movably
mounted in said frame, said blade including an upper face,
a lower face and a cutting edge, said frame including at
least one upper stop portion and said blade being
elastically biased toward said upper stop portion, where
said blade is in a rest position.

15 US-A-2002/0144404 discloses an example of such a
known razor blade unit, in which the cutting edges of the
blades bear against the upper stops of the frame when the
blades are in their position of maximum exposure.

20 Therefore, the cutting edges of the blades may
penetrate in the upper stop portions (which are made of
plastics in this case) and/or be damaged when the blades
are in their rest position, so that the exposure of the
blades at rest is not well defined. This, in turn, entails
a lack of precision of the shaving.

25 OBJECTS AND SUMMARY OF THE INVENTION

One objective of the present invention is to avoid
this drawback.

30 To this end, according to the invention, in a razor
blade unit of the type in question, the upper face of said
blade bears against the upper stop portion when the blade
is in the rest position, said upper face being
substantially parallel to the upper stop portion.

35 Thanks to these dispositions, the blade edge does
not penetrate in the upper stop portion and is not damaged
by the upper stop portion under the elastic bias undergone

by the blade, so that the rest position of the blade is well defined and the safety razor blade unit enables a precise shaving.

In various embodiments of the invention, one may possibly have recourse in addition to one and/or other of the following arrangements:

- the blade is movable under forces encountered during shaving and the rest position is a position of maximum exposure of the blade;
- 10 - the frame includes at least one elastic finger elastically biasing the blade toward the rest position;
 - the frame is made of synthetic material;
 - the frame is deprived of metal;
 - the upper and lower faces of the blade include
 - 15 respectively two parallel main surfaces and two tapered facets which taper toward the cutting edge, the tapered facet of the upper face bearing against the upper stop portion in the rest position and said tapered facet of the upper face being substantially parallel to the upper stop
 - 20 portion;
 - the frame includes a guard, a cap and two side portions joining the guard to the cap, the blade extending parallel to the guard and the cap between two lateral ends which are respectively near said two side portions, said
 - 25 side portions including two upper stop portions against which the two lateral ends of the blade bear respectively in the rest position, the upper face of the blade being substantially parallel said two upper stop portions;
 - the blade unit includes several parallel blades
 - 30 and the side portions include two upper stop portions for each blade, against which the two lateral ends of each blade bear respectively in the rest position, the upper face of each blade being substantially parallel to the corresponding upper stop portions;
 - 35 - the blade is slidingly mounted in two slots

which are provided respectively in the two side portions of the frame;

- the blade is borne by a bent support having a lower portion extending in a plane parallel to the slots and an upper portion extending in a plane parallel to the blade, the lower portion extending parallel to the cutting edge between two lateral portions which are slidingly mounted in the slots;

- each slot of the frame is defined between a front guide surface and a back guide surface belonging to the corresponding side portion of the frame, said front guide surface being closer to the guard and said back guide surface being closer to said cap, and said front and back guide surfaces being laterally offset with regard to one another parallel to the cutting edge of the blade;

- each lateral portion of the lower portion of the blade support has a side edge and the slot in which said side portion is slidingly mounted has its front guide surface closer to said side edge and its back guide surface further away from the side edge;

- each side portion of the frame further includes a lower stop portion which is near the front guide surface and which is disposed under the upper portion of the bent support to limit sliding of the blade and bent support away from said rest position;

- the lower stop portion is substantially parallel to the upper portion of the bent support;

- each lateral portion of the lower portion of the blade support has a side edge and said lateral portions of the lower portion of the bent support are protruding laterally from the upper portion and from the blade, each lower stop portion being offset laterally from the front guide surface, away from the corresponding lateral edge of the lower portion of the blade support;

- the upper portion of the bent support extends

parallel to the cutting edge between two lateral edges, and each side portion of the frame including two lateral guide surfaces respectively facing the lateral edges of the upper portion of the bent support ;

5 - the blade extends parallel to the guard and the cap between two lateral ends, the lateral edge of the upper portion of the bent support having a rounded protrusion which protrudes laterally from the corresponding side edge of the blade, said rounded protrusion being in sliding
10 engagement with the corresponding lateral guide surface (it should be noted that this feature could be used independently of the above dispositions);

 - the bent support is a cut out and bent sheet metal part including lateral wings which constitute said
15 rounded protrusions, said lateral wings having rounded angles;

 - each slot of the frame is defined between a front guide surface and a back guide surface belonging to the corresponding side portion of the frame, said front
20 guide surface being closer to the guard and said back guide surface being closer to said cap, and said front and back guide surfaces being laterally offset with regard to one another parallel to the cutting edge of the blade, each side portion of the frame further includes a lower stop
25 portion which is near the front guide surface and which is disposed under the upper portion of the bent support to limit sliding of the blade and bent support away from said rest position, the blade unit includes several parallel blades and each side portion of the frame includes at least
30 two slots separated by a partition including:

. the front guide surface, the lower stop portion and the lateral guide surface of one of the slots,

. and the back guide surface of the other slot.

Besides, another object of the present invention is
35 a safety razor including a handle and a razor blade unit as

defined above, mounted on the handle.

BRIEF DESCRIPTION OF THE DRAWINGS

Other features and advantages of the invention appear from the following detailed description of one of its embodiments, given by way of non-limiting example, and with reference to the accompanying drawings.

In the drawings:

- figure 1 is a perspective view of a safety razor according to one embodiment of the invention,
- 10 - figure 2 is an exploded perspective view of the blade unit of the safety razor of figure 1,
- figure 3 is a cross section of the blade unit of figure 2, along line III-III of figure 2,
- figure 4 is a detail cross section of one of the blade members of the blade unit of figures 2 and 3,
- 15 - figures 5 and 6 are respectively a top view and a rear view of the blade member of figure 4,
- figure 7 is a perspective view of one end of the blade member of figures 4-6,
- 20 - figure 8 is a perspective view of the blade support belonging to the blade member of figures 4-7,
- figure 9 is a detail plan view of one end of the blade support of figure 8, before bending thereof,
- figures 10 and 11 are respectively perspective views from below and from the top of a platform member belonging to the blade unit of figures 2 and 3,
- 25 - figure 12 is a detail cross section of the guard of the platform member of figures 10 and 11,
- figure 13 is a detail plan view of the platform member of figures 10 and 11, further showing one of the blade members mounted therein,
- 30 - figures 14 and 15 are respectively cross sections along lines XIV-XIV and XV-XV of figure 13, showing the platform member without any blade member,
- 35 - figure 16 is a cross section of the complete

blade unit, in perspective, the cross section being taken along line XVI- XVI of figure 11,

- figure 17 is an enlarged view of detail XVII of figure 16, without the cover,

5 - figure 18 is a cross section of the complete blade unit, taken along line XVIII-XVIII of figure 11,

- and figure 19 is an enlarged view of detail XIX of figure 19.

MORE DETAILED DESCRIPTION

10 In the figures, the same references denote identical or similar elements.

Figure 1 shows a safety razor 1 (also called wet shaver), i.e. a shaver the blades of which are not driven by a motor relative to the blade unit.

15 The shaver 1 includes a handle 2 extending in a longitudinal direction L between a proximal portion 3 and a distal portion 4 bearing a blade unit 5 or shaving head. The longitudinal direction L may be curved or include one or several straight portions.

20 The blade unit 5 includes an upper face 6 equipped with one or several blades and a lower face 7 which is connected to the distal portion 4 of the handle 2 by a connection mechanism 8. The connection mechanism 8 may for instance enable the blade unit 5 to pivot relative to a
25 pivot axis X which is substantially perpendicular to the longitudinal direction L. Said connection mechanism may further enable to selectively release the blade unit for the purpose of exchanging blade units. One particular example of connection mechanism usable in the present
30 invention is described in document WO-A-2006/027018.

In the particular example shown in figure 1, the handle 2 may further include an internal vibrating mechanism (not shown), which may be for instance as described in the above mentioned document WO-A-2006/027018
35 and which is controlled by a user actuated switch 9.

Of course, the present invention is neither limited to such vibrating handle, nor to any particular connection mechanism connecting the blade unit 5 to the handle 2.

As shown in figures 2 and 3, the blade unit 5 includes a frame 10 which is made solely of synthetic materials, i.e. plastic materials and elastomeric materials.

More precisely, the frame 10 includes a plastic platform member 11 connected to the handle 2 by the connection mechanism 8 and having:

- a guard 12 extending parallel to pivot axis X,
- a blade receiving section 13 situated rearward of the guard 12 in the direction of shaving,
- a cap portion 14 extending parallel to pivot axis X and situated rearward of the blade receiving section 13 in the direction of shaving,
- and two side portions 15 joining the longitudinal ends of the guard 12 and of the cap portion 14 together.

The upper surface of the rear portion 37 of the guard 12 and the upper surface of the front portion 38 of the cap portion 14 come into contact with the user's skin during shaving and define a reference plane P which is tangent to said upper surfaces of said rear portion 37 and front portion 38.

In the example shown in the figures, the guard 12 is covered by an elastomeric layer 16 forming a plurality of fins 17 extending parallel to pivot axis X. As shown in more details in figure 12, the elastomeric layer 16 may include for instance four fins 17 in the direct. The second fin 17 (in the direction of the shaving) may for instance have its apex situated at a height h_1 around 0,34 mm above the apex of the first fin 17 (the height h_1 being measured perpendicular to the reference plane P), whereas the apex of the third fin 17 is situated at a height h_2 for instance

around 0,20 mm above the apex of the second fin 17, the apex of the fourth fin 17 being situated at a height h_3 around 0,12 mm above the apex of the third fin 17 and the rear portion 37 of the guard, being made as a single piece of plastic material with platform 11 being at a height h_4 around 0,6 mm above the of plastic material of the fourth fin. Further, in the particular example shown in the drawings, the distance e_1 between the apices of the first and second fins 17 is around 0,52 mm, the distance e_2 between the apices of the second and third fins is around 0,48 mm, the distance e_3 between the apices of the third and fourth fins is around 0,45 mm, the distance e_4 between the apex of the fourth fin and the rear portion 37 of the guard is around 0,43 mm, and the width e_5 of the rear portion 37 of the guard is around 0,5 mm (these distances e_1 - e_5 are measured parallel to the reference plane P and perpendicular to pivot axis X).

Further, in this particular example, the underside of the platform member 11 includes two shell bearings 18 which belong to the connection mechanism 8 and which may be for example as described in the above-mentioned document WO-A-2006/027018 (see figures 2, 3 and 10).

The frame 10 further includes a plastic cover 19 which exhibits a general U shape, with a cap portion 20 partially covering the cap portion 14 of the platform and two side members 21 covering the two side members 15 of the platform.

The cap portion 20 of the cover forms, with the cap portion 14 of the platform, a cap 22 which comes into contact with the skin of the user during shaving. The cap portion 20 of the cover 19 may include a lubricating strip 23 which is oriented upward and comes into contact with the skin of the user during shaving. This lubricating strip may be formed for instance by co-injection with the rest of the cover.

Besides, the side members 21 of the cover form, together with the side members 15 of the platform, two side portions of the frame, joining the guard 12 to the cap 22.

The cover 19 may be fixed to the platform 11 by
5 any known means, for instance by ultrasound welding or by laser welding, for instance as described in document WO-A-2005/108024.

Besides, at least one blade member 24 is movably mounted in the blade receiving section 13 of the platform.
10 The blade receiving section 13 may include several blade members 24, for instance four blade members as in the example shown in the drawings.

As shown in figure 3-7, each blade member 24 includes a blade 25 which is formed by a flat steel strip
15 with a cutting edge 26 oriented forward in the direction of shaving. Each blade 25 has an upper face 27 oriented towards the skin to be shaved and a lower face 28 oriented toward the handle 2. The upper and lower faces 27, 28 of the blade include respectively two parallel main surfaces
20 29,30 and two tapered facets 31,32 which taper towards the cutting edge 26.

As shown in figures 5-7, each blade 25 extends longitudinally, parallel to pivot axis X, between two lateral ends 33.

25 Each blade 25 is borne by a bent support 34 which is visible in more details in figures 7-9. The bent support 34 is a sheet metal part made out of steel with a bent profile including:

- 30 - a substantially flat lower portion 35 (i.e. substantially perpendicular to reference plane P),
- and a substantially flat upper portion 39 which extends parallel to the blade 25.

The blade 25 is fixed on the upper portion 39 of the bent support by any known means, for instance by laser
35 spot welding.

The angle α of the upper portion 39 and of the

blade 25 which regard to reference plane P may be around 22°.

As shown in figures 5-9, the lower portion 35 of the bent support 34 extends longitudinally, parallel to pivot axis X, between two lateral portions 40. Each lateral portion 40 includes a side edge 41.

Besides, the upper portion 39 of the bent support extends longitudinally between two lateral edges each including a rounded protrusion 42 which is constituted by a lateral wing with rounded angles protruding laterally from the upper portion 39 and from a corresponding lateral end 33 of the blade.

Further, a rounded indent 43 is cut out from the sheet metal forming the blade support, said indent separating the rounded protrusion 42 from the lateral edge 41 of the lower portion.

The side edges 41 of the lower portion of the bent support protrude laterally from the lateral ends 33 of the blade and from the rounded protrusions 42.

As shown in figure 9, the bent support may be made from a flat sheet metal part which is then bent before welding of the blade 25 on the upper portion 39 thereof.

As shown in figures 2 and 3, each blade member 34 is borne by two elastic fingers 44 which are molded as a single piece with platform 11 and which extend towards each other and upwardly from both side members 15 of the platform.

Besides, as shown in figures 2, 11 and 13, the end portions 40 of the bent supports are slidably mounted in vertical slots 45 (i.e. slots which are substantially perpendicular to the reference plane P) provided in the inner face of each side member 15 of the platform.

Each vertical slot 45 of the platform is defined between a front guide surface 47 and a back guide surface 48 belonging to the corresponding side member 15 of the platform. The front and back guide surfaces are laterally offset with regard to one another parallel to axis X. The

front guide surface 47 may be latterly offset from the blade 25, said front guide surface 47 been closer to the side member 15 than the back guide surface 48.

Besides each front guide surface 47, the side member 15 of the platform includes a lower stop portion 50 which forms an oriented flat surface situated beneath the upper portion 39 of the blade support 34 and which extends parallel to said upper portion 39. Each lower stop portion 50 is designed to limit the downward sliding of the corresponding blade member 34 under forces encountered during shaving.

Further, for each blade member 24, each side member 15 of the platform includes two lateral guide surfaces 49 respectively facing the rounded protrusions 42 of the corresponding blade member, said protrusions 42 being in sliding engagements with the corresponding lateral guide surfaces 49. The lateral guide surfaces 49 may be sloping toward each other, for instance with a small sloping angle comprised between 2 and 5 degrees with regard to a direction perpendicular to reference plane P.

In the example shown in the drawings, the vertical slots 45 are separated from each other by partitions 50a which are molded as a single piece with platform 11 and which include each:

- the front guide surface 47, the lateral guide surface 49 and the lower stop portion 50 of the slot situated rear of the partition 50a,
- and the back guide surface 48 of the slot situated forward of the partition 50a.

As shown on figures 16-19, the blade members 24 are elastically biased by the elastical arms 44 toward a rest position. In this rest position, the upper faces 27 of the blades, at each lateral end of the blades, bear against corresponding upper stop portions 52 which are provided on the underside 51 of each side member 21 of the cover, said side member 21 covering the slots 45.

More precisely, in the example shown in the

drawings, the upper facets 31 of each blade bear against the upper stop portions 52, and said upper stop portions 52 are parallel to said upper facets 31.

Thanks to this disposition, the cutting edges 26
5 of the blades 25 do not cut the plastic material of the side members 21, and the blades 25 are not damaged by said side portions 21 of the cover.

Therefore, the rest position of the blade
members 24 is well defined, therefore enabling a high
10 shaving precision.

In particular, the maximum exposure EXP of each
blade 25, i.e. the distance separating the cutting edge 26
of the blade from the reference plane P (see figure 4),
measured perpendicularly to reference plane P, is precisely
15 defined. In the example shown in the drawings, this maximum
exposure EXP may be around + 0,02 mm.

Besides, as shown in figure 3, when the blades
24 are in the rest position, the distance SP1 between the
rear portion 37 of the guard and the cutting edge 26 of the
20 first blade in the direction of shaving may be around 0,66
mm, whereas the spans SP2, SP3, SP4 between the cutting
edges of the four blades may be around 1,48 mm (these
distances SP1-SP4 are measured parallel to the reference
plane P and perpendicularly to pivot axis X).

WE CLAIM:

1. Razor blade unit including a frame and at least one blade movably mounted in said frame, said blade including an upper face, a lower face and a cutting edge, said frame including at least one upper stop portion and said blade being elastically biased toward said upper stop portion, where said blade is in a rest position,

wherein the upper face of said blade bears against the upper stop portion when the blade is in the rest position, said upper face being substantially parallel to the upper stop portion, wherein the blade is slidingly mounted in two slots which are provided respectively in two side portions of the frame.

2. Razor blade unit according to claim 1, wherein the blade is movable under forces encountered during shaving and the rest position is a position of maximum exposure of the blade.

3. Razor blade unit according to any one of claims 1 and claim 2, wherein the frame includes at least one elastic finger elastically biasing the blade toward the rest position.

4. Razor blade unit according any one of claims 1 to 3, wherein the frame is made of synthetic material.

5. Razor blade unit according any one of claims 1 to 4, wherein the frame is made of a material other than metal .

6. Razor blade unit according to any one of claims 1 to 5, wherein the upper and lower faces of the blade

include respectively two parallel main surfaces and two tapered facets which taper toward the cutting edge, the tapered facet of the upper face bearing against the upper stop portion in the rest position and said tapered facet of the upper face being substantially parallel to the upper stop portion.

7. Razor blade unit according to any one of claims 1 to 6, wherein the frame includes a guard, a cap and two side portions joining the guard to the cap, the blade extending parallel to the guard and the cap between two lateral ends which are respectively near said two side portions, said side portions including two upper stop portions against which the two lateral ends of the blade bear respectively in the rest position, the upper face of the blade being substantially parallel to said two upper stop portions.

8. Razor blade unit according to claim 7, including several parallel blades, wherein the side portions include two upper stop portions for each blade, against which the two lateral ends of each blade bear respectively in the rest position, the upper face of each blade being substantially parallel to the corresponding upper stop portions.

9. Razor blade unit according to claim 1, wherein the blade is borne by a bent support having a lower portion extending in a plane parallel to the slots and an upper portion extending in a plane parallel to the blade, the lower portion extending parallel to the cutting edge between two lateral portions which are slidably mounted in the slots.

10. Razor blade unit according to claim 9, wherein each slot of the frame is defined between a front guide surface and a back guide surface belonging to the corresponding side portion of the frame, said front guide surface being closer to the guard and said back guide surface being closer to said cap, and said front and back guide surfaces being laterally offset with regard to one another parallel to the cutting edge of the blade.

11. Razor blade unit according to claim 10, wherein each lateral portion of the lower portion of the blade support has a side edge and the slot in which said side portion is slidably mounted has its front guide surface closer to said side edge (and its back guide surface further away from the side edge).

12. Razor blade unit according to any one of claims 9 to 11, wherein each side portion of the frame further includes a lower stop portion which is near the front guide surface and which is disposed under the upper portion of the bent support to limit sliding of the blade and cent support away from said rest position .

13. Razor blade unit according to claim 12, wherein the lower stop portion is substantially parallel to the upper portion of the bent support.

14. Razor blade unit according to any one of claims 12 and 13, wherein each lateral portion of the lower portion of the blade support has a side edge and said lateral portions of the lower portion of the bent support are protruding laterally from the upper portion and from the blade, each lower stop portion being offset laterally

from the front guide surface, away from the corresponding side edge of the lower portion of the blade support.

15. Razor blade unit according to any one of claims 9 to 14, wherein the upper portion of the bent support extends parallel to the cutting edge between two lateral edges, and each side portion of the frame including two lateral guide surfaces respectively facing the lateral edges of the upper portion of the bent support.

16. Razor blade unit according to claim 15, wherein the blade extends parallel to the guard and the cap between two lateral ends, the lateral edge of the upper portion of the bent support having a rounded protrusion which protrudes laterally from the corresponding lateral end of the blade, said rounded protrusion being in sliding engagement with the corresponding lateral guide surface.

17. Razor blade unit according to claim 16, wherein the bent support is a cut out and bent sheet metal part including lateral wings which constitute said rounded protrusions, said lateral wings having rounded angles.

18. Razor blade unit according to any one of claims 15 to 17, wherein each slot of the frame is defined between a front guide surface and a back guide surface belonging to the corresponding side portion of the frame, said front guide surface being closer to the guard and said back guide surface being closer to said cap, and said front and back guide surfaces being laterally offset with regard to one another parallel to the cutting edge of the blade,

wherein each side portion of the frame further includes a lower stop portion which is near the front guide surface and which is disposed under the upper portion of the bent support to limit sliding of the blade and bent support away from said rest position,

and wherein the blade unit includes several parallel blades and each side portion of the frame includes at least two slots separated by a partition including:

- the front guide surface, the lower stop portion and the lateral guide surface of one of the slots,
- and the back guide surface of the other slot.

19. Safety razor including a handle and a razor blade unit as claimed in any one of claims 1 to 18, mounted on the handle.

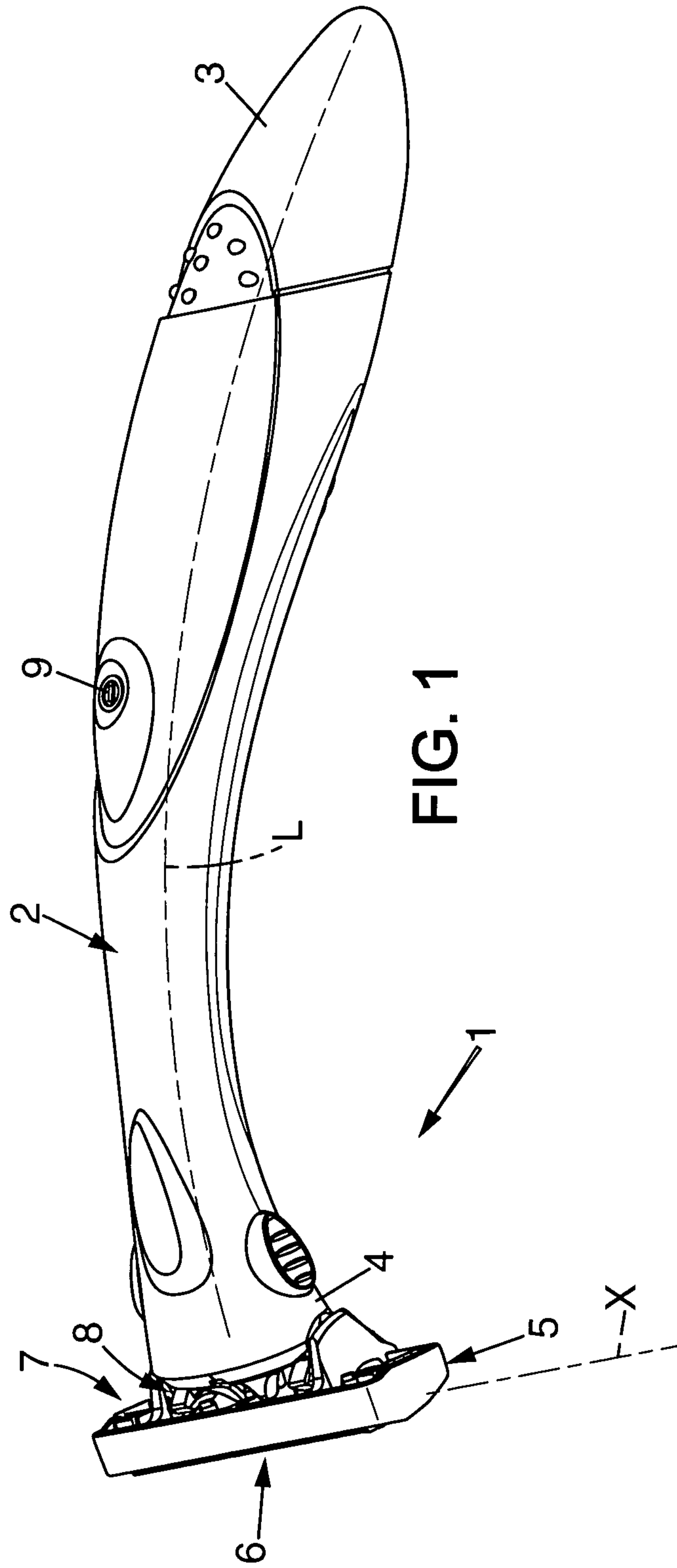

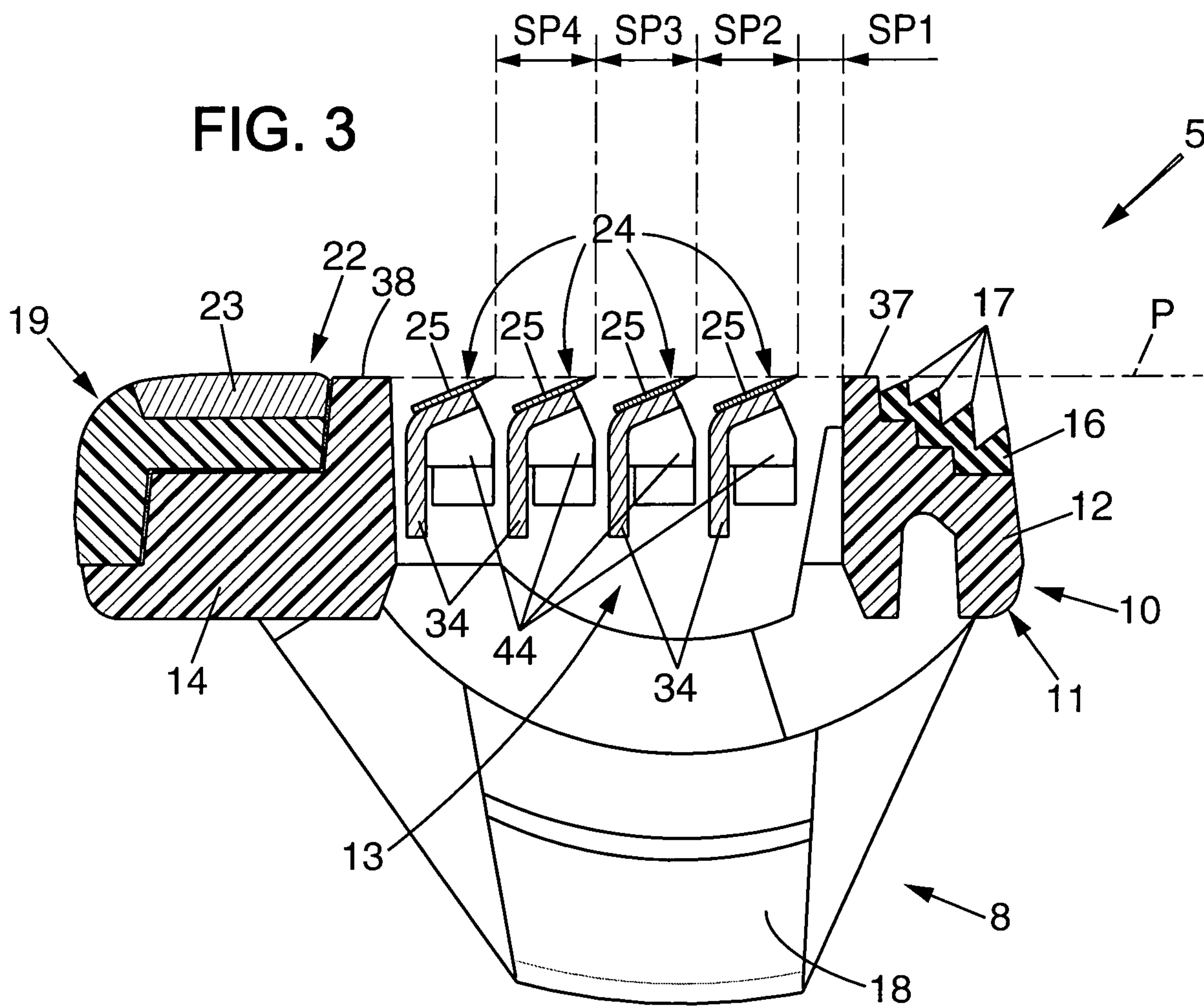

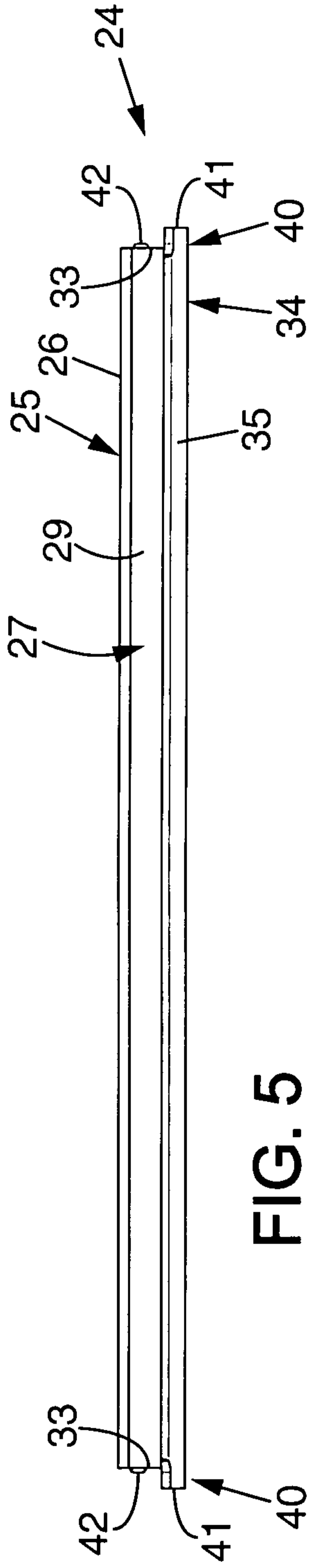

FIG. 5

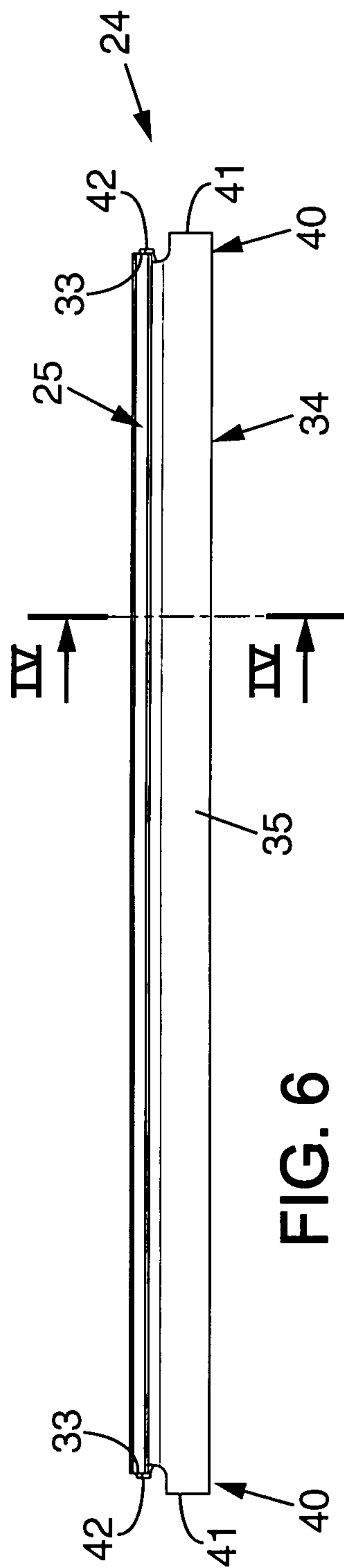

FIG. 6

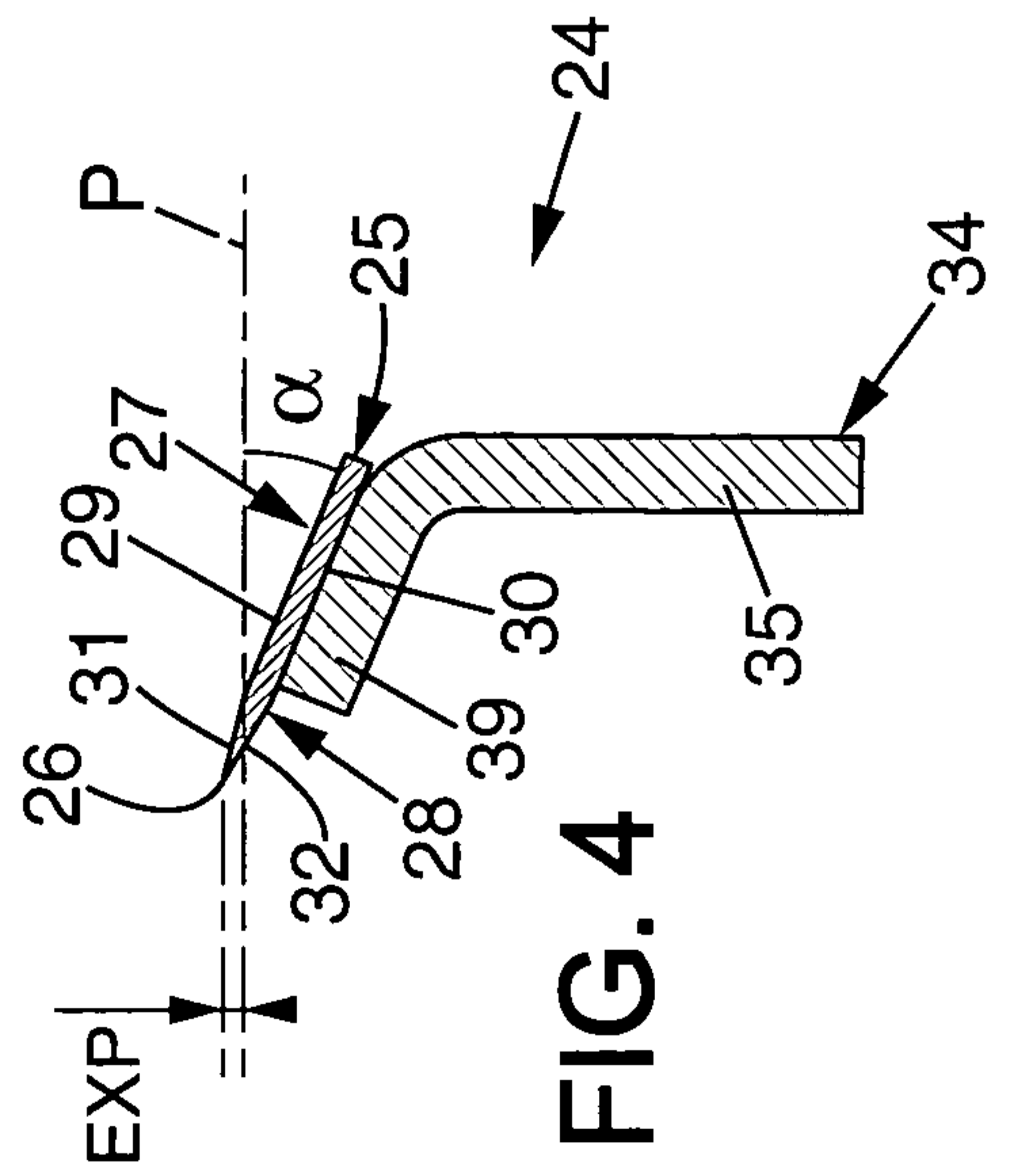

FIG. 4

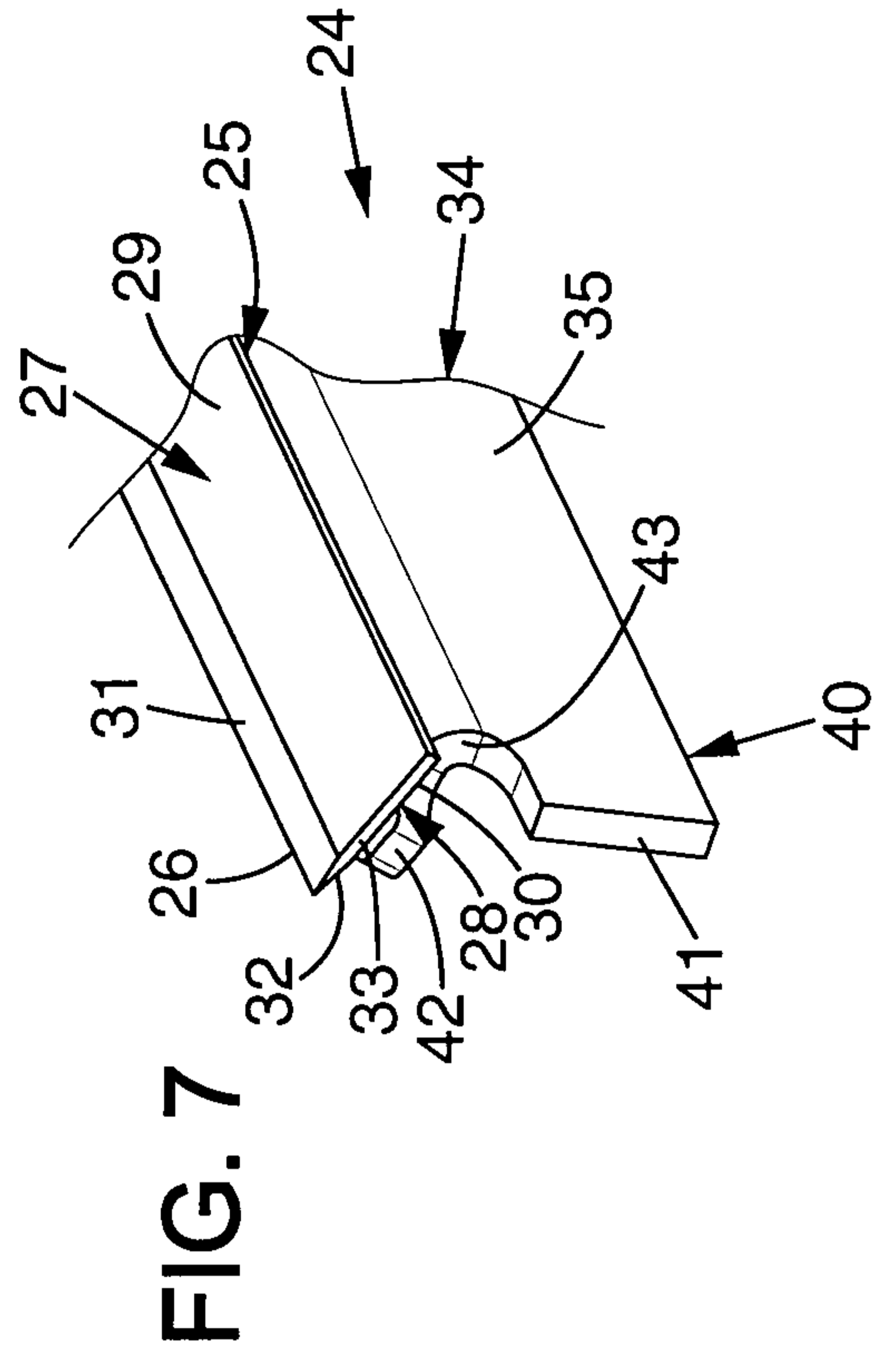
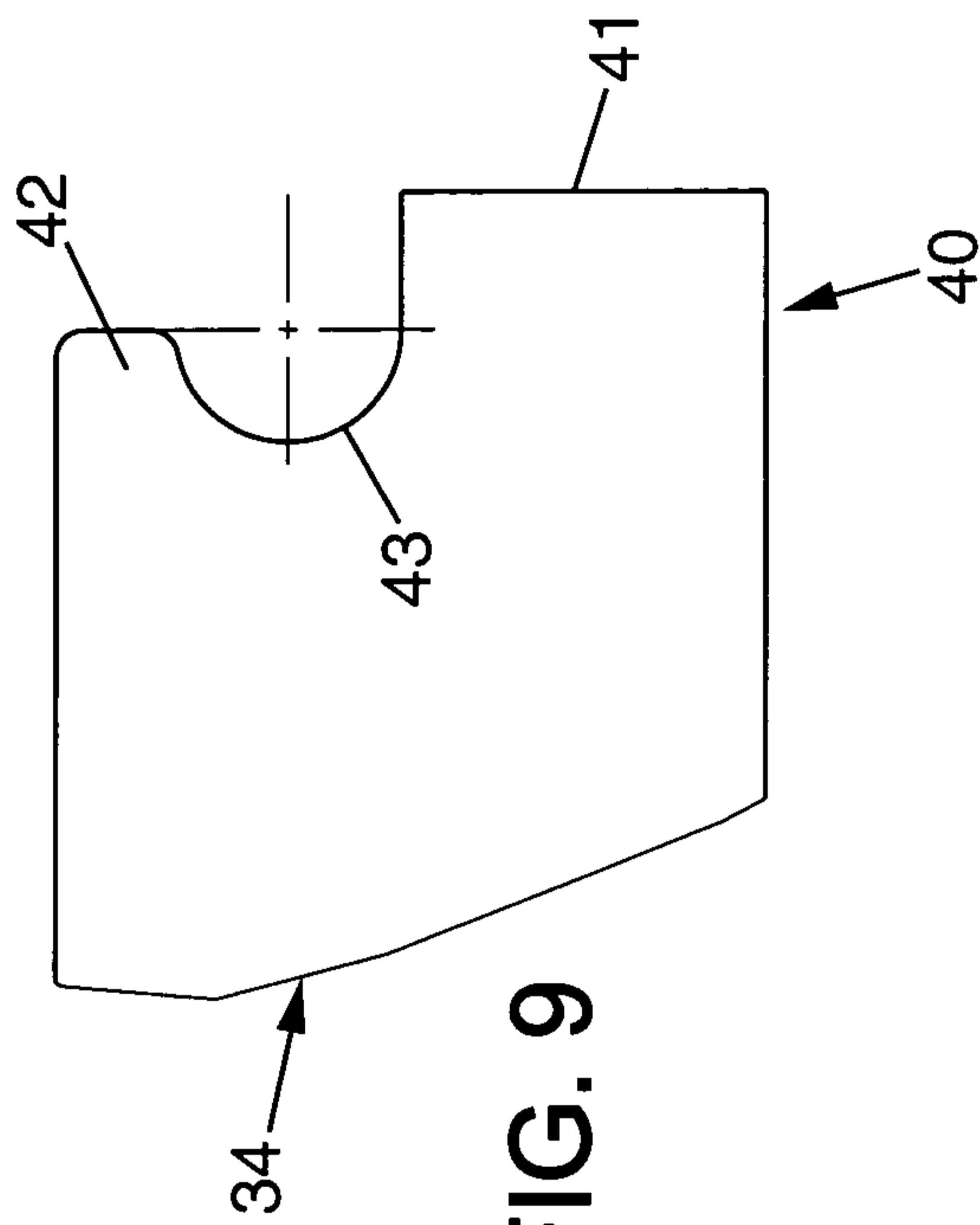
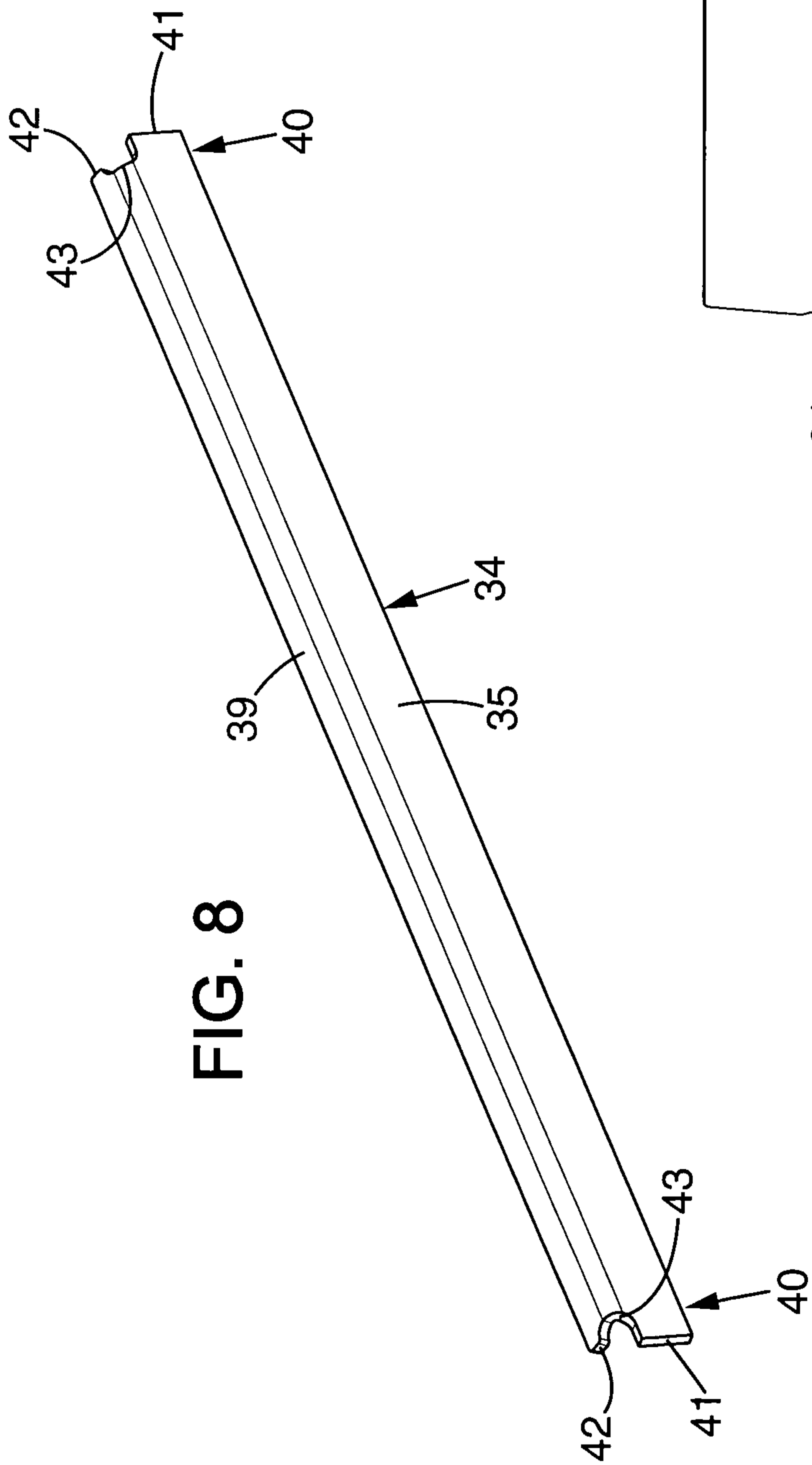
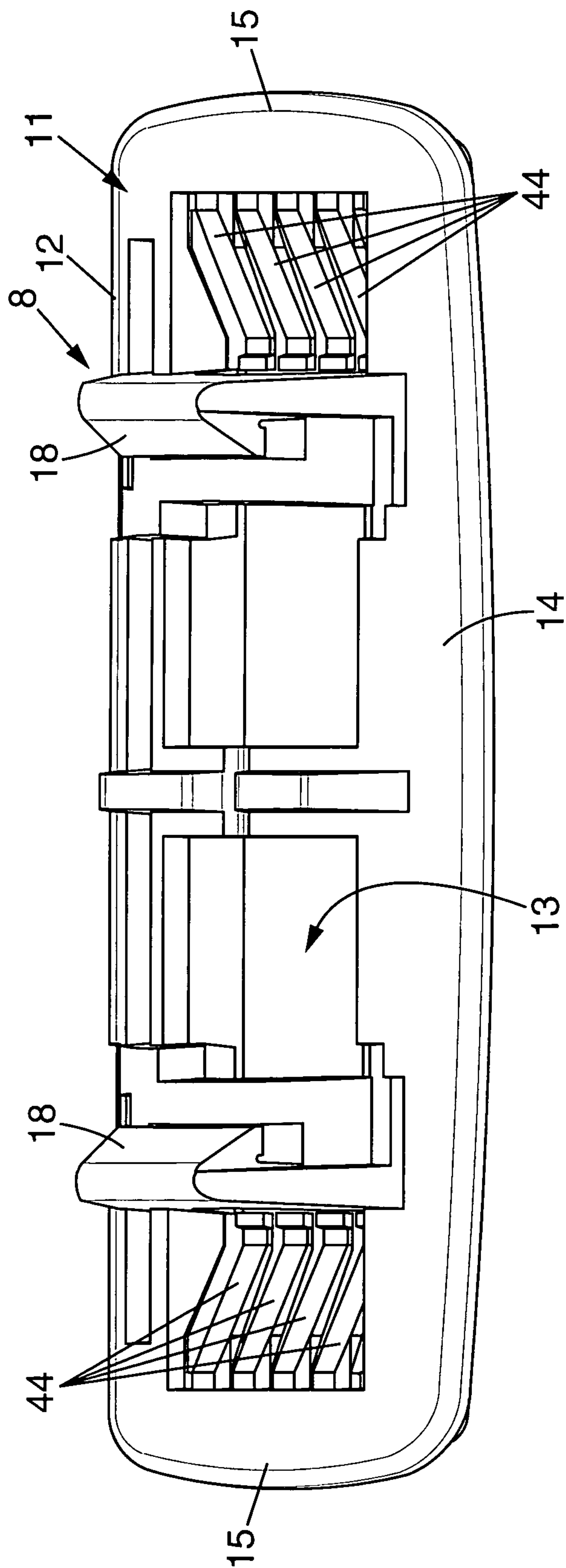

FIG. 7



6/11

FIG. 10



7/11

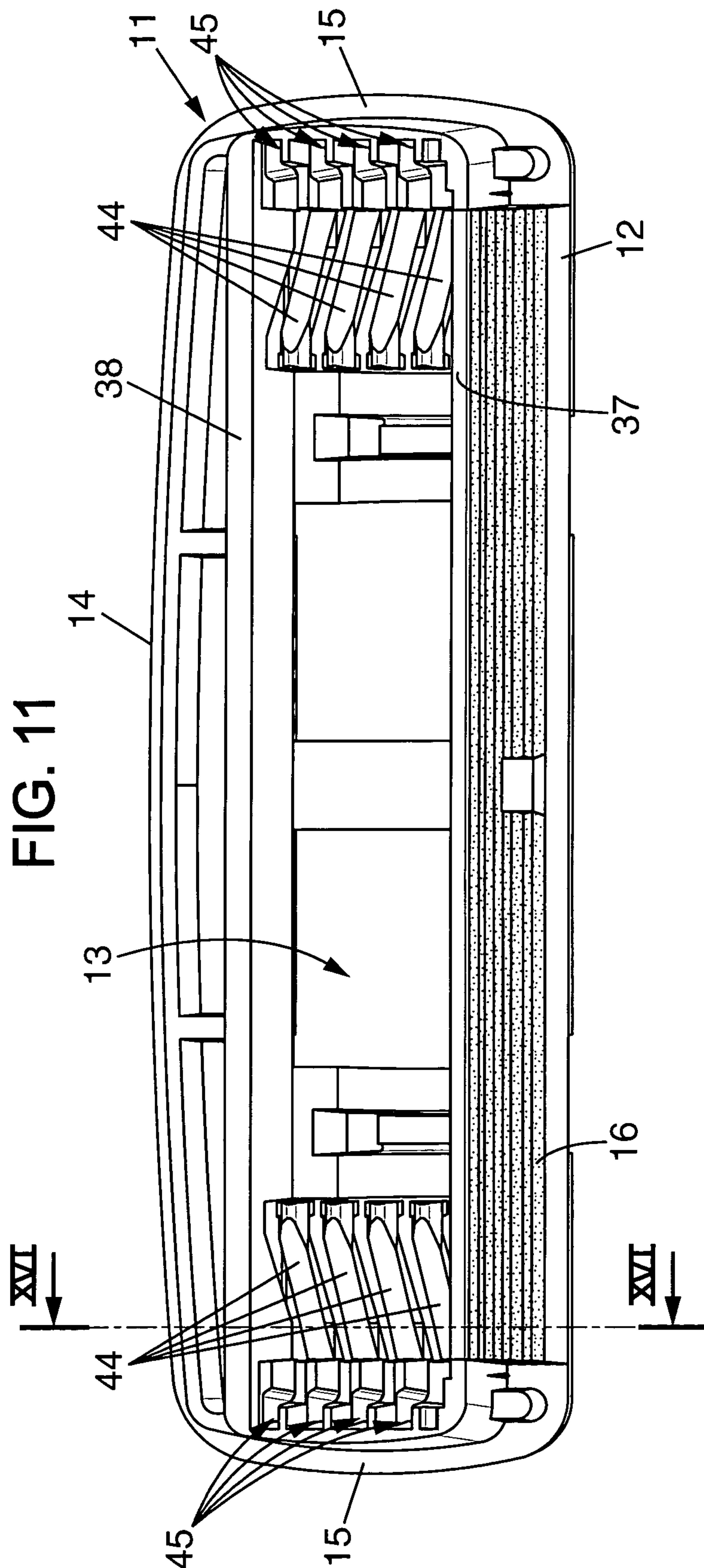

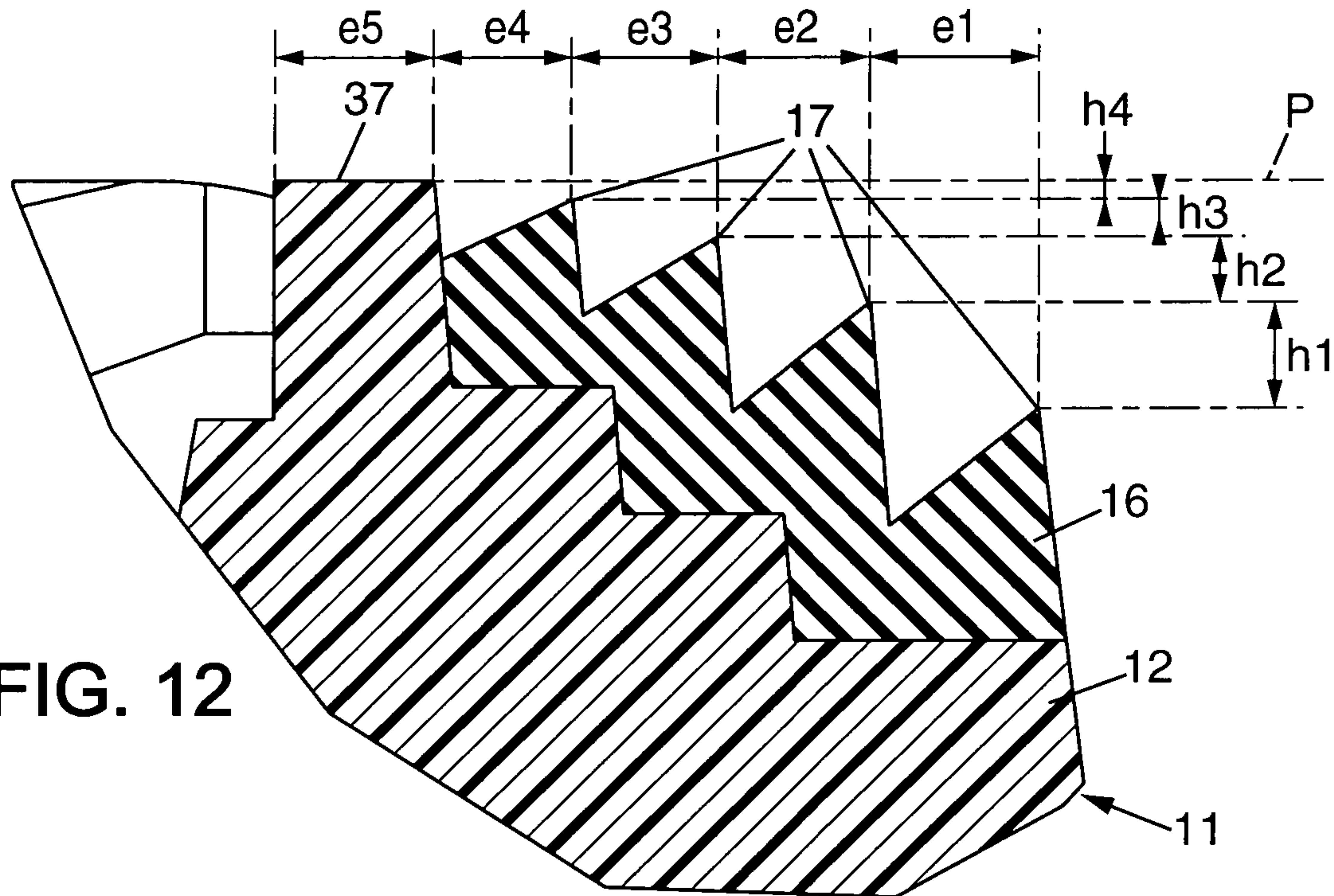

FIG. 12

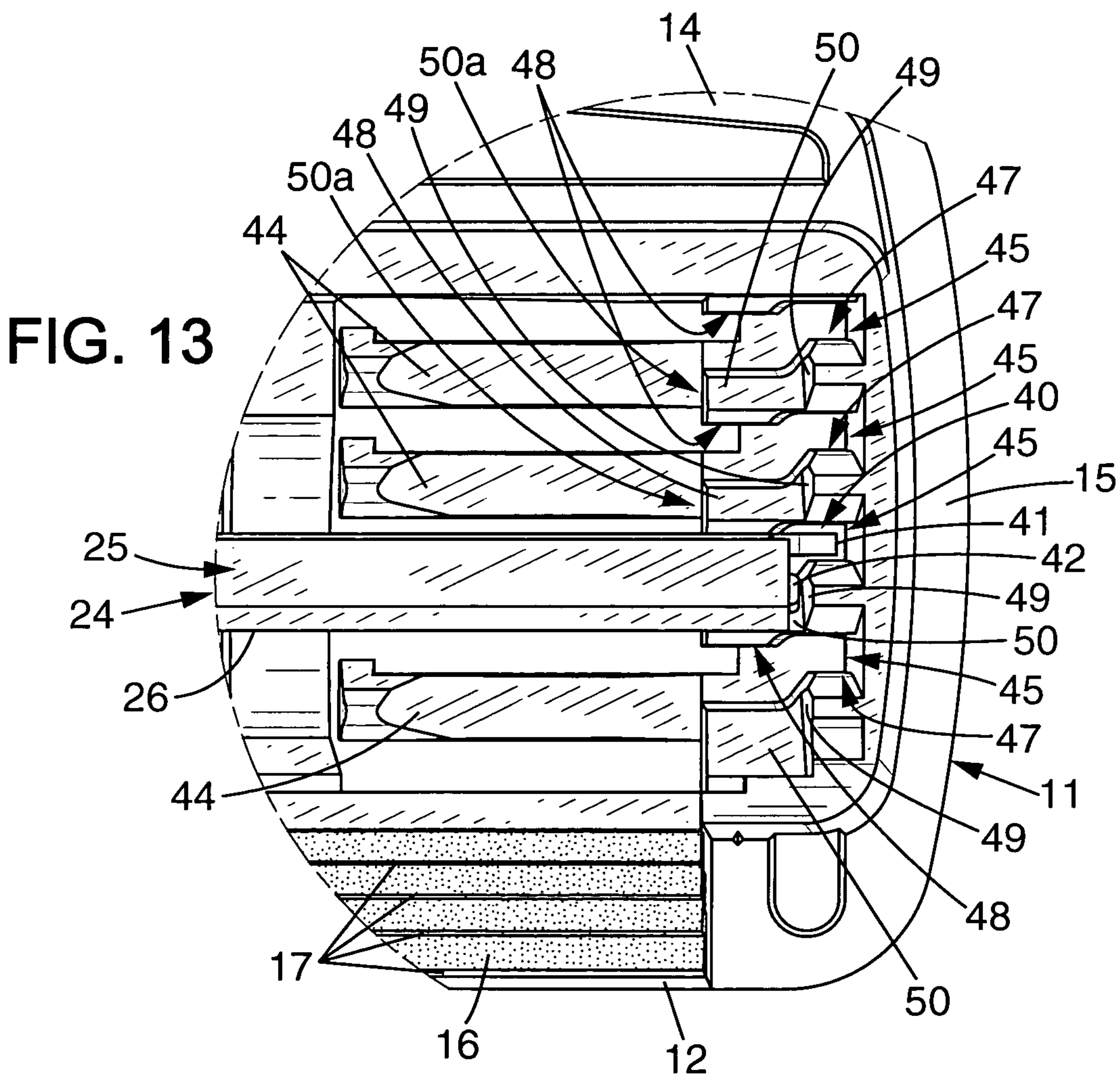

FIG. 13

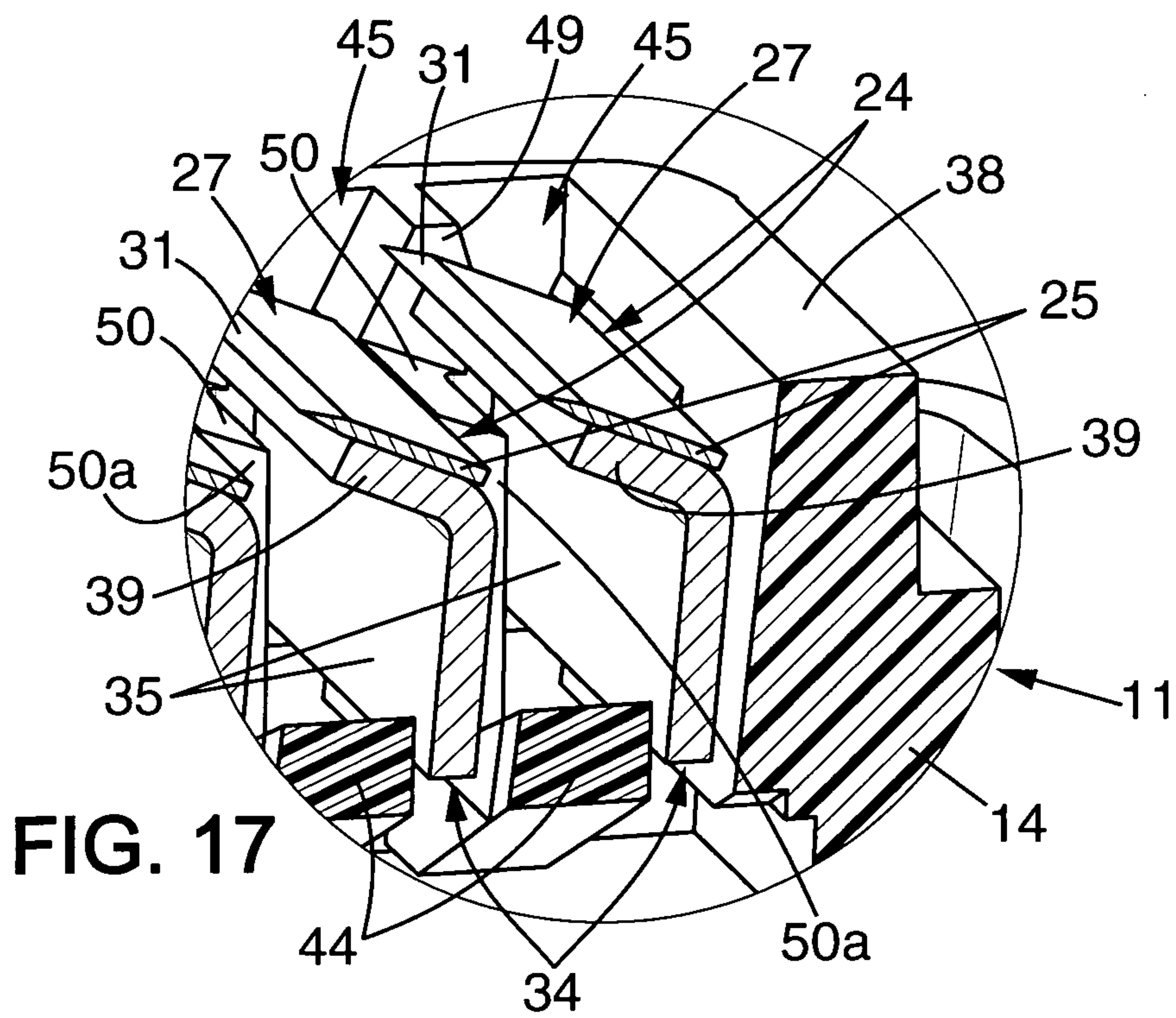
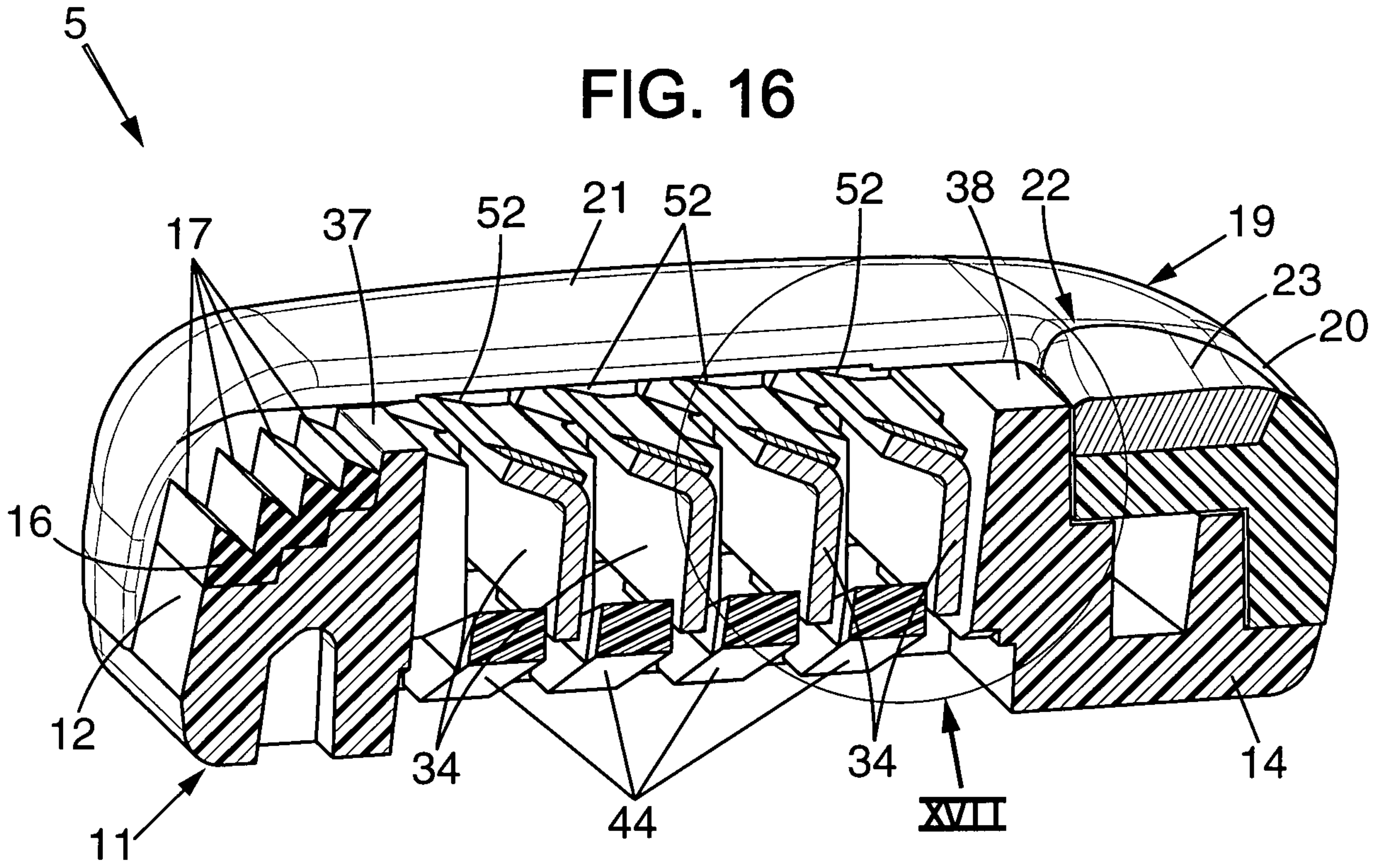

FIG. 18

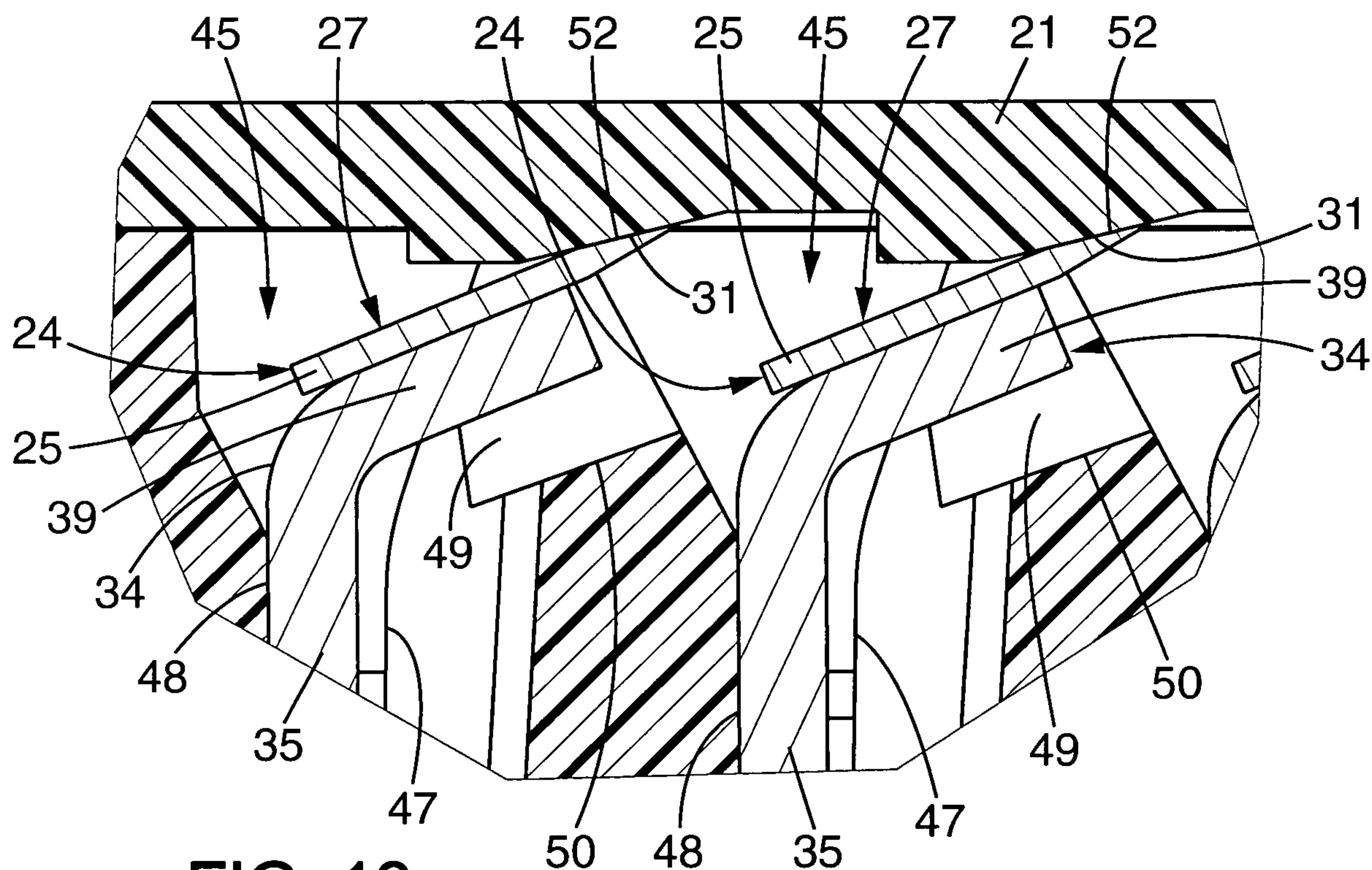
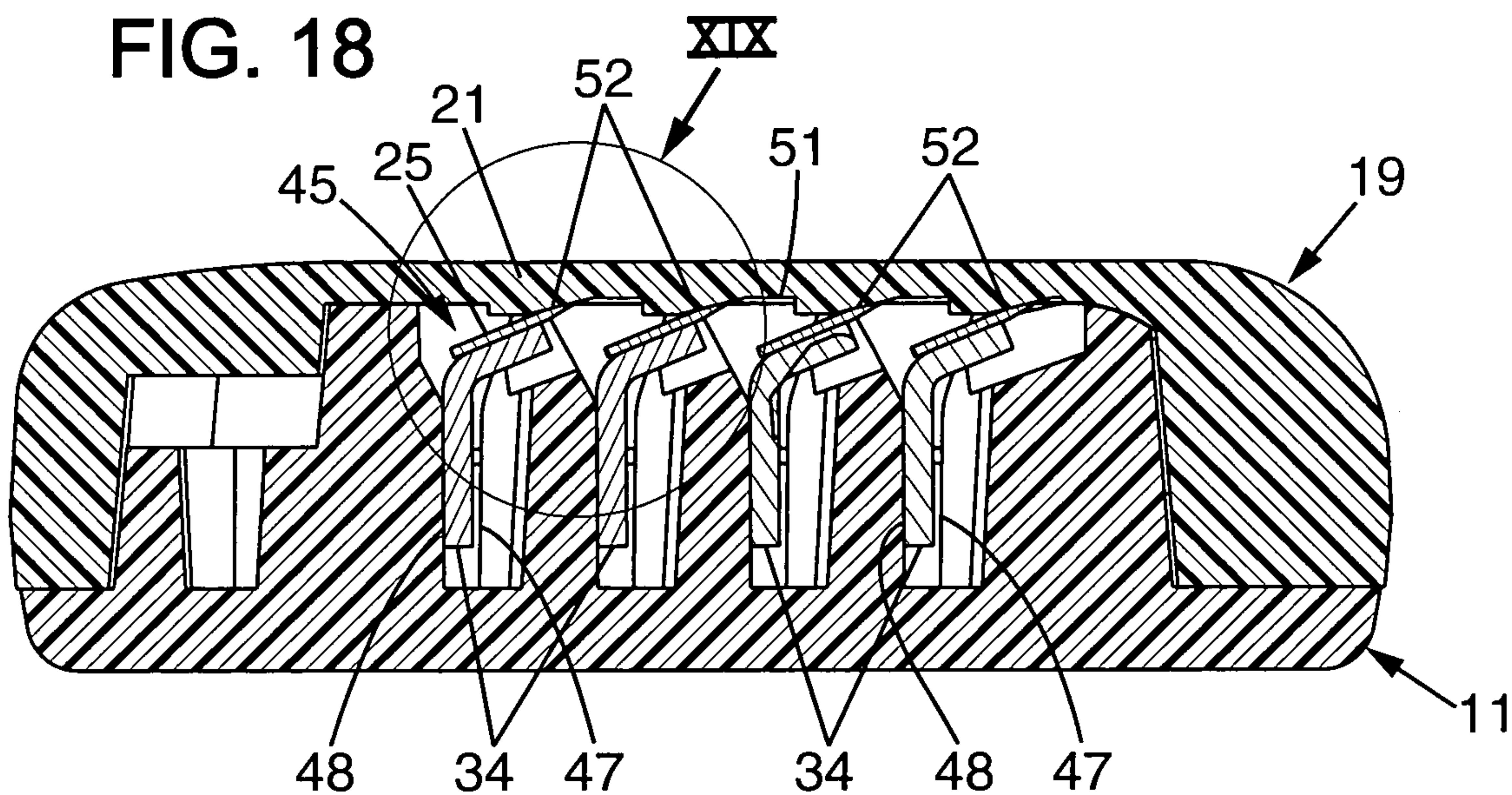

FIG. 19

