

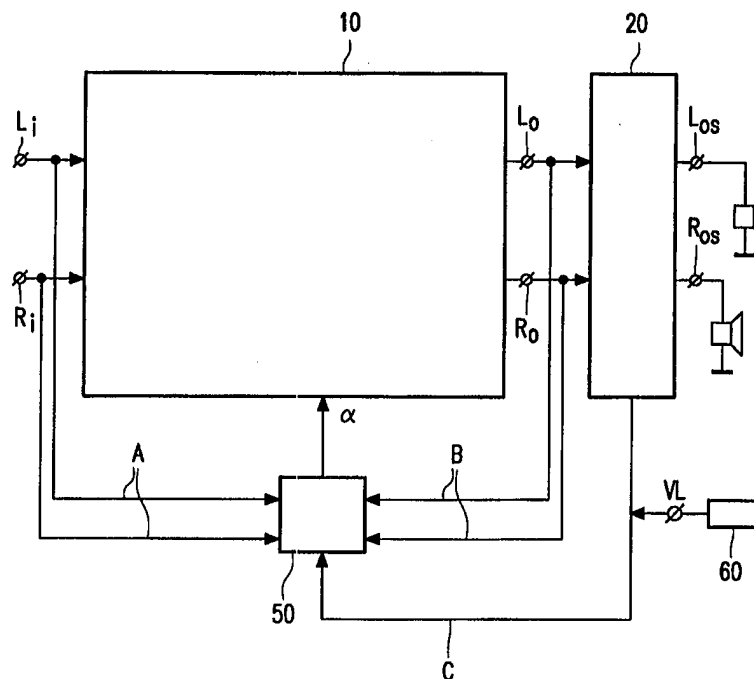

INTERNATIONAL APPLICATION PUBLISHED UNDER THE PATENT COOPERATION TREATY (PCT)

(51) International Patent Classification ⁶ : H04S 1/00	A1	(11) International Publication Number: WO 98/21915 (43) International Publication Date: 22 May 1998 (22.05.98)
<p>(21) International Application Number: PCT/IB97/01203</p> <p>(22) International Filing Date: 3 October 1997 (03.10.97)</p> <p>(30) Priority Data: 96203131.6 8 November 1996 (08.11.96) EP (34) Countries for which the regional or international application was filed: NL et al.</p> <p>(71) Applicant: PHILIPS ELECTRONICS N.V. [NL/NL]; Groenewoudseweg 1, NL-5621 BA Eindhoven (NL).</p> <p>(71) Applicant (for SE only): PHILIPS NORDEN AB [SE/SE]; Kottbygatan 7, Kista, S-164 85 Stockholm (SE).</p> <p>(72) Inventors: AARTS, Ronaldus, Maria; Prof. Holstlaan 6, NL-5656 AA Eindhoven (NL). BEIJER, Paul, Arnold, Christiaan; Prof. Holstlaan 6, NL-5656 AA Eindhoven (NL). TOONEN DEKKERS, Robertus, Theodorus, Johannes; Prof. Holstlaan 6, NL-5656 AA Eindhoven (NL).</p> <p>(74) Agent: SCHOONHEIJM, Harry, B.; Internationaal Octrooibureau B.V., P.O. Box 220, NL-5600 AE Eindhoven (NL).</p>		<p>(81) Designated States: CN, JP, KR, European patent (AT, BE, CH, DE, DK, ES, FI, FR, GB, GR, IE, IT, LU, MC, NL, PT, SE).</p> <p>Published With international search report.</p>

(54) Title: AN ARRANGEMENT, A SYSTEM, A CIRCUIT AND A METHOD FOR ENHANCING A STEREO IMAGE



(57) Abstract

The invention provides a stereophonic audio signal processing arrangement for variably enhancing a stereo image, wherein the stereo image enhancement is reduced at high levels so as to reduce distortion. The arrangement is used in a stereophonic audio reproduction system for enhancing the stereo image, which system may be part of an audio-visual reproduction system. The invention also relates to a stereo enhancement circuit and to a method for enhancing a stereo image of a stereo input signal.

FOR THE PURPOSES OF INFORMATION ONLY

Codes used to identify States party to the PCT on the front pages of pamphlets publishing international applications under the PCT.

AL	Albania	ES	Spain	LS	Lesotho	SI	Slovenia
AM	Armenia	FI	Finland	LT	Lithuania	SK	Slovakia
AT	Austria	FR	France	LU	Luxembourg	SN	Senegal
AU	Australia	GA	Gabon	LV	Latvia	SZ	Swaziland
AZ	Azerbaijan	GB	United Kingdom	MC	Monaco	TD	Chad
BA	Bosnia and Herzegovina	GE	Georgia	MD	Republic of Moldova	TG	Togo
BB	Barbados	GH	Ghana	MG	Madagascar	TJ	Tajikistan
BE	Belgium	GN	Guinea	MK	The former Yugoslav Republic of Macedonia	TM	Turkmenistan
BF	Burkina Faso	GR	Greece	ML	Mali	TR	Turkey
BG	Bulgaria	HU	Hungary	MN	Mongolia	TT	Trinidad and Tobago
BJ	Benin	IE	Ireland	MR	Mauritania	UA	Ukraine
BR	Brazil	IL	Israel	MW	Malawi	UG	Uganda
BY	Belarus	IS	Iceland	MX	Mexico	US	United States of America
CA	Canada	IT	Italy	NE	Niger	UZ	Uzbekistan
CF	Central African Republic	JP	Japan	NL	Netherlands	VN	Viet Nam
CG	Congo	KE	Kenya	NO	Norway	YU	Yugoslavia
CH	Switzerland	KG	Kyrgyzstan	NZ	New Zealand	ZW	Zimbabwe
CI	Côte d'Ivoire	KP	Democratic People's Republic of Korea	PL	Poland		
CM	Cameroon	KR	Republic of Korea	PT	Portugal		
CN	China	KZ	Kazakstan	RO	Romania		
CU	Cuba	LC	Saint Lucia	RU	Russian Federation		
CZ	Czech Republic	LI	Liechtenstein	SD	Sudan		
DE	Germany	LK	Sri Lanka	SE	Sweden		
DK	Denmark	LR	Liberia	SG	Singapore		
EE	Estonia						

An arrangement, a system, a circuit and a method for enhancing a stereo image.

The invention relates to a stereophonic audio signal processing arrangement comprising:

- signal processing means, including a stereo enhancement circuit for processing a stereo input signal,
- 5 - signal amplifying means for amplifying a stereo output signal supplied by the signal processing means,

said stereo enhancement circuit comprising:

- first means having a first and a second input for receiving a left channel and a right channel signal of the stereo input signal and a first and a second output for
10 supplying a left channel and a right channel signal of a stereo signal having an enhanced stereo image,
- second means for controllably combining the stereo input signal and the stereo output signal of the first means for varying the stereo image enhancement.

The invention further relates to a stereophonic audio reproduction system
15 including such a stereophonic audio signal processing arrangement, left channel and right channel loudspeakers for reproducing the amplified stereo signal supplied by the signal amplifying means.

The invention also relates to an audio-visual reproduction system including
20 such a stereophonic audio reproduction system, a cabinet in which a picture display screen and the left channel and right channel loudspeakers are installed.

The invention relates to a stereo enhancement circuit.

The invention also relates to a method for enhancing a stereo image of a stereo input signal, comprising the steps of:

- generating a stereo output signal having an enhanced stereo image from the
25 stereo input signal,
- controllably combining the stereo input signal and the stereo output signal to provide a processed stereo output signal.

Such an arrangement, such systems and such a circuit are known from the European patent application EP-A 664661. In the known arrangement the enhanced stereo signal can be mixed with the input stereo signal for example in a ratio $(1-\alpha):\alpha$. By varying α between 0 and 1 the amount of stereo image enhancement can be varied from conventional or normal stereo to fully enhanced stereo. A drawback of the known stereo image enhancement is that the amplitude of the enhanced stereo signal can be more than 10 dB larger than the amplitude of the normal, unenhanced, stereo signal, even though the loudness of the resulting acoustical signals is perceived as substantially the same. At high signal levels this larger amplitude of the enhanced stereo signal may give rise to distortion in an amplifier following the arrangement.

An object of the present invention is to provide an arrangement producing less distortion than the known arrangement.

An arrangement according to the invention is characterized in that the stereo enhancement circuit comprises control means coupled to the second means for controlling the combining of the stereo signals so as to reduce the stereo image enhancement at high signal levels.

The invention is based on the recognition that a reduction of the stereo image enhancement of the stereo signal usually results in a reduction of the amplitude of each of the left channel and right channel signals of the enhanced stereo signal. By reducing the stereo image enhancement at high signal levels, distortion can be significantly reduced as now the amplifier will receive signals with a reduced amplitude compared to signals having the full stereo image enhancement.

An embodiment of the invention is characterized in that the arrangement comprise volume level setting means supplying a signal representative of a volume level to the amplifying means for setting the volume level, and to the control means for controlling the combining as a function of the set volume level.

The actual or set volume level of the arrangement can be used as an indication that high signal levels can be expected. By reducing the stereo image enhancement at high volume levels, i.e. as a function of the set volume level, a simple implementation of the control means is achieved without the need for measuring the actual signal levels.

A further embodiment of the invention is characterized in that the control means comprise means for comparing the signal level of the amplified stereo output signal

with a reference level and supplying a control signal to the second means for reducing the stereo image enhancement when the signal level exceeds the reference level.

By measuring the actual output signals of the amplifying means, it is possible to accurately determine if distortion is present e.g. when the signal level exceeds a level above which the amplification becomes non-linear. This level is represented by the threshold.

A further embodiment of the invention is characterized in that the control means comprise means for comparing the signal level of the stereo output signal of the second means with a reference level and supplying a control signal to the second means for reducing the stereo image enhancement when the signal level exceeds the reference level.

10 An alternative to measuring the signal level of the output signals of the amplifying means is to measure the signal level of the output signals of the second means which are to be supplied to the amplifying means. Now the control means do not need to process signals having a large amplitude resulting from the amplification by the amplifying means.

A further embodiment of the invention is characterized in that the reference level is a function of the set volume level.

Headroom is the amount of extra amplification that a signal may undergo before being distorted by the amplifying means. The set volume level gives an indication of how much headroom the amplifier still has. As the volume control is normally located behind the stereo enhancement circuit, the set volume level can serve as the reference level, indicating when the stereo image enhancement should be reduced in order to avoid distortion.

A further embodiment of the invention is characterized in that the control signal is only generated if at least one of the left channel and right channel output signals of the second means exceeds the associated left channel or right channel input signal of the first means.

25 By using this measure the stereo image enhancement reduction only takes place if it can have a positive effect. If the output signals of the second means do not exceed the input signals of the first means, then a reduction of the stereo image enhancement will have no positive effect on distortion and the reduction should not be done at all in order to avoid any possibly detrimental effects of such a reduction.

30

The above object and features of the present invention will be more apparent from the following description of the preferred embodiments with reference to the drawings, wherein:

Figure 1 shows an embodiment of a known stereophonic audio reproduction system,

Figure 2 shows a first embodiment of a stereophonic audio reproduction system according to the invention,

5 Figure 3 shows a second embodiment of a stereophonic audio reproduction system according to the invention,

Figure 4 shows an embodiment of control means for use in the present invention,

10 Figure 5 shows an embodiment for an audio-visual reproduction system in the form of, for example, a television set or a so-called multimedia audio-visual system. In the figures, identical parts are provided with the same reference numbers.

Figure 1 shows an embodiment of a known stereophonic audio reproduction system. The stereophonic audio reproduction system comprises a stereophonic processing arrangement including a stereo enhancement circuit 10 for processing a left channel and right channel input signals R_i and L_i into left channel and right channel output signals L_o and R_o , respectively, and amplifying means 20 for amplifying and supplying the left channel and right channel output signals L_o and R_o to respective left channel and right channel loudspeakers 30 and 40. Such a system is in principle known from EP-A 664661. The stereo enhancement circuit 10 comprises first means 100, having a first input for receiving the left channel input signal L_i , a second input for receiving the right channel input signal R_i , a first output for providing a left channel signal L_s and a second output for providing a right channel signal R_s . The left and right channel signals L_s and R_s have an enhanced stereo image as compared to the signals L_i and R_i . For a more detailed description of the first means 100, reference is made to EP-A 664 661. The stereo enhancement circuit 10 further comprises second means for controllably combining the left channel signals L_i and L_s and the right channel signals R_i and R_s . The second means comprises:

- first and second subtractors 102 and 104 for providing the subtracted pairs of signals $L_i - L_s$, and $R_i - R_s$, respectively to respective controllable attenuators 106 and 108, each having a controllable gain equal to α , wherein $0 \leq \alpha \leq 1$,
- third and fourth adders 110 and 112 for adding the output signal of the first and second controllable attenuators 106 and 108 to signals L_i and R_i , thereby providing the left channel and right channel output signals L_o and R_o .

15
20
25
30

In this way the output signals L_o and R_o are formed according to the formulas:

$$L_o = \alpha * L_s + (1-\alpha) * L_i$$

$$R_o = \alpha * R_s + (1-\alpha) * R_i.$$

By varying parameter α between 0 and 1 the stereo effect in the output signal formed by left
5 channel and right channel signals L_o and R_o can be varied between a normal, i.e. conventional, stereo image for $\alpha = 0$ to a fully enhanced stereo image for $\alpha = 1$. The second means can be implemented in other ways as well, for example by providing separate controllable attenuators for each of the signals L_i , R_i , L_s and R_s , having respective controllable gains of $(1-\alpha)$, $(1-\alpha)$, α and α , and adding the resulting pairs of attenuated
10 signals L_i , L_s , and R_i , R_s .

For $\alpha < > 0$ the amplitude of each of the resulting signals L_o and R_o can be larger than the original signals L_i and R_i . This difference may be as high as 12 dB or more. This is due to the fact that the stereo image enhancement is achieved by adding a significant amount of negative cross-talk to the left and right channels. When reproduced by
15 loudspeakers, a part of these signals is acoustically cancelled as a result. The extra 12 dB gain is necessary to achieve substantially the same sound level as for normal stereo. This means that for reproduction of stereo signals having an enhanced stereo image, the amplifying means which amplify such signals as well as the loudspeakers that reproduce these signals should have a larger dynamic range than required for normal stereo signals.

Figure 2 shows a first embodiment of a stereophonic audio reproduction system according to the invention. Figure 2 differs from Figure 1 in that control means
20 have been added, the control means 50 receiving as input signals the left channel and right channel output signals L_{os} and R_{os} of the amplifying means 20 and supplying a control signal representing α to the signal enhancement circuit 10 for controlling the stereo image enhancement. The control means 50 are used for controlling the combining of the stereo signals so as to reduce the stereo image enhancement at high signal levels. When either signal L_{os} or R_{os} exceeds a threshold value, the control signal α supplied by the control means 50 is reduced accordingly. This threshold value is the value of the output signal above
25 which the amplification of the amplifying means 20 becomes non-linear. An advantage of this embodiment is that the control signal α is directly derived from the signals undergoing
30 distortion.

Figure 3 shows a second embodiment of a stereophonic audio reproduction system according to the invention. Figure 3 differs from Figure 2 in that volume level setting means 60 are added and in that the control means 50 now receive three

groups A, B and C of input signals, instead of one group of signals. Group A comprises the left channel and right channel input signals L_i and R_i , group B comprises the left channel and right channel output signals L_o and R_o of the signal enhancement circuit 10 and group C comprises a signal VL representative of the volume level setting. The volume level setting means 60 supplies a signal VL representative of the volume level setting to the amplifying means 20 for setting the volume level. For this purpose the amplifiers of the amplifying means 20 each have a controllable gain, the gain being controlled by said signal VL. The groups A, B and C can be used separately or in combination with each other for generating the control signal α . When only the group A and group C signals are used, the control means 50 calculate from the set volume level the maximum level of an input signal applied to the amplifying means above which maximum level or threshold the amplification becomes non-linear. This threshold value is reduced by 12 dB to take into account the extra signal level needed for reproducing the enhanced stereo signals. If the level of the input signal exceeds this maximum level or threshold, then the control means 50 reduce α accordingly.

When only the group B and group C signals are used, the control means 50 differ only from the control means 50 used for group A and group C signals in that it is no longer necessary to deduct the 12 dB from the maximum level as now the output signals of the stereo enhancement circuit 10 are used instead of its input signals. If the volume level adjustment is made before the stereo enhancement circuit 10, the signal VL need not be used as the maximum level or threshold can now have a fixed value. In this case the group C signal can be dispensed with. The correction or reduction of α need only be of the amount required to avoid this distortion. For example, when a reduction of signal level of only 6 dB is needed, α need only be reduced to 0.5. It is also possible to use only the group C signal, i.e. the signal VL representative of the set volume level. This results in a very simple solution for the control means 50 as no signal measurements take place. α will now be reduced if the set volume level is so high that an input signal having a maximum allowed signal level will undergo distortion. Of course the 12 dB extra margin is taken into account here as well. However, this means that α may be reduced even if no distortion takes place, i.e. if the actual signal level remains below the threshold.

Figure 4 shows an embodiment of control means for use in the present invention. The control means 50 is an improvement on the control means 50 discussed in connection with Figure 3. In the control means 50 of Figure 4 all three groups A, B and C are used for generating the control signal α . The control means 50 comprises first to fifth preprocessing means 500, 502, 504, 506 and 508, first and second comparators 510 and 512,

first and second controlled switches 514 and 516, adding means 518, envelope detector 520, subtracting means 522 and amplifying means 524. The first comparator 510, together with the first and second preprocessing means 500 and 502 and the first controlled switch 514 act as a selective peak detector to pass on to the adding means 518 only those peaks in the Lo
5 signal, which exceed the envelope of the Li signal. For this purpose the signal Li is applied to the positive input of the first comparator 510 via preprocessing means 500, in this case an envelope detector. The signal Lo is applied to both the controllable switch 514 and the negative input of the comparator 510 via preprocessing means 502, in this case a rectifier. When peaks in the rectified signal of Lo exceed the envelope of signal Li, the first
10 comparator 510 activates the controlled switch 514 and the rectified signal Lo will be passed on to the adding means 518. A similar processing of the signals Ri and Ro is performed by the second comparator 512, together with the third and fourth preprocessing means 504 and 506 and the second controlled switch 516. In this example the preprocessing means 504 comprises an envelope detector and the preprocessing means 506 comprises a rectifier. In the
15 adding means 518 the larger of the two signals applied to the adding means 518 is passed on to an envelope detector 520. The output signal of envelope detector 520 is then subtracted from a signal derived from the signal VL, which is in its turn representative of the set volume level. The signal resulting from the subtraction is then amplified by amplifying means 524 and is the control signal α to be supplied to the stereo enhancement circuit 10 of
20 Figure 3. The signal derived from signal VL is a threshold above which the amplification in the amplifying means 20 becomes non-linear. This signal may be derived from VL as follows. At a given volume level setting, it is determined experimentally or theoretically at what amplitude an input signal supplied to the amplifying means 20 will be amplified non-linearly. This results in a threshold which may not be exceeded by input signals at that given
25 volume level setting. At a new (different) volume level setting, this threshold can be recalculated using the difference between the given volume level setting and the new volume level setting. Thus, when the new volume level setting is 6 dB lower, the threshold should be increased correspondingly by 6 dB. In this way, the peak values of the signals Lo and Ro reduce the value of α when these peak values exceed the threshold. The use of the selective
30 peak detectors ensure that α is only reduced when it will have an effect, i.e. when the signals Lo and Ro have got larger amplitudes than the signals Li and Ri. If this were not done, α would be reduced even when it does not have any positive effect on distortion reduction. It may even be so that for some input signals a reduction of α can result in an increase of the output signal level. This depends on the phase difference between the left and right channel

input signals. This effect could result in an unstable feedback loop, but is avoided when the selective peak detectors as described previously are used. These selective peak detectors may also be used advantageously in the control means 50 of Figure 2 for prohibiting the reduction of α when no beneficial effect can be expected from this reduction. The preprocessing means 500, 502, 506 and 508 may also comprise other processing than the mentioned rectification or envelope detection, for example an averaging or peak detection etc. The envelope detector 520 may also be replaced by other processing, such as peak detection, averaging etc. The amplifying means 524 are used for providing sufficient loop gain in the feedback loop for controlling α . By this feedback the time constants of the envelope detectors are apparently reduced. However, when the feedback loop is open, i.e. when controlled switches 514 and 516 are not activated to pass signals L_o and R_o , respectively, the time constants appear at their normal value. This may result in a long settling time of the system. Therefore it may be desirable to decrease the time constants of the envelope detectors when the feedback loop is open, in particular the time constant of the envelope detector 520. Other methods for deriving α may also be used. For example, the signals L_{os} and R_{os} may also be used in any combination with the groups A, B and/or C signals for deriving the control signal α therefrom. The control signal α may undergo additional smoothing by incorporating a low-pass filter (not shown) following the amplifier 524 of Figure 4. In the embodiment of figure 3 the control signal α will usually be generated a little late, due to the feedback nature of the generation of the control signal α . If desired this may be compensated by inserting delays before the amplifier 20. The invention may also be used to increase α by increasing α such that the output signal reaches the level above which the amplification of the amplifier 20 becomes non-linear. In this way the Incredible Sound effect may be maximized.

Figure 5 shows an embodiment for an audio-visual reproduction system in the form of, for example, a television set or a so-called multimedia audio-visual system. The audio-visual reproduction system comprises a cabinet 70 which accommodates a picture display screen 72 for displaying video pictures. To the left of the picture display screen 72 the left channel loudspeaker 30 is positioned. The right channel loudspeaker 40 is positioned to the right of the picture display screen 72. The left channel loudspeaker 30 and the right channel loudspeaker 40 are controlled by the stereophonic audio signal processing arrangement shown in Fig. 2 or 3.

CLAIMS:

1. A stereophonic audio signal processing arrangement comprising:
 - signal processing means, including a stereo enhancement circuit for processing a stereo input signal,
 - signal amplifying means for amplifying a stereo output signal supplied by the
- 5 said stereo enhancement circuit comprising:
 - first means having a first and a second input for receiving a left channel and a right channel signal of the stereo input signal and a first and a second output for supplying a left channel and a right channel signal of a stereo signal having an
- 10 enhanced stereo image,
 - second means for controllably combining the stereo input signal and the stereo output signal of the first means for varying the stereo image enhancement,
- 15 characterized in that the stereo enhancement circuit comprises control means coupled to the second means for controlling the combining of the stereo signals so as to reduce the stereo image enhancement at high signal levels.
2. The arrangement of Claim 1, characterized in that the arrangement comprise volume level setting means supplying a signal representative of a volume level to the amplifying means for setting the volume level, and to the control means for controlling the combining as a function of the set volume level.
- 20 3. The arrangement of Claim 1, characterized in that the control means comprise means for comparing the signal level of the amplified stereo output signal with a reference level and supplying a control signal to the second means for reducing the stereo image enhancement when the signal level exceeds the reference level.
4. The arrangement of Claim 1 or 2, characterized in that the control means
- 25 comprise means for comparing the signal level of the stereo output signal of the second means with a reference level and supplying a control signal to the second means for reducing the stereo image enhancement when the signal level exceeds the reference level.
5. The arrangement of Claim 3 or 4, characterized in that the reference level is a function of the set volume level.

6. The arrangement of Claim 2, 3, 4 or 5, characterized in that the control signal is only generated if at least one of the left channel and right channel output signals of the second means exceeds the associated left channel or right channel input signal of the first means.

5 7. A stereophonic audio reproduction system including the stereophonic audio signal processing arrangement of Claim 1, 2, 3, 4, 5 or 6, left channel and right channel loudspeakers for reproducing the amplified stereo signal supplied by the signal amplifying means.

8. An audio-visual reproduction system including the stereophonic audio reproduction system of Claim 7, a cabinet in which a picture display screen and the left channel and right channel loudspeakers are installed.

9. A stereo enhancement circuit comprising:

- first means having a first and a second input for receiving a left channel and a right channel signal of the stereo input signal and a first and a second output for supplying a left channel and a right channel signal of a stereo signal having an enhanced stereo image,

- second means for controllably combining the stereo input signal and the stereo output signal of the first means for varying the stereo image enhancement,

15 characterized in that the stereo enhancement circuit further comprises control means coupled to the second means for controlling the combining of the stereo signals so as to reduce the stereo image enhancement at high signal levels.

10. A method for enhancing a stereo image of a stereo input signal, comprising the steps of:

- generating a stereo output signal having an enhanced stereo image from the stereo input signal,

25 - controllably combining the stereo input signal and the stereo output signal to provide a processed stereo output signal,

characterized in that the combining is controlled so as to reduce the stereo image enhancement at high signal levels.

1/3

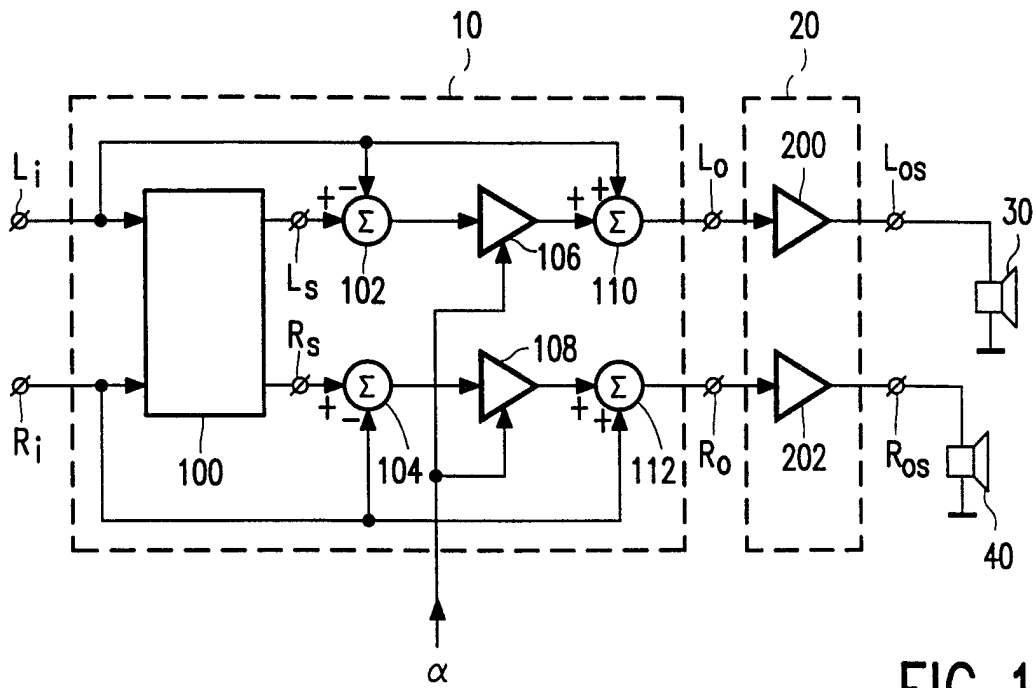

FIG. 1

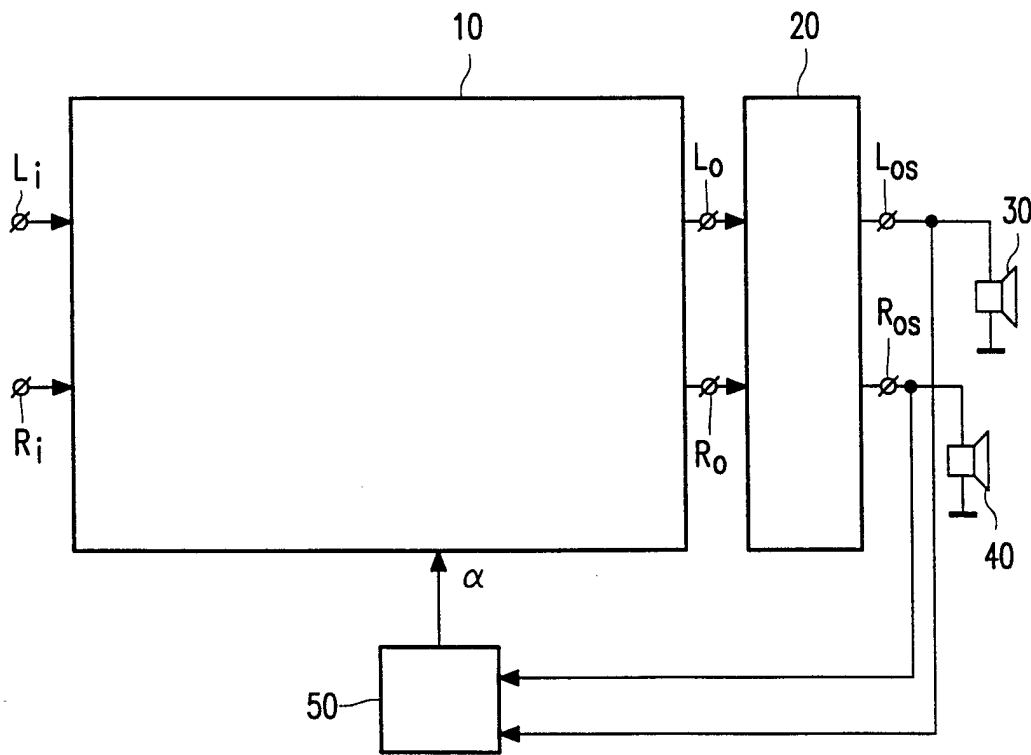

FIG. 2

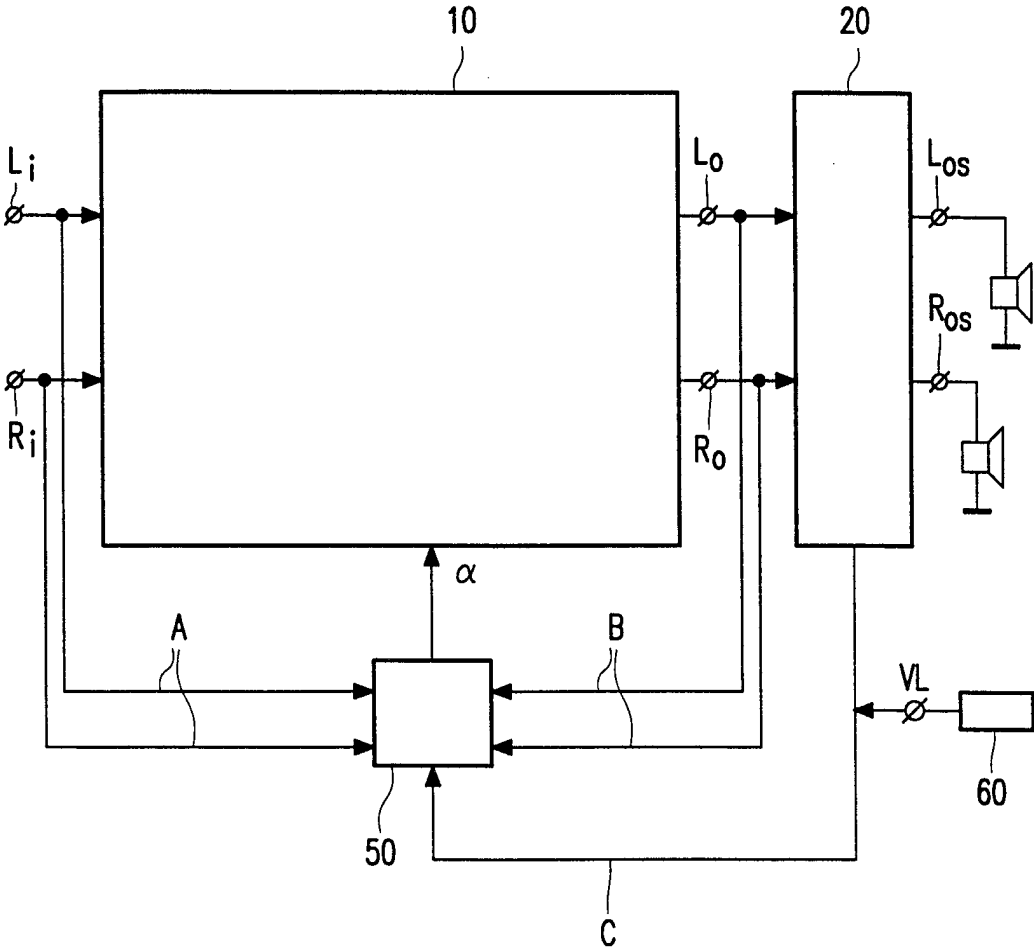

FIG. 3

3/3

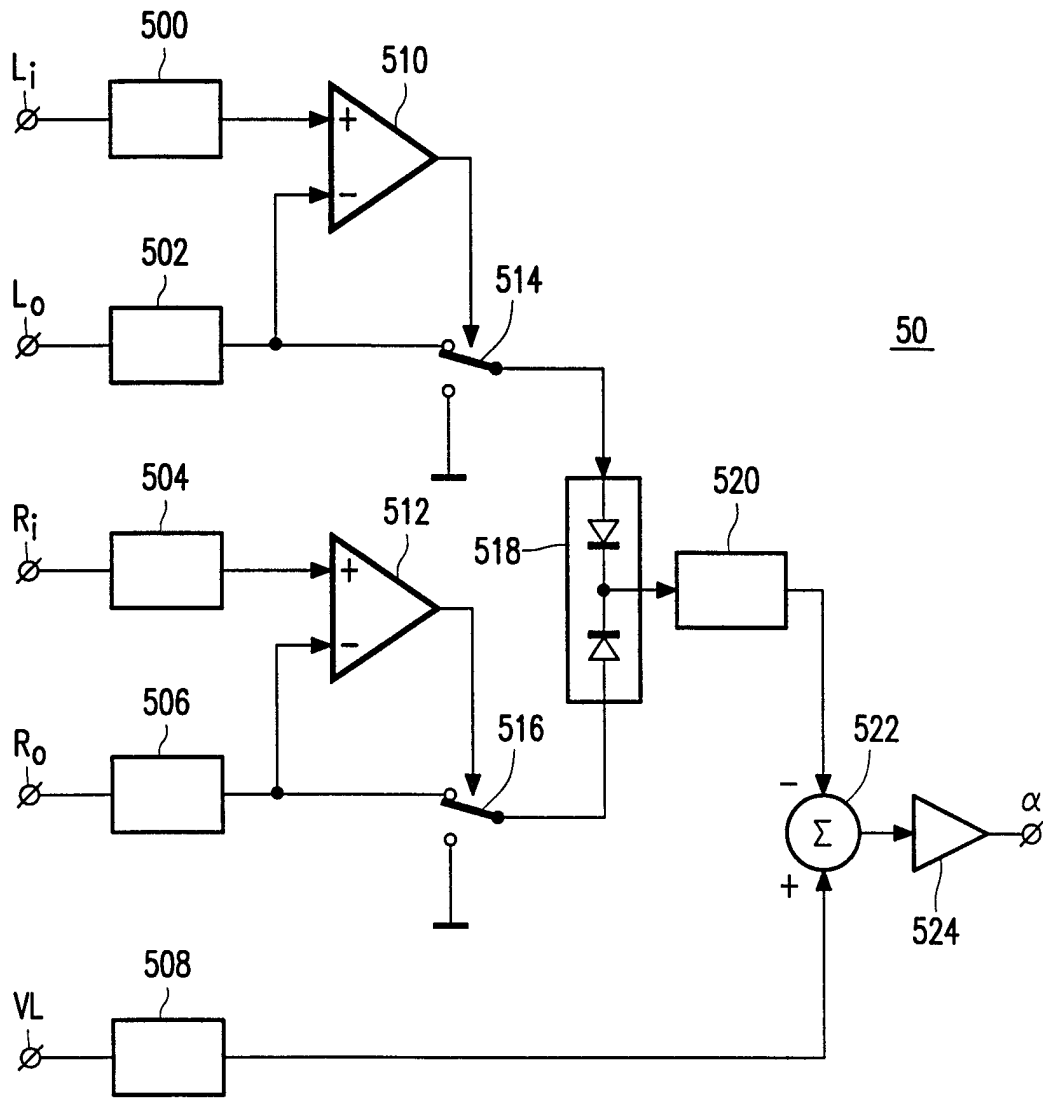

FIG. 4

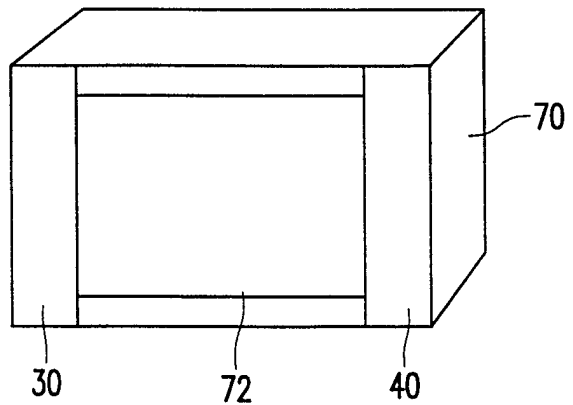

FIG. 5

INTERNATIONAL SEARCH REPORT

International application No.
PCT/IB 97/01203

A. CLASSIFICATION OF SUBJECT MATTER

IPC6: H04S 1/00

According to International Patent Classification (IPC) or to both national classification and IPC

B. FIELDS SEARCHED

Minimum documentation searched (classification system followed by classification symbols)

IPC6: H04S

Documentation searched other than minimum documentation to the extent that such documents are included in the fields searched

SE,DK,FI,NO classes as above

Electronic data base consulted during the international search (name of data base and, where practicable, search terms used)

EPODOC

C. DOCUMENTS CONSIDERED TO BE RELEVANT

Category*	Citation of document, with indication, where appropriate, of the relevant passages	Relevant to claim No.
Y	EP 0664661 A1 (PHILIPS ELECTRONICS N.V.), 26 July 1995 (26.07.95) --	1,3,4,6-10
Y	US 4696036 A (JULSTROM), 22 Sept 1987 (22.09.87) --	1,3,4,6-10
Y	US 4866774 A (KLAYMAN), 12 Sept 1989 (12.09.89) --	1,3,4,6-10
Y	Audio, Volume 65, No 2, February 1981, (New York), Gary Stock, "DvR's Latest: The Analog Bass Computer" page 24 --	1,3,4,6-10

 Further documents are listed in the continuation of Box C. See patent family annex.

* Special categories of cited documents:

"A" document defining the general state of the art which is not considered to be of particular relevance

"E" earlier document but published on or after the international filing date

"L" document which may throw doubts on priority claim(s) or which is cited to establish the publication date of another citation or other special reason (as specified)

"O" document referring to an oral disclosure, use, exhibition or other means

"P" document published prior to the international filing date but later than the priority date claimed

"T" later document published after the international filing date or priority date and not in conflict with the application but cited to understand the principle or theory underlying the invention

"X" document of particular relevance: the claimed invention cannot be considered novel or cannot be considered to involve an inventive step when the document is taken alone

"Y" document of particular relevance: the claimed invention cannot be considered to involve an inventive step when the document is combined with one or more other such documents, such combination being obvious to a person skilled in the art

"&" document member of the same patent family

Date of the actual completion of the international search

3 February 1998

Date of mailing of the international search report

03 -02- 1998

Name and mailing address of the ISA/
Swedish Patent Office
Box 5055, S-102 42 STOCKHOLM
Facsimile No. +46 8 666 02 86

Authorized officer

Leif Vingård
Telephone No. +46 8 782 25 00

INTERNATIONAL SEARCH REPORT

International application No.

PCT/IB 97/01203

C (Continuation). DOCUMENTS CONSIDERED TO BE RELEVANT

Category*	Citation of document, with indication, where appropriate, of the relevant passages	Relevant to claim No.
Y	Audio, Volume 68, No 8, August 1984, (New York), J. Selmer Jensen and S.K. Pramanik, "Dynamic bias control with HX Professional" page 34; page 36 - page 41 --	1,3,4,6-10
Y	Audio, Volume 68, No 11, November 1984, (New York), Advertisement, "Dolby HX Pro." page 31 -- -----	1,3,4,6-10

INTERNATIONAL SEARCH REPORT
Information on patent family members

07/01/98

International application No.
PCT/IB 97/01203

Patent document cited in search report	Publication date	Patent family member(s)	Publication date
EP 0664661 A1	26/07/95	AU 1022895 A BE 1008027 A CN 1121302 A JP 7222296 A WO 9604093 A	27/07/95 12/12/95 24/04/96 18/08/95 15/02/96
US 4696036 A	22/09/87	NONE	
US 4866774 A	12/09/89	AU 614191 B AU 4310489 A CA 1309031 A DE 68928180 D,T EP 0400106 A,B EP 0773702 A JP 3502635 T WO 9005438 A	22/08/91 28/05/90 20/10/92 13/11/97 05/12/90 14/05/97 13/06/91 17/05/90