



US 20110000497A1

(19) **United States**

(12) **Patent Application Publication**  
**Wanna**

(10) **Pub. No.: US 2011/0000497 A1**

(43) **Pub. Date: Jan. 6, 2011**

(54) **SMOKING ARTICLES HAVING REDUCED ANALYTE LEVELS AND PROCESS FOR MAKING SAME**

(75) **Inventor: Joseph T. Wanna, Alpharetta, GA (US)**

Correspondence Address:  
**DORITY & MANNING, P.A.**  
**POST OFFICE BOX 1449**  
**GREENVILLE, SC 29602-1449 (US)**

(73) **Assignee: SCHWEITZER-MAUDUIT INTERNATIONAL, INC., Alpharetta, GA (US)**

(21) **Appl. No.: 12/883,890**

(22) **Filed: Sep. 16, 2010**

**Related U.S. Application Data**

(63) **Continuation of application No. 11/052,454, filed on Feb. 7, 2005.**

**Publication Classification**

(51) **Int. Cl.**  
*D21H 19/00* (2006.01)  
*D21F 11/00* (2006.01)

(52) **U.S. Cl. .... 131/365; 162/139**

(57) **ABSTRACT**

Smoking articles having reduced Hoffmann analytes contained in the mainstream smoke is disclosed. In one embodiment, an alginate composition is applied to a wrapper that is incorporated into a smoking article. The alginate composition causes a significant reduction in at least certain of the Hoffmann analytes that are generated when the smoking article is smoked. The alginate composition may be applied so as to cover a substantial portion of the surface area of the wrapper in one embodiment. In another embodiment, the alginate composition is applied as a single band to the paper wrapper so to cover a substantial portion of the distal end of the smoking article.

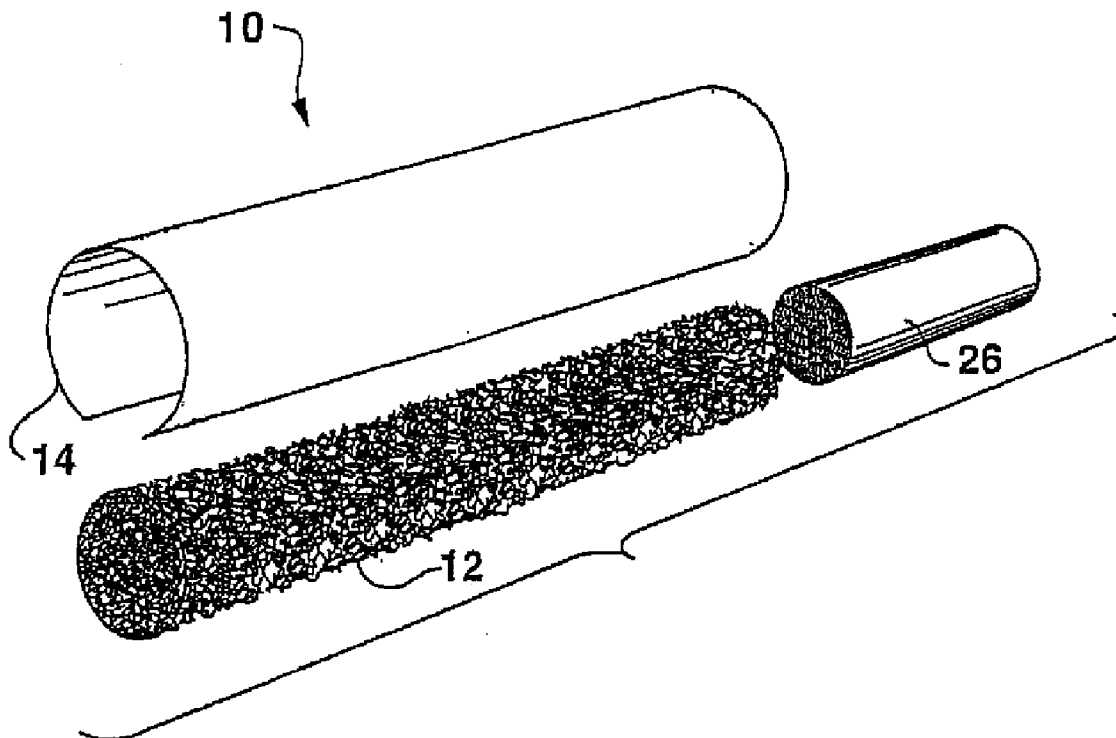

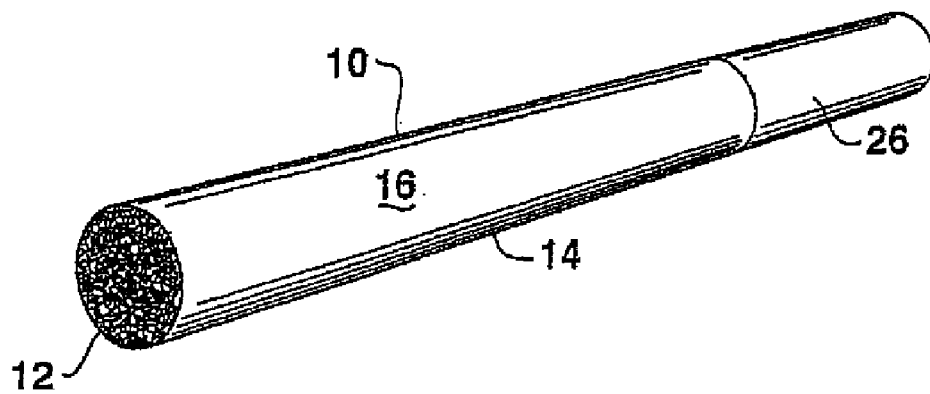

**FIG. 1**

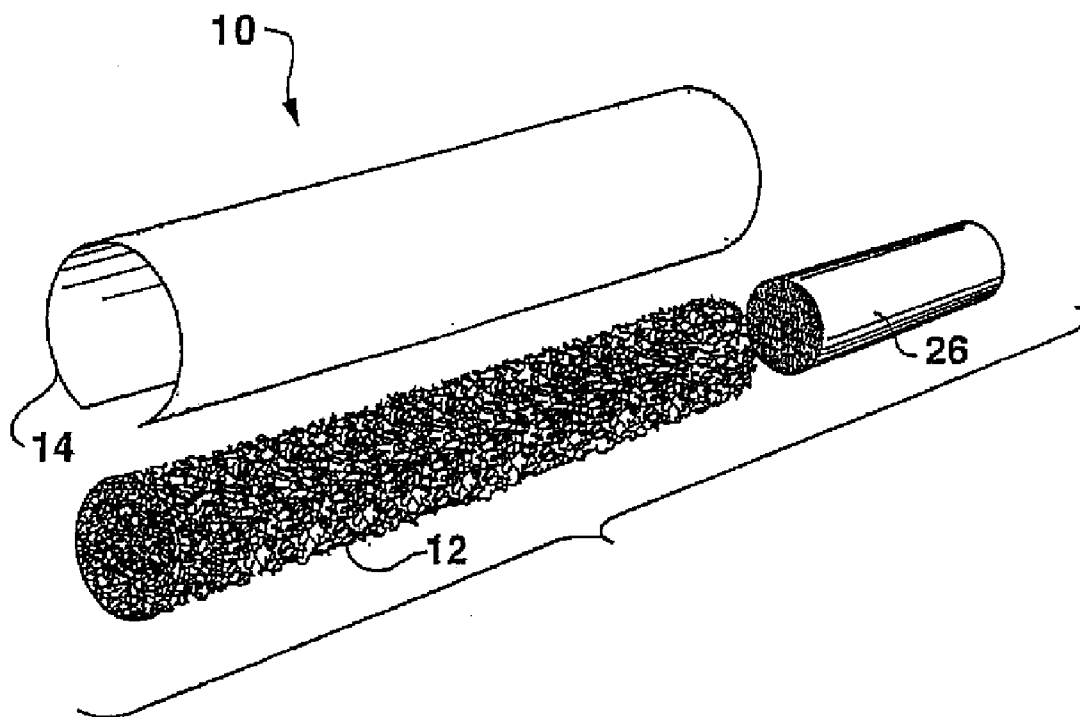

**FIG. 2**

**SMOKING ARTICLES HAVING REDUCED  
ANALYTE LEVELS AND PROCESS FOR  
MAKING SAME**

RELATED APPLICATIONS

[0001] The present application is a continuation of and claims priority to U.S. patent application Ser. No. 11/052,454, filed on Feb. 7, 2005.

BACKGROUND OF THE INVENTION

[0002] Smoking articles such as cigarettes are conventionally made by wrapping a column of tobacco in a white wrapping paper. At one end, the smoking article usually includes a filter through which the article is smoked. Filters are attached to smoking articles using a tipping paper which is glued to the white wrapping paper. The wrapping papers and tipping papers used to construct smoking articles are typically made from flax or other cellulosic fibers and contain a filler, such as calcium carbonate.

[0003] When a smoking article is smoked, mainstream smoke is generated that is inhaled through the filter. Mainstream smoke can contain numerous different components that provide the smoking article with a particular taste, which encompasses the sensations detected not only by one's taste but also by one's sense of smell. In order to provide a smoking article with a particular taste, as many as over 500 different ingredients may be added to the tobacco at different levels. In addition to the components of mainstream smoke that contribute to the taste of the smoking article, the mainstream smoke can also contain various other analytes. For example, D. Hoffmann of the American Health Foundation recognized 44 different analytes that may be present in mainstream smoke. These analytes are typically referred to as "Hoffmann analytes" and include, for instance, ammonia, aminonaphthalenes, benzopyrene, formaldehyde, acetaldehyde, acetone, methyl ethyl ketone, butyraldehyde, hydrogen cyanide, nitrous oxides, tobacco-specific nitrosamines ("TSNAs"), pyridine, quinoline, hydroquinone, phenol, cresols, tar, nicotine, carbon monoxide, 1,3-butadiene, isoprene, acrylonitrile, benzene, toluene, styrene, and various others.

[0004] It has been determined that some Hoffmann analytes may be unwanted in the mainstream smoke from a smoking article. As such, extensive research has been conducted on reducing Hoffmann analytes.

[0005] Besides being used to hold smoking articles together, wrapping papers also contribute to and control many physical properties and characteristics of the smoking article. For instance, cigarette wrapping papers affect the rate at which the cigarette burns, the number of puffs per cigarette, tar, various volatile analytes, and the total tar delivery per puff. What is needed, however, is a cigarette wrapping paper that may additionally be used to reduce the amount of at least one Hoffmann analyte in the mainstream smoke of a smoking article.

SUMMARY OF THE INVENTION

[0006] In general, the present invention is directed to a method for reducing at least one Hoffmann analyte in the mainstream smoke of a smoking article and is directed to smoking articles made by the above methods. More particularly, the present invention is directed to a wrapping paper for

smoking articles that is treated with a chemical composition that has been found to reduce the amount of Hoffmann analytes in mainstream smoke.

[0007] For example, in one embodiment, the present disclosure is directed to a smoking article comprising a column of a smokeable tobacco. The column of the smokeable tobacco is surrounded by a paper wrapper. In accordance with the present invention, the paper wrapper includes areas where an alginate composition is present. The alginate composition is present in an amount sufficient to reduce at least one Hoffmann analyte in a mainstream smoke generated by the smoking article when ignited.

[0008] In the past, alginate materials have been applied to paper wrappers for smoking articles in order to produce smoking articles having reduced ignition proclivity, which refers to the tendency of the smoking article to ignite surfaces which come into contact with the smoking article when lit. Using alginate compositions for reducing the ignition proclivity of smoking articles is disclosed, for instance, in U.S. Pat. No. 5,820,998 and in U.S. Pat. No. 6,779,530, which are both incorporated herein by reference. When applied for the purpose of reducing ignition proclivity, alginate compositions are typically applied to form treated discrete areas on the wrapping paper, such as in the form of circular bands.

[0009] In comparison to reducing ignition proclivity, the process of the present invention is directed to reducing at least one Hoffmann analyte contained in the mainstream smoke. Thus, the alginate composition may be applied using different techniques and in a different manner. For instance, instead of forming circular bands, the alginate composition may be applied in a uniform manner over substantially the entire surface area of the wrapping paper. Also, in some applications, lesser amounts of the alginate composition may be required in order to reduce Hoffmann analytes as opposed to when the alginate composition is used for reduced ignition proclivity.

[0010] In other applications, when an alginate composition is applied to a paper wrapper for reducing Hoffmann analytes, the alginate composition may, in some embodiments, not significantly affect the permeability of the paper wrapper. For instance, the permeability of the paper wrapper may be reduced by no more than about 60%, such as by no more than 50%. For example, the permeability of the paper wrapper may be reduced by no more than about 40%, such as by no more than 30%, such as by no more than 20%, or by no more than 10% in areas where the alginate composition is present.

[0011] Thus, the permeability of the paper wrapper in the areas where the alginate composition is applied according to the present invention may be greater than about 25 Coresta, such as greater than about 30 Coresta, such as greater than 35 Coresta or even greater than 40 Coresta. The alginate composition may be applied to the paper wrapper, for instance, in an amount from about 0.25% to about 10% by weight. For instance, in some embodiments, the alginate composition may be present in an amount from about 0.75% to about 5% by weight, while in other applications the alginate composition may be present in an amount from about 5% to about 8% by weight.

[0012] The alginate composition that is applied according to the present invention can vary depending upon the particular application. For instance, the alginate composition may comprise a sodium alginate, a potassium alginate, an ammo-

nium alginate, mixtures thereof, and the like. The alginate composition may have any suitable molecular weight or viscosity.

**[0013]** The alginate composition may be incorporated into the paper wrapper using various techniques. For example, in one embodiment, the alginate composition may be topically applied to the paper wrapper. For instance, the alginate composition may be applied using a size press during production of the paper wrapper. Alternatively, the alginate composition may be topically applied to the paper wrapper after the wrapper has been formed. In these embodiments, for instance, a printing device may be used in order to apply the alginate, such as a rotogravure printing device, a flexographic printing device, and the like. In still other embodiments, the alginate composition may be sprayed onto the paper wrapper.

**[0014]** Instead of being topically applied to the paper wrapper, the alginate composition may also be otherwise incorporated into the paper wrapper. For instance, in one embodiment, the alginate composition may be combined with an aqueous suspension of fibers which are then used to form the paper wrapper.

**[0015]** Once an alginate composition is applied to a paper wrapper in accordance with the present invention, smoking articles made from the paper wrapper have been found to exhibit significant reductions in certain Hoffmann analyte levels in the mainstream smoke. For instance, it is believed that the alginate composition can reduce formaldehyde contained in the mainstream smoke by at least 10%, such as by at least 15%. Aminonaphthalenes contained in the mainstream smoke may be reduced by at least 3%, such as at least 5%, and, in one embodiment, by at least 10%. Ammonia contained in the mainstream smoke may be reduced by at least 10%, such as by at least 20%. Nitrous oxides may be reduced in the mainstream smoke by at least 10%, such as at least 15%, or at least 20%. Hydrogen cyanide levels in the mainstream smoke may be reduced by at least about 2%, such as by at least about 5%. In addition to the above, tobacco-specific nitrosamines may be reduced by at least 3%, such as by at least 5%, or by at least 10% in the mainstream smoke. Still other Hoffmann analytes that may be reduced according to the present invention in mainstream smoke include acrolein, other carbonyls, and aromatic amines.

**[0016]** Other features and aspects of the present invention are described in more detail below.

#### BRIEF DESCRIPTION OF THE DRAWINGS

**[0017]** A full and enabling disclosure of the present invention, including the best mode thereof to one of ordinary skill in the art, is set forth more particularly in the remainder of the specification, including reference to the accompanying figures in which:

**[0018]** FIG. 1 is a perspective view of a smoking article made in accordance with the present invention; and

**[0019]** FIG. 2 is an exploded view of the smoking article illustrated in FIG. 1.

**[0020]** Repeat use of reference characters in the present specification and drawings is intended to represent the same or analogous features or elements of the present invention.

#### DETAILED DESCRIPTION

**[0021]** It is to be understood by one of ordinary skill in the art that the present discussion is a description of exemplary

embodiments only, and is not intended as limiting the broader aspects of the present invention.

**[0022]** In general, the present invention is directed to wrappers for smoking articles that are particularly designed to reduce at least one Hoffmann analyte in the mainstream smoke of the smoking article. The present disclosure is also directed to various methods for producing the wrappers. In one embodiment, for instance, the present invention is directed to incorporating an alginate composition into the wrapper in a manner that causes a reduction in certain Hoffmann analyte compounds in the smoke produced by a smoking article made with the wrapper. For example, reductions have been observed in certain carbonyls, such as formaldehyde, acetaldehyde, acrolein, and the like, in certain aromatic amines such as aminonaphthalenes, in nitrous oxides, and in ammonia. Of particular advantage, alginates can be incorporated into wrappers in accordance with the present invention without substantially affecting any other properties of the wrapper or the taste and appearance of the smoking article.

**[0023]** For purposes of explanation, the embodiments and principles of the invention will be discussed in regards to a cigarette. However, this is for purposes of explanation of the invention only and is not meant to limit the invention only to cigarettes. Any manner of smoking article is within the scope and spirit of the invention. For instance, it is believed that the principles of the present invention also apply to cigars and the like.

**[0024]** In general, an alginate is a derivative of an acidic polysaccharide or gum which occurs as the insoluble mixed calcium, sodium, potassium and magnesium salt in the Phaeophyceae brown seaweeds. Generally speaking, these derivatives are calcium, sodium, potassium, and/or magnesium salts of high molecular weight polysaccharides composed of varying proportions of D-mannuronic acid and L-guluronic acid. Exemplary salts or derivatives of alginic acid include ammonium alginate, potassium alginate, sodium alginate, propylene glycol alginate, and/or mixtures thereof.

**[0025]** In the past, alginates have been used to form bands or other discrete areas on cigarette wrapping papers in order to decrease the ignition proclivity characteristics of a smoking article incorporating the wrapper. For example, such wrapping papers are disclosed in U.S. Pat. No. 5,820,998, in U.S. Pat. No. 5,878,753, in U.S. Pat. No. 6,568,403, in U.S. Pat. No. 6,725,867, and in U.S. Pat. No. 6,779,530, which are all incorporated herein by reference.

**[0026]** As mentioned above, the above patents relate to using alginates for forming smoking articles having improved ignition proclivity control characteristics. "Ignition proclivity" is a measure of the tendency of the smoking article or cigarette to ignite a flammable substrate if the burning cigarette is dropped or otherwise left on a flammable substrate. A test for ignition proclivity of a cigarette has been established by NIST (National Institute of Standards and Technology) and is generally referred to as the "Mock-Up Ignition Test". The test comprises placing a smoldering cigarette on a flammable test fabric and recording the tendency of the cigarette to either ignite the test fabric, burn the test fabric beyond a normal char line of the fabric, burn its entire length without igniting the fabric, or self-extinguish before igniting the test fabric or burning its entire length.

**[0027]** Another test for ignition proclivity is referred to as the "Cigarette Extinction Test". In the Cigarette Extinction Test, a lit cigarette is placed on one or more layers of filter paper. If the cigarette self extinguishes, the cigarette passes

the test. If the cigarette burns all the way to its end on the filter, however, the cigarette fails. Smoking articles made in accordance with the present invention can be designed to pass one or both of these tests.

**[0028]** In general, smoking articles having reduced ignition proclivity are made by applying the alginate in discrete areas in amounts sufficient so that the smoking article will pass one of the above tests. As described in U.S. Pat. No. 5,820,998, in the past, alginates have been applied to the discrete areas in amounts that cause a substantial reduction in the permeability of the paper. For example, as stated in U.S. Pat. No. 5,820,998, the permeability of the paper coated with the alginate is generally at least about 75% less than the permeability of an identical uncoated portion of the paper.

**[0029]** According to the present invention, on the other hand, an alginate composition is applied to a paper wrapper in order to primarily reduce the amount of Hoffmann analytes contained in the mainstream smoke of a smoking article. In this regard, in order to maximize Hoffmann analyte reduction, alginates may be applied in different amounts and/or in a different manner in comparison to many prior art products that incorporated alginates for reduced ignition proclivity characteristics. For example, according to the present invention, instead of being applied to paper wrappers in spaced-apart areas such as bands, an alginate composition may be applied to a paper wrapper according to the present invention so as to substantially cover the entire surface area of the paper wrapper. For instance, the alginate composition may be applied so as to cover over 60% of the surface area of the paper wrapper, such as over 70%, such as over 80%, and even over 90% of the surface area of the paper wrapper.

**[0030]** When topically applied to the paper wrapper, the alginate composition may be applied continuously or discontinuously. When applied discontinuously, for instance, the alginate composition may appear as a pattern that includes untreated areas on the paper wrapper. The untreated areas on the paper wrapper, however, may amount to a small portion of the overall surface area of the paper wrapper.

**[0031]** Alginate compositions may also be incorporated into paper wrappers according to the present invention in a manner so as to not significantly interfere with the properties of the wrapper. For example, in comparison to many prior art products where alginate compositions were used to reduce ignition proclivity characteristics, alginate compositions may be applied to wrappers according to the present invention without substantially decreasing the permeability of the wrapper. For example, alginate compositions may be applied to paper wrappers according to the present invention in amounts such that the permeability of the paper wrapper decreases by no more than about 60%, such as no more than about 50%, such as by no more than about 40%, and, in one embodiment, may be applied so as to decrease the permeability by no more than about 30%. Of particular advantage, it is believed that relatively low amounts of an alginate composition may be applied to the wrapper and still be effective in reducing at least one Hoffmann analyte of a mainstream smoke of a smoking article incorporating the wrapper.

**[0032]** Paper wrappers made according to the present invention are capable of reducing various Hoffmann analytes in the mainstream smoke generated by a smoking article incorporating the wrapper. Currently, there are 44 different Hoffmann analytes that are associated with mainstream cigarette smoke. Hoffmann analytes that may be reduced according to the present invention include ammonia, aminonaphtha-

lenes, aminobiphenyl, benzopyrenes, formaldehyde, acetaldehyde, acetone, acrolein, propionaldehyde, crotonaldehyde, methyl ethyl ketone, butyraldehyde, hydrogen cyanide, nitrous oxides, nitrosamines such as tobacco-specific nitrosamines, hydroquinone, resorcinol, catechol, phenol, cresols, tar, nicotine, carbon monoxide, butadienes, isoprene, acrylonitrile, benzene, toluene, and the like. Depending upon the particular component, the Hoffmann analyte may be reduced by at least 2%, such as at least 5%, such as at least 10%, such as at least 15%, and in some applications, by at least 20% based upon the total amount of the component per smoking article or cigarette.

**[0033]** Formaldehyde levels, for instance, may be reduced by at least 5%, such as at least 10%, or at least 15%. Aminonaphthalenes may be reduced by at least 3%, such as at least 5%. Nitrous oxides may be reduced by greater than 10%, such as greater than about 20%. Hydrogen cyanide has been found to be reduced by at least about 2%, such as at least by about 5%. Ammonia may be reduced by at least about 15%, such as at least about 20%, and, in one embodiment, by at least about 25%. Of particular advantage, all of the above reductions may occur without the alginate composition affecting the taste of the smoking article or substantially interfering with any of the properties of the wrapper.

**[0034]** In order to assist in describing and explaining the present invention in more detail, one embodiment of a smoking article made in accordance with the present invention is illustrated in FIGS. 1 and 2. The smoking article 10 includes a tobacco column 12 within a wrapper 14 made in accordance with the present invention. The smoking article 10 may include a filter 26. The filter 26 may be enclosed by a tipping paper that can also be used to attach the filter to the smoking article.

**[0035]** Generally, the wrapping paper 14 can be made from cellulosic fibers obtained, for instance, from flax, soft wood, or hard wood. In order to vary the properties of the paper as desired, various mixtures of cellulosic fibers can be used. The extent to which the fibers are refined can also be varied.

**[0036]** For most applications, the paper wrapper 14 contains a filler. The filler can be, for instance, calcium carbonate, magnesium oxide, or any other suitable material. The total filler loading added to the paper wrapper can be between about 10% to about 40% by weight.

**[0037]** The permeability of the paper wrapper 14 can generally be from about 10 Coresta units to about 200 Coresta units. In some applications, for instance, the permeability can be from about 15 Coresta units to about 110 Coresta units. In one particular embodiment, for instance, the permeability of the paper wrapper prior to applying the alginate composition can be from about 60 Coresta units to about 110 Coresta units, such as from about 80 Coresta units to about 100 Coresta units.

**[0038]** The basis weight of the wrapping paper 14 may be between about 15 gsm to about 60 gsm, and more particularly between about 18 gsm to about 40 gsm.

**[0039]** The wrapping paper 14 may be treated with a burn control additive, which may also serve as an ash conditioner. Such burn control additives can include, for instance, alkali metal salts, acetates, phosphate salts or mixtures thereof. A particularly preferred burn control additive is a mixture of potassium citrate and sodium citrate. The burn control additive can be added to the paper wrapper in an amount from about 0.3% to about 5% by weight, and more particularly from about 0.3% to about 2.5% by weight.

**[0040]** The paper wrapper **14** defines an outer circumferential surface **16** when wrapped around the tobacco column **12**. In accordance with the present invention, an alginate composition is incorporated into the paper wrapper **14** for reducing Hoffmann analytes contained in the mainstream smoke produced by the smoking article **10**. The alginate composition may be incorporated into the paper wrapper **14** using various methods and techniques. In fact, it is believed that the alginate composition may be incorporated into the paper wrapper at any stage during the production of the paper wrapper.

**[0041]** In one embodiment, for instance, an alginate composition may be combined with an aqueous slurry of fibers that is used to produce the paper wrapper **14**. The alginate composition may be combined with the aqueous suspension of fibers in an amount sufficient so that a desired amount of alginate remains in the paper once it is formed for reducing Hoffmann analytes. In general, any suitable alginate may be used in accordance with the present invention. The alginate may be, for instance, a sodium alginate or a potassium alginate. In other embodiments, an ammonium alginate, a propylene glycol alginate, and the like may be used. Further, it should be understood that mixtures of different types of alginates may be used.

**[0042]** Suitable salts and/or derivatives of alginic acid may be obtained, for instance, from ISP Corporation. Exemplary products include, for instance, KELGIN MV which is a granular refined sodium alginate having a mesh size of about 30. A 1% solution of KELGIN MV has a viscosity of about 400 centipoise at 25° C. as measured using a Brookfield LVF viscometer. A 2% solution of KELGIN MV has a viscosity of about 6000 centipoise at 25° C. as measured using a Brookfield LVF viscometer.

**[0043]** In addition to KELGIN MV, KELGIN LV may also be used. KELGIN LV has a lower viscosity than KELGIN MV.

**[0044]** Other commercially available alginates that may be used in accordance with the present invention include KELGIN LB, KELGIN RL, MANUCOL LD and MANUCOL LB, which are all also commercially available from the ISP Corporation. The above alginates generally have a viscosity of less than about 500 centipoise when contained in a 3% by weight aqueous solution at 25° C. For instance, the alginates can have a viscosity of less than about 250 centipoise at the above conditions, particularly less than 100 centipoise, and in one embodiment at a viscosity of about 20 to 60 centipoise.

**[0045]** In addition to combining an alginate composition with an aqueous suspension of fibers in forming the paper wrapper, in other embodiments, the alginate composition may be applied topically to the paper wrapper. For example, in one embodiment, the alginate composition can be applied to the paper wrapper as the paper wrapper is being formed. If the paper wrapper is made according to a wetlaid papermaking process, the alginate composition may be applied to the wrapper prior to the wrapper being dried or after the wrapper has been dried. For example, in one embodiment, the alginate composition may be applied to the paper wrapper using a size press during production of the paper wrapper. The size press, for instance, may comprise a bath in which the paper wrapper is dipped, a spray device, or a roll that is dipped into a bath containing an alginate composition for application to the paper wrapper.

**[0046]** In still other embodiments, the alginate composition may be applied to the paper wrapper in an offline process after the wrapper is formed. In this embodiment, for instance, the

alginate composition may be sprayed or printed onto the paper wrapper. Any suitable printing technique may be used including flexographic printing, offset rotogravure printing, and the like.

**[0047]** When topically applying the alginate composition to the paper wrapper, in one embodiment, lower viscosity alginate compositions may be used. For example, lower viscosity alginate compositions can be formed at higher solids content but yet at a low enough solution viscosity to permit the application of the composition to a paper wrapper using conventional printing and spraying techniques. For example, the solids content of an alginate solution can be greater than about 6%, particularly greater than about 10%, and more particularly from about 10% to about 20% by weight while still having a solution viscosity of greater than about 250 centipoise, particularly greater than about 500 centipoise, and more particularly greater than about 800 centipoise. For example, in one embodiment, the alginate composition that is applied to the paper wrapper may have a viscosity of greater than about 1000 centipoise at 25° C.

**[0048]** In general, alginate compositions that are topically applied to the paper wrapper can contain alginate and water. Although not necessary, other ingredients may also be included within the composition. For instance, in one embodiment, a filler can be contained within the composition. The filler can be, for instance, calcium carbonate, calcium chloride, calcium lactate, calcium gluconate, and the like. In addition to calcium compounds, other metal oxides can also be included.

**[0049]** In still other embodiments, the alginate composition can be combined with a burn promoter such as a citrate and/or MAP. The alginate composition can also contain other organic or inorganic type salts, such as sodium or potassium salts of acidic, malic, maleic acid, chloride, phosphate, and the like.

**[0050]** When the alginate composition is applied topically, in one embodiment, the alginate composition is applied so as to cover a substantial portion of the surface area of the paper wrapper. For example, in various embodiments, the alginate composition may be applied so as to cover at least 70%, such as at least 80%, such as at least 90%, and, in one embodiment, at least 95% of the surface area of the paper wrapper. The alginate composition may be applied as a continuous coating or as a discontinuous coating. When applied as a discontinuous coating, the alginate composition may be applied according to any suitable pattern as long as the desired amount of surface area of the paper wrapper is covered. Further, when using various printing techniques, such as rotogravure printing, the alginate composition is applied as small droplets that may leave untreated areas on the paper wrapper. For example, rotogravure printers include gravure cells which hold a small amount of the composition and which is released in a pattern either directly onto the paper wrapper or onto a rubber applicator roll. The pattern substantially covers the entire surface area of the paper wrapper but may leave small areas of untreated portions. These untreated portions may be desirable in some applications.

**[0051]** In one embodiment of the present invention, the alginate composition is applied only to the distal end of the smoking article. In particular, it is believed that certain Hoffmann analytes are produced during initial ignition and during the first few puffs taken from the smoking article. Thus, sufficient Hoffmann analyte reduction may occur if a single band is placed at the distal end of the paper wrapper when

placed on a smoking article. In this embodiment, for instance, the band may start substantially at the distal end of the paper wrapper and extend so as to cover at least about 30% of the surface area of the wrapper, such as at least about 50% of the surface area of the wrapper.

**[0052]** In contrast to when alginate compositions are used for reducing the ignition proclivity characteristics of a smoking article, alginate compositions applied according to the present invention can reduce Hoffmann analytes without substantially affecting any other properties of the paper wrapper. In fact, paper wrappers treated with an alginate composition according to the present invention may fail the Mock-Up Ignition Test and the Cigarette Extinction Test. Further, the alginate composition when applied according to the present invention should either have no substantial impact on the permeability of the wrapping paper or is used so that the permeability falls within desired limits for freeburning cigarettes.

**[0053]** In general, the alginate composition may be applied according to the present invention in amounts up to about 10% by weight. For example, the alginate composition may be applied in an amount from about 0.1% to about 8% by weight. The amount of the alginate composition applied to the paper wrapper will generally depend upon the desired results and various other factors. For example, in one embodiment, the alginate composition may be applied in an amount from about 0.25% to about 5% by weight, such as from about 0.75% to about 3% by weight. In other embodiments, however, greater amounts may be applied, such as from about 5% to about 8% by weight. In one embodiment, the permeability of the paper wrapper may be reduced by no more than about 50%, such as no more than about 40%, and, in one embodiment, by no more than 30% when the alginate composition is applied or otherwise incorporated into the wrapper. The permeability of the paper wrapper after being treated with the alginate composition, for instance, may be from about 25 Coresta to about 55 Coresta, such as from about 30 Coresta to about 50 Coresta. In one embodiment, for instance, the paper wrapper may have an initial permeability of greater than about 60 Coresta, such as greater than about 80 Coresta. Once treated with an alginate composition in accordance with the present invention, however, the paper wrapper may have a resulting permeability of from about 25 Coresta to about 55 Coresta, such as from about 30 Coresta to about 40 Coresta.

**[0054]** It should be understood that paper wrappers made according to the present invention may also contain discrete areas or bands that reduce the ignition proclivity characteristics of the smoking article. For instance, in one embodiment, an alginate composition may be applied according to the present invention so as to cover a substantial portion of the surface area of the paper wrapper. A film-forming composition, such as a cellulose composition or an alginate composition, may also be applied to the paper wrapper to form discrete areas or bands that reduce the ignition proclivity characteristics of the present invention. The bands or treated discrete areas may have a width so that oxygen is limited to the burning coal for a sufficient length or period of time to extinguish the coal if the smoking article were left on an adjacent surface. For instance, when applied in the form of bands, the bands may have a width of at least about 3 mm, such as from about 4 mm to about 10 mm. The bands can then be spaced apart so as to have a band spacing of between 5 and 50 mm. Within the treated discrete areas or bands, the paper wrapper may have a Burn Mode Index, as described in U.S.

Pat. No. 4,739,775, of generally less than about  $8 \text{ cm}^{-1}$ , and particularly from 0 to about  $5 \text{ cm}^{-1}$ . For instance, in one embodiment, the Burn Mode Index of the treated areas can be from about  $1 \text{ cm}^{-1}$  to about  $3 \text{ cm}^{-1}$ .

**[0055]** The treated discrete areas used for reducing the ignition proclivity characteristics of the smoking article can be formed from various materials. In particular, any suitable film-forming material may be used, such as an alginate, guar gum, pectin, polyvinyl alcohol, cellulosic materials, cellulose derivatives such as ethyl cellulose, methyl cellulose, carboxymethyl cellulose, starch, starch derivatives, mixtures thereof, and the like.

**[0056]** The present invention may be better understood with reference to the following example.

#### Example

**[0057]** The following example is provided for exemplary purposes in order to demonstrate that an alginate composition applied to a paper wrapper can reduce Hoffmann analytes in mainstream smoke generated by a smoking article incorporating the wrapper.

**[0058]** A cigarette was constructed that contained a paper wrapper having a basis weight of 28 and a permeability of 80 CORESTA. The paper wrapper included bands that were 6 mm wide and spaced 20 mm apart along the length of the wrapper. The bands were formed from an alginate composition. The alginate composition contained KELGIN LP alginate obtained from the ISP Corporation. The bands were applied to the wrapper in order to reduce the ignition proclivity characteristics of the cigarette.

**[0059]** The cigarette was placed in a smoking machine that was set to have a puff volume of 35 mL at 60-second intervals. The mainstream smoke was collected and tested for various Hoffmann analytes. A control cigarette was similarly tested. The control cigarette contained a similar paper wrapper, but was not treated with alginate composition bands. The following results were obtained:

Tobacco Constituent	Sample ID Unit	Control Average	Sample No. 1 Average
Ammonia	( $\mu\text{g}/\text{cig}$ )	19.3	15.2
1-aminonaphthalene	( $\text{ng}/\text{cig}$ )	21.6	19.1
2-aminonaphthalene	( $\text{ng}/\text{cig}$ )	13.1	11.7
3-aminobiphenyl	( $\text{ng}/\text{cig}$ )	2.81	2.57
4-aminobiphenyl	( $\text{ng}/\text{cig}$ )	2.36	2.24
Benzo[a]pyrene	( $\text{ng}/\text{cig}$ )	7.48	6.48
Formaldehyde	( $\mu\text{g}/\text{cig}$ )	27.7	24.6
Acetaldehyde	( $\mu\text{g}/\text{cig}$ )	490	457
Acetone	( $\mu\text{g}/\text{cig}$ )	222	216
Acrolein	( $\mu\text{g}/\text{cig}$ )	54.8	47.7
Propionaldehyde	( $\mu\text{g}/\text{cig}$ )	43.5	40.6
Crotonaldehyde	( $\mu\text{g}/\text{cig}$ )	15.3	13.4
Methyl ethyl ketone	( $\mu\text{g}/\text{cig}$ )	54.7	53.6
Butyraldehyde	( $\mu\text{g}/\text{cig}$ )	28.3	25.3
Hydrogen Cyanide	( $\mu\text{g}/\text{cig}$ )	113	107
NO	( $\mu\text{g}/\text{cig}$ )	188	143
NOx	( $\mu\text{g}/\text{cig}$ )	191	145
Nitrosornicotine (NNN)	( $\text{ng}/\text{cig}$ )	112	93.5
Nitrosoanatabine (NAT)	( $\text{ng}/\text{cig}$ )	115	90.4
Nitrosoanabasine (NAB)	( $\text{ng}/\text{cig}$ )	15.9	12.5
4-(N-nitrosomethylamino)-1-(3-pyridyl)-1-butanone (NNK)	( $\text{ng}/\text{cig}$ )	74.5	60.1
Pyridine	( $\mu\text{g}/\text{cig}$ )	13.3	13.1
Quinoline	( $\mu\text{g}/\text{cig}$ )	0.373	0.333
Hydroquinone	( $\mu\text{g}/\text{cig}$ )	49.1	47.4
Resorcinol	( $\mu\text{g}/\text{cig}$ )	1.18	1.10

-continued

Tobacco Constituent	Sample ID Unit	Control Average	Sample No. 1 Average
Catechol	( $\mu\text{g}/\text{cig}$ )	49.1	49.3
Phenol	( $\mu\text{g}/\text{cig}$ )	12.9	12.6
m + p-cresols	( $\mu\text{g}/\text{cig}$ )	9.34	9.23
o-cresol	( $\mu\text{g}/\text{cig}$ )	3.29	3.25
Carbon Monoxide	( $\text{mg}/\text{cig}$ )	10.8	10.4
1,3-butadiene	( $\mu\text{g}/\text{cig}$ )	40.1	35.3
Isoprene	( $\mu\text{g}/\text{cig}$ )	423	364
Acrylonitrile	( $\mu\text{g}/\text{cig}$ )	9.64	7.88
Benzene	( $\mu\text{g}/\text{cig}$ )	40.2	36.4
Toluene	( $\mu\text{g}/\text{cig}$ )	76.7	67.1
Styrene	( $\mu\text{g}/\text{cig}$ )	8.85	8.87

**[0060]** As shown above, the amount of Hoffmann analytes contained in the mainstream smoke of Sample No. 1 was significantly lower than the amount of Hoffmann analytes contained in the mainstream smoke of the Control. The above test was completed simply to demonstrate that an alginate composition has the ability to reduce Hoffmann analytes. The present inventors believe that further reductions in certain of the Hoffmann analytes may result if the alginate composition is applied differently than in bands according to Sample No. 1.

**[0061]** These and other modifications and variations to the present invention may be practiced by those of ordinary skill in the art, without departing from the spirit and scope of the present invention, which is more particularly set forth in the appended claims. In addition, it should be understood that aspects of the various embodiments may be interchanged both in whole or in part. Furthermore, those of ordinary skill in the art will appreciate that the foregoing description is by way of example only, and is not intended to limit the invention so further described in such appended claims.

What is claimed:

1. A process for producing a wrapper for a smoking article comprising:

producing a wetlaid paper wrapper from an aqueous suspension of fibers;

applying a chemical composition to the paper wrapper prior to drying the wrapper, the chemical composition having a viscosity of greater than 800 centipoise and covering at least 70% of the surface area of the wrapper;

drying the paper wrapper, the chemical composition being present in the dried paper wrapper in an amount from about 0.1% to about 8% by weight; and

applying a film-forming composition or a cellulose composition to the dried paper wrapper to form a treated discrete area on the paper wrapper, the treated discrete area having a width extending in a longitudinal direction of from about 3 mm to about 10 mm.

2. A process as defined in claim 1, wherein the chemical composition comprises an alginate.

3. A process as defined in claim 1, wherein the chemical composition further comprises a burn promoting agent.

4. A process as defined in claim 1, wherein the permeability of the dried paper wrapper is from about 25 Coresta to about 55 Coresta prior to forming the treated discrete area.

5. A process as defined in claim 3, wherein the burn promoting agent comprises a citrate.

6. A process as defined in claim 2, wherein the chemical composition further comprises a burn promoting agent.

7. A process as defined in claim 1, wherein the cellulose composition is applied to the dried paper wrapper for forming the treated discrete area.

8. A process as defined in claim 1, wherein the chemical composition is present on the dried paper wrapper in an amount from about 0.75% to about 5% by weight.

9. A process as defined in claim 1, wherein the film-forming composition is applied to the dried paper wrapper to form the treated discrete area, the film-forming composition comprising an alginate.

10. A process as defined in claim 1, wherein the film-forming composition is applied to the dried paper wrapper to form the treated discrete area, the film-forming composition comprising guar gum, pectin, polyvinyl alcohol, a cellulose derivative, a starch, a starch derivative, or mixtures thereof.

11. A process as defined in claim 2, wherein the film-forming composition is applied to the dried paper wrapper to form the treated discrete area, the film-forming composition comprising an alginate.

12. A process as defined in claim 2, wherein the film-forming composition is applied to the dried paper wrapper to form the treated discrete area, the film-forming composition comprising guar gum, pectin, polyvinyl alcohol, a cellulose derivative, a starch, a starch derivative, or mixtures thereof.

13. A process as defined in claim 2, wherein the film-forming composition is applied to the dried paper wrapper to form the treated discrete area, the film-forming composition comprising a starch or a starch derivative.

14. A process as defined in claim 2, wherein the film-forming composition is applied to the dried paper wrapper to form the treated discrete area, the film-forming composition comprising a cellulose derivative.

15. A process as defined in claim 1, wherein the dried paper wrapper has a basis weight of from about 15 gsm to about 60 gsm.

16. A process as defined in claim 1, wherein the chemical composition is applied to the paper wrapper by a size press.

17. A process as defined in claim 1, wherein the chemical composition is applied to the paper wrapper by contacting the paper wrapper with a roll that is dipped into a bath containing the chemical composition.

18. A process as defined in claim 1, wherein the chemical composition is applied to the paper wrapper by dipping the paper wrapper in a bath comprising the chemical composition.

19. A wrapper for a smoking article comprising:

a paper wrapper comprising cellulosic fibers and a filler, the wrapper having a length in a longitudinal direction and a width in a lateral direction, the wrapper also having a surface area;

a chemical composition covering at least 70% of the surface area of the wrapper, the chemical composition being present on the wrapper in an amount from about 0.7% to about 8% by weight; and

a treated discrete area located on the wrapper containing the chemical composition, the treated discrete area comprising a band that extends in the lateral direction, the band having a width of from about 3 mm to about 10 mm, the treated discrete area comprising a film-forming composition or a cellulose composition, the wrapper having a permeability outside of the treated discrete area where the chemical composition is located being from about 25 Coresta to about 55 Coresta.



**20.** A wrapper as defined in claim **19**, wherein the chemical composition comprises an alginate.

**21.** A wrapper as defined in claim **19**, wherein the treated discrete area comprises the cellulose composition.

**22.** A wrapper as defined in claim **20**, wherein the treated discrete area comprises the cellulose composition.

**23.** A wrapper as defined in claim **19**, wherein the treated discrete area comprises the film-forming composition, the film-forming composition comprising an alginate.

**24.** A wrapper as defined in claim **20**, wherein the treated discrete area comprises the film-forming composition, the film-forming composition comprising an alginate.

**25.** A wrapper as defined in claim **19**, wherein the treated discrete area comprises the film-forming composition, the film-forming composition comprising guar gum, pectin, polyvinyl alcohol, a cellulose derivative, a starch, a starch derivative, or mixtures thereof.

**26.** A wrapper as defined in claim **20**, wherein the treated discrete area comprises the film-forming composition, the film-forming composition comprising guar gum, pectin, polyvinyl alcohol, a cellulose derivative, a starch, a starch derivative, or mixtures thereof.

**27.** A wrapper as defined in claim **19**, wherein the treated discrete area comprises the film-forming composition, the film-forming composition comprising a starch or a starch derivative.

**28.** A wrapper as defined in claim **20**, wherein the treated discrete area comprises the film-forming composition, the film-forming composition comprising a starch or a starch derivative.

**29.** A wrapper as defined in claim **19**, wherein the treated discrete area comprises the film-forming composition, the film-forming composition comprising a cellulose derivative.

**30.** A wrapper as defined in claim **20**, wherein the treated discrete area comprises the film-forming composition, the film-forming composition comprising a cellulose derivative.

**31.** A wrapper as defined in claim **19**, wherein the chemical composition is present on the wrapper in combination with a burn promoting agent.

**32.** A wrapper as defined in claim **20**, wherein the chemical composition is present on the wrapper in combination with a burn promoting agent.

**33.** A wrapper as defined in claim **31**, wherein the burn promoting agent comprises a citrate.

**34.** A wrapper as defined in claim **32**, wherein the burn promoting agent comprises a citrate.

**35.** A wrapper as defined in claim **24**, wherein the chemical composition is present on the wrapper in combination with a burn promoting agent.

**36.** A wrapper as defined in claim **26**, wherein the chemical composition is present on the wrapper in combination with a burn promoting agent.

**37.** A wrapper as defined in claim **28**, wherein the chemical composition is present on the wrapper in combination with a burn promoting agent.

**38.** A wrapper as defined in claim **30**, wherein the chemical composition is present on the wrapper in combination with a burn promoting agent.

\* \* \* \* \*