

April 27, 1965

E. H. JOHNSON

3,180,246

AIR CONTROL DEVICE SUCH AS A DIFFUSER OR THE LIKE

Filed Oct. 31, 1962

2 Sheets-Sheet 1

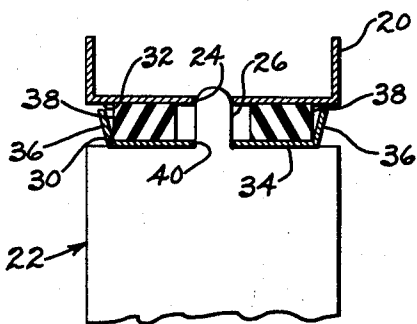
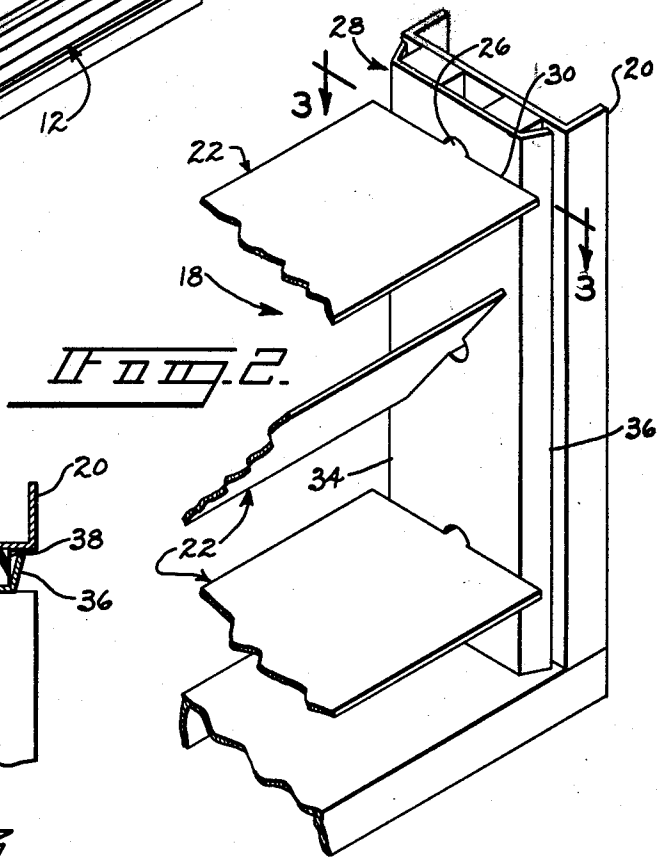
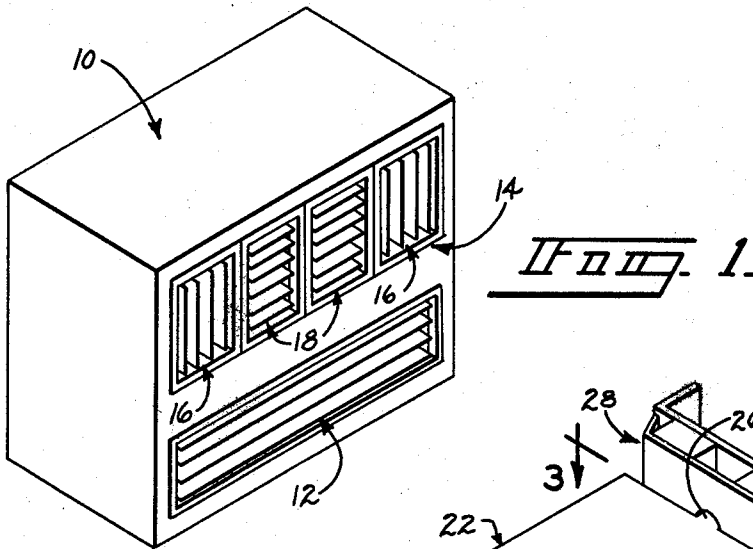

INVENTOR
EDWARD H. JOHNSON
BY
Olwen + Olwen
ATTORNEYS

April 27, 1965

E. H. JOHNSON

3,180,246

AIR CONTROL DEVICE SUCH AS A DIFFUSER OR THE LIKE

Filed Oct. 31, 1962

2 Sheets-Sheet 2

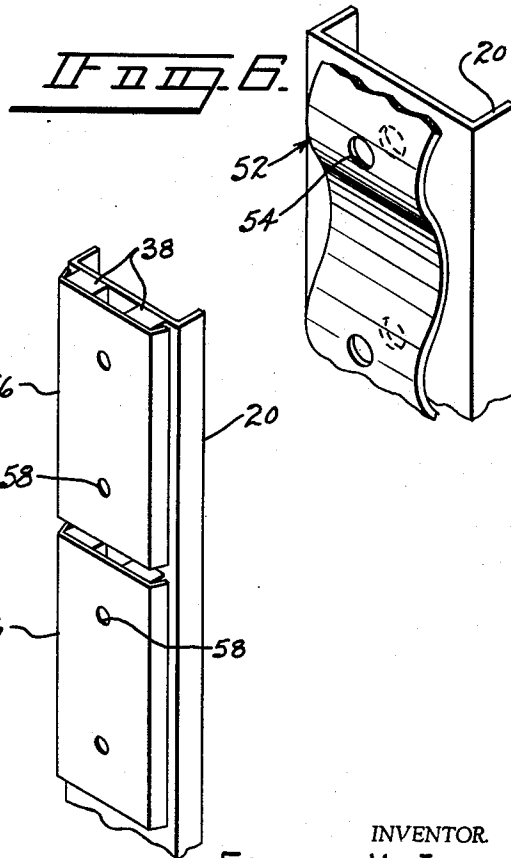
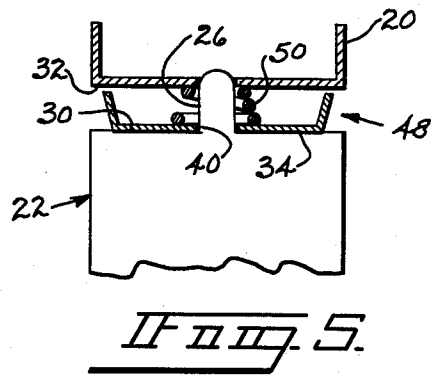
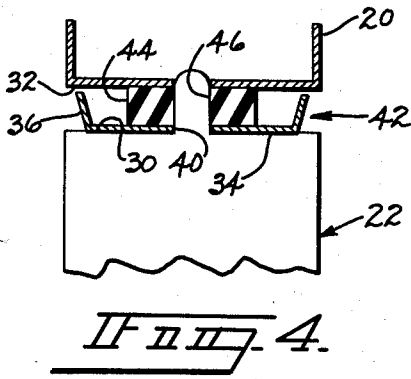

INVENTOR
EDWARD H. JOHNSON

BY

Owen & Owen
ATTORNEYS

1

2

3,180,246

**AIR CONTROL DEVICE SUCH AS A
DIFFUSER OR THE LIKE**

Edward H. Johnson, Maumee, Ohio, assignor to The American Warming & Ventilating Inc., Toledo, Ohio, a corporation of Ohio

Filed Oct. 31, 1962, Ser. No. 234,306

3 Claims. (Cl. 98—40)

This invention relates to an air control device such as a diffuser or the like with adjustable diffuser blades and more particularly to a frictional device for holding individual diffuser blades in given positions.

Diffusers are commonly used on units for conditioning air, by way of example, for directing the outlet air in a desired direction. The blades usually are turned by hand to any of a wide variety of individual positions with the variety being increased by the fact that some blades are mounted horizontally and some vertically. However, the blades can be motor-operated, particularly when they are connected together. Various ways have been devised for holding the blades in position, but these have had various disadvantages, such as being too expensive, being effective only for particular types of blades or installations, or lacking sufficient holding power, whereby the blades tend to move out of position during operation of the unit in which they are installed.

The present invention relates to an improved frictional device for diffuser blades which is less expensive than many heretofore known, has excellent holding power for the blades, and is suitable for almost any diffuser installation.

It is, therefore, a principal object of the invention to provide a diffuser or the like with an improved frictional device having the advantages outlined above.

Other objects and advantages of the invention will be apparent from the following detailed description of a preferred embodiment thereof, reference being made to the accompanying drawing, in which:

FIG. 1 is a view in perspective of an air conditioning unit employing diffusers embodying the invention;

FIG. 2 is an enlarged, fragmentary view in perspective of a diffuser with a frictional device according to the invention;

FIG. 3 is a view in horizontal cross section, taken along the line 3—3 of FIG. 2;

FIGS. 4 and 5 are views similar to FIG. 3 of modified frictional devices;

FIG. 6 is a view in perspective of another modification of a frictional device according to the invention; and

FIG. 7 is a view similar to FIG. 6 of another modified frictional device.

Referring to the drawing, and more particularly to FIG. 1, a unit for conditioning air is indicated at 10 and includes an air inlet 12 and an air outlet 14 comprising diffusers 16 with vertical blades and diffusers 18 with horizontal blades. The combination of horizontal and vertical blades can direct the air in almost any conceivable manner to achieve a desired effect. Further, horizontal blades can be placed in front of or behind the vertical ones.

The diffuser 18, shown greatly enlarged in FIG. 2, includes a side frame member 20 which rotatably carries diffuser blades 22 by means of openings 24 in the frame member through which axles or trunnions 26 of the blades 22 are inserted. The blades 22 are of thin material, plastic or sheet metal, for example, but are sufficiently stiff to prevent vibration as air flows past them. To obtain maximum variation in the direction of air flow, each of the blades 22 preferably is individually adjust-

able by hand to any of a wide variety of positions, some being shown in FIG. 2.

To retain the blades 22 in their positions, a frictional device indicated at 28 is interposed between ends 30 of the blades 22 and an inner surface 32 of the frame member 20. The frictional device 28 includes a long pressure plate 34 having inturned edge flanges 36 which are spaced from the surface 32 of the frame member 20 and serve to provide a smooth appearance for the diffuser 18 as well as to restrict entry of dirt behind the plate 34. The plate 34 preferably is made of metal if the blades 22 are of metal and can be either metal or plastic if the blades 22 are of plastic. The plate 34 is urged against the ends 30 of the blades 22 by suitable resilient means interposed between the plate 34 and the surface 32 of the frame member 20.

As shown in FIG. 3, the resilient means comprises a pair of strips 38 of a resilient material such as rubber or certain cellular plastic materials. These strips extend longitudinally of the frame member 20 on each side of the trunnion openings 24 therein and also on each side of trunnion openings 40 in the pressure plate 34. If desired, the strips 38 can be adhered to the frame member initially by a suitable adhesive or can be similarly adhered to the plate 34 to facilitate proper positioning of them. The strips 38 are of a sufficient thickness that they tend to be squeezed between the frame member 20 and the plate 34 and, in turn, urge the plate 34 against the ends 30 of the blades 22. The other ends 30 of the blades 22 bear against either the frame member at the opposite edge of the diffuser or against a similar pressure plate at that end. Whether one or two of the frictional devices 28 are employed depends on such factors as the length and width of the blades, the weight of them, and the velocity of the air flowing past them. In any case, once the blades 22 are placed in a predetermined position, they remain securely in that position by means of the frictional device 28.

Rather than employing a pair of resilient strips 38, a modified frictional device 42 of FIG. 4 employs a single resilient strip 44 in which holes 46 are made to receive the trunnions 26. The strip 44 can be assembled slightly more easily than the two strips 38 but requires more material.

In place of the strips 38 or 44, a modified frictional device 48 of FIG. 5 employs coil springs 50 around each of the trunnions 26 of the blade 22 with the spring 50 being maintained under compression between the frame member 20 and the pressure plate 34 to urge the plate against the end 30 of the blade 22. The spring 50 thereby functions in the same manner as the strips 38 and 44. Other types of springs can also be used.

Rather than employing separate resilient means, the pressure plate itself can be sufficiently resilient and curved to provide pressure against the blade ends. In FIG. 6, a curved pressure plate 52 is shown curved into an undulating configuration so that portions between trunnion openings 54 contact the frame member and intermediate portions adjacent the openings 54 contact the ends of the blades.

In some instances, the frame members 20 of the diffuser 18 may not always be exactly parallel or straight so that the distance between them will vary and different pressure will tend to be placed upon the ends 30 of the blades 22. This difference can be overcome if the pressure plate 34 is sufficiently resilient and the resilient means 38, 44 or 50 behind it is sufficiently yieldable to compensate for the variation in distance. While the latter can be readily accomplished, the pressure plate 34 may not always be sufficiently resilient to accommodate more extreme variations in the spacing between the frame members 20. Hence, in some instances, it may be desired to

3

4

employ a plurality of pressure plates 56, as shown in FIG. 7, each of which can move laterally independently of the adjacent one to accommodate any difference in spacing. The pressure plates 56 have openings 58 for the trunnions 26 with each of the plates 56 preferably being employed with at least two of the blades 22. The plates 56 are urged against the ends of the blades 22 by any of the resilient means previously discussed, such as the strips 38, as shown.

While the frictional device has been described in connection with the diffuser 18, it is used equally well with the diffuser 16. Further, it is not essential that all of the blades have frictional devices. In some instances, some or all of the blades may be fixed or may be linked together for simultaneous movement, as in a damper, in which case only one or a few frictional devices are necessary.

Various modifications of the above described embodiments of the invention will be apparent to those skilled in the art, and it is to be understood that such modifications can be made without departing from the scope of the invention, if they are within the spirit and tenor of the accompanying claims.

I claim:

1. An air control device such as a diffuser or the like comprising a frame member having a plurality of substantially equally spaced openings therealong, a plurality of blades having trunnions rotatably received in said frame member openings, a pressure plate interposed between said frame member and ends of said blades, and a resilient strip between said frame member and said blade and extending substantially over the length of said plate

to urge said pressure plate toward the ends of said blades.

2. An air control device such as a diffuser or the like comprising a frame member having a plurality of equally spaced openings extending over at least a substantial portion of the length thereof, a plurality of diffuser blades having trunnions rotatably received in said frame openings, a pressure plate interposed between said frame member and ends of said blades and having a plurality of openings therein through which said trunnions extend, said plate extending substantially over the length of said frame member and having side flanges extending longitudinally thereof toward said frame member, and resilient means interposed between said frame member and said pressure plate and located on opposite sides of said trunnions to urge said pressure plate toward the adjacent ends of said blades and to frictionally engage at least a substantial portion of said ends to restrain movement of said blades.

3. A device according to claim 2 wherein said pressure plate is segmented into a plurality of plates with each segmented plate capable of movement independently of the other segmented plates to accommodate unevenness in said frame member.

References Cited by the Examiner

UNITED STATES PATENTS

2,137,426	11/38	Thompson	98—121
2,600,934	6/52	Spieth	98—110
3,055,284	9/62	Pellegrini	98—110

ROBERT A. O'LEARY, *Primary Examiner.*