

(12) STANDARD PATENT
(19) AUSTRALIAN PATENT OFFICE

(11) Application No. **AU 2002241737 B2**

(54) Title
Instrument panel system with hidden airbag door

(51) International Patent Classification(s)
B60K 37/00 (2006.01) **B60R 21/215** (2006.01)
B29C 43/02 (2006.01) **B29C 37/00** (2006.01)
B29C 43/18 (2006.01) **B29L 31/58** (2006.01)
B60R 21/20 (2006.01)

(21) Application No: **2002241737** (22) Date of Filing: **2001.10.23**

(87) WIPO No: **WO03/035435**

(43) Publication Date: **2003.05.06**

(43) Publication Journal Date: **2003.07.03**

(44) Accepted Journal Date: **2008.01.31**

(71) Applicant(s)
General Electric Company;Frank Litjens;Lahoussaine Ghrit

(72) Inventor(s)
Litjens, Frank;Boutghrit, Lahoussaine

(74) Agent / Attorney
Phillips Ormonde & Fitzpatrick, Level 22 367 Collins Street, Melbourne, VIC, 3000

(56) Related Art
US 5641554
US 6042140
US 5839752
US 5845929

(12) INTERNATIONAL APPLICATION PUBLISHED UNDER THE PATENT COOPERATION TREATY (PCT)

(19) World Intellectual Property Organization
International Bureau



(43) International Publication Date
1 May 2003 (01.05.2003)

PCT

(10) International Publication Number
WO 03/035435 A1

(51) International Patent Classification⁷: B60R 21/20

(21) International Application Number: PCT/US01/50789

(22) International Filing Date: 23 October 2001 (23.10.2001)

(25) Filing Language: English

(26) Publication Language: English

(71) Applicant (for all designated States except US): GENERAL ELECTRIC COMPANY [US/US]; One River Road, Schenectady, NY 11901 (US).

(71) Applicants and

(72) Inventors: LITJENS, Frank [NL/NL]; Burgermeester Passtoorsstraat 4, NL-4835 KG Breda (NL). BOUTGHRIT, Lahoussaine [NL/NL]; Carinastraat 6, NL-2624 BJ Bergen op Zoom (NL).

(74) Agents: BEULICK, John, S. et al.; Armstrong Teasdale LLP, Suite 2600, One Metropolitan Square, St. Louis, MO 63012 (US).

(81) Designated States (national): AE, AG, AL, AM, AT, AU, AZ, BA, BB, BG, BR, BY, BZ, CA, CH, CN, CO, CR, CU, CZ, DE, DK, DM, DZ, EC, EE, ES, FI, GB, GD, GE, GI, GM, HR, HU, ID, IL, IN, IS, JP, KE, KG, KP, KR, KZ, LC, LK, LR, LS, LT, LU, LV, MA, MD, MG, MK, MN, MW, MX, MZ, NO, NZ, PH, PL, PT, RO, RU, SD, SE, SG, SI, SK, SL, TJ, TM, TR, TT, TZ, UA, UG, US, UZ, VN, YU, ZA, ZW.

(84) Designated States (regional): ARIPO patent (GH, GM, KE, LS, MW, MZ, SD, SL, SZ, TZ, UG, ZW), Eurasian patent (AM, AZ, BY, KG, KZ, MD, RU, TJ, TM), European patent (AT, BE, CH, CY, DE, DK, ES, FI, FR, GB, GR, IE, IT, LU, MC, NL, PT, SE, TR), OAPI patent (BF, BJ, CF, CG, CI, CM, GA, GN, GQ, GW, ML, MR, NE, SN, TD, TG).

Published:

— with international search report

For two-letter codes and other abbreviations, refer to the "Guidance Notes on Codes and Abbreviations" appearing at the beginning of each regular issue of the PCT Gazette.

(54) Title: INSTRUMENT PANEL SYSTEM WITH HIDDEN AIRBAG DOOR

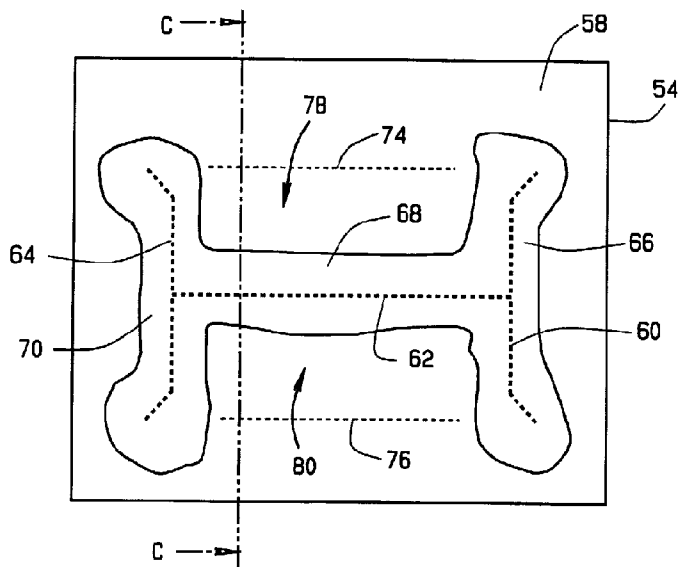

(57) Abstract: An instrument panel (12) includes a thermoplastic base substrate (54), with at least one tear seam notch (60) pressed into a first surface (56) of the base substrate. At least one consolidated area (66) is pressed into a second surface (58) of the base substrate. The at least one consolidated area is aligned with the at least one tear seam notch. The instrument panel further includes at least one hinge area (74). Each hinge area is an area of low consolidation where a thickness of the base substrate at the low consolidation area is greater than a thickness of the base substrate at the consolidation area. The at least one tear seam notch and the at least one hinge area define at least one airbag door (78).



WO 03/035435 A1

INSTRUMENT PANEL SYSTEM WITH HIDDEN
AIRBAG DOOR

BACKGROUND OF THE INVENTION

[0001] This invention relates generally to instrument panel assemblies, and more particularly to an instrument panel having a hidden airbag door.

[0002] Known instrument panel assemblies include a beam structure and at least one decorative instrument panel attached to the beam structure. Some of the decorative panels act as knee bolsters to protect the knees of vehicle occupants in the event of an impact. An instrument panel assembly is mounted inside the passenger compartment of an automobile with the beam structure attached to the automobile body, typically to the A-pillar. Known instrument panel beam structures are fabricated from steel or plastic.

[0003] A number of vehicle systems are housed within the instrument pane assembly, for example, the heating, ventilating, and air conditioning (HVAC) system, and the airbag system(s). To permit deployment of the airbag, the instrument panel includes a airbag opening covered by an airbag door. The placement of a door in the middle of a smooth surfaced instrument panel is considered as aesthetically unacceptable because the door destroys the clean aesthetic lines of an instrument panel. The deployment of the airbag forces the door open to permit the airbag to exit through the opening in the instrument panel. Typically, the door is fabricated from metal and is sometimes bent from the force of the airbag deployment. The bent airbag door does not close after the airbag deflates and could pose a hazard to the occupants in the event of a secondary impact of the occupant with the instrument panel.

[0004] Johnson Controls, Inc. has produced an instrument panel having a hidden airbag door. The molded base substrate is covered with a semi-rigid foam and a cover material. The underside of the instrument panel base substrate is scored with a laser to create a deployment seam in the shape of a door. A separate

metal hinge piece is molded into the back of the door and the underside of the base substrate to permit the door to pivot open during airbag deployment. The force of the airbag deployment forces the deployment seam to separate permitting the door to be forced through the foam layer and the cover layer of the instrument panel into an open position so the airbag can exit the instrument panel. The underside of the cover layer is scored to facilitate the door breaking through the cover. The laser cutting operation and the multiple components of the airbag door increases complexity of fabrication and assembly which increases fabrication time and increases labor costs.

[0004a] A reference herein to a patent document or other matter which is given as prior art is not to be taken as an admission that that document or matter was known or that the information it contains was part of the common general knowledge as at the priority date of any of the claims.

BRIEF DESCRIPTION OF THE INVENTION

[0005] According to an aspect of the present invention, there is provided an instrument panel including:

- a thermoplastic base substrate having a first surface and a second surface;
- at least one tear seam notch pressed into said first surface of said base substrate;
- at least one consolidated area pressed into said second surface of said base substrate, said at least one consolidated area aligned with said at least one tear seam notch;
- at least one hinge area including an area of low consolidation wherein a thickness of said base substrate at said low consolidation area is greater than a thickness of said base substrate at said at least one consolidated area, said at least one tear seam notch and said at least one hinge area defining at least one airbag door, wherein a width of said at least one consolidated area is equal to or greater than at least one tear seam notch.

[0006] According to another aspect of the present invention, there is provided an instrument panel system including an instrument panel and an airbag, said air bag positioned adjacent said instrument panel, said instrument panel including:

a thermoplastic base substrate having a first surface and a second surface, said air bag positioned adjacent said second surface of said base substrate;

5 at least one tear seam notch pressed into said first surface of said base substrate;

at least one consolidated area pressed into said second surface of said base substrate, said at least one consolidated area aligned with said at least one tear seam notch;

10 at least one hinge area including an area of low consolidation wherein a thickness of said base substrate at said low consolidation area is greater than a thickness of said base substrate at said at least one consolidated area, said at least one tear seam notch and said at least one hinge area defining at least one airbag door, said tear seam notch configured to open when said airbag deploys permitting said airbag to deploy through said instrument panel, wherein a width of said at least one consolidated
15 area is equal to or greater than at least one tear seam notch.

[0007] According to yet another aspect of the present invention, there is provided an instrument panel including:

20 a thermoplastic base substrate having a first surface and a second surface;
an intermediate layer adjacent said first surface of said base substrate, said intermediate layer including a resilient material;

an outer layer adjacent said intermediate layer;
25 at least one airbag door defined by at least one tear seam notch pressed into said base substrate and at least one hinge area including an area of low consolidation in said base substrate, said at least one airbag door not visible through said outer layer before an airbag deployment causes said at least one airbag door to open; and

at least one consolidated area pressed into said second surface of said base substrate, said at least one consolidated area aligned with said at least one tear seam notch.

30

3a

[0008] According to yet another aspect of the present invention, there is provided a method of producing an instrument panel system including an instrument panel and an airbag, said method including press molding a thermoplastic base substrate having a first surface and a second surface into a predetermined shape of the instrument panel, wherein press molding the base substrate includes:

pressing at least one tear seam notch into the base substrate;

pressing at least one consolidated area into the second surface of the base substrate, the at least one consolidated area aligned with the at least one tear seam notch;

pressing at least one hinge area into the second surface of the base substrate, each hinge area including an area of low consolidation wherein a thickness of the base substrate at the low consolidation area is greater than the thickness of the base substrate at the at least one consolidated area, the at least one tear seam notch and the at least one hinge area defining at least one airbag door, wherein a width of said at least one consolidated area is equal to or greater than at least one tear seam notch.

BRIEF DESCRIPTION OF THE DRAWINGS

[0009] Figure 1 is a perspective view of an instrument panel assembly in accordance with an embodiment of the present invention.

[0010] Figure 2 is a top schematic view of a portion of the instrument panel base substrate showing an H-shaped tear seam notch pattern.

[0011] Figure 3 is a bottom schematic view of the portion of the instrument panel base substrate shown in Figure 2.

[0012] Figure 4 is a cross sectional schematic view through line C-C of Figure 3.

[0013] Figure 5 is a cross sectional schematic view of the instrument panel through line C-C of Figure 3 showing an intermediate layer and a cover layer.

[0014] Figure 6 is a top schematic view of a portion of the instrument panel base substrate showing a double Y-shaped tear seam notch pattern.

[0015] Figure 7 is a top schematic view of a portion of the instrument panel base substrate showing a U-shaped tear seam notch pattern.

DETAILED DESCRIPTION OF THE INVENTION

[0016] An instrument panel system that includes an instrument panel with a hidden airbag door is described below in more detail. The airbag door is not visible to vehicle occupants before deployment of the airbag. The hidden airbag door opens by the force of the airbag deploying and permits the airbag to exit the instrument panel and enter the passenger compartment of the vehicle without secondary operations to the system. The opened airbag door includes smooth surfaces without sharp and/or hard edges to avoid vehicle occupant injuries. Further, the airbag door closes after the airbag deflates.

[0017] Referring to the drawings, Figure 1 is an exploded perspective view of an instrument panel assembly 10 in accordance with an exemplary embodiment of the present invention. Instrument panel assembly 10 includes an instrument panel 12 having duct outlet openings 14, 16, 18, and 20. Vent grills 22, 24, 26, and 28 are sized to mate with openings 14, 16, 18, and 20 respectively. An instrument cluster 30 and a cluster trim plate 32 are coupled to instrument panel 12. Cluster trim plate 32 includes vent grills 34 and 36. A driver side knee bolster 38 and a glove box surround 40 are coupled to instrument panel 12. A glove box 42 attaches to a glove box hinge portion 44 of glove box surround 40. The combination of glove box surround 40 and glove box 42 act as a passenger knee bolster. A center bezel 46 is coupled to driver side knee bolster 38 and glove box surround 40. A fuse access door 48 covers a fuse access opening 50 in glove box surround 40. An airbag module 52 is mounted adjacent instrument panel 12.

[0018] Figure 2 is a top schematic view of a portion of a base substrate 54 of instrument panel 10, Figure 3 is a bottom schematic view of the portion of instrument panel base substrate 54, and Figure 4 is a cross sectional schematic view of base substrate 54 through line C-C. Referring to Figures 2-4, base substrate 54 includes an upper surface 56 (Figure 2) and a lower surface 58 (Figure 3). When instrument panel 12 is installed in a vehicle, upper surface 56 faces the passenger compartment and lower surface 58 faces the inside of instrument panel assembly 10. Base substrate 54 includes tear seam notches 60, 62, and 64 that, in this exemplary embodiment, form a substantially H-shaped pattern. Tear seam notches 60, 62, and 64 are pressed into upper surface 56 when base substrate 54 is formed into a predetermined shape of instrument panel 12 in a press molding operation. A press molding operation includes pressing a sheet of thermoplastic material between an upper and lower die having the desired shape of the final part. The pressing operation is typically performed in conjunction with applied heat. A press molding operation using heat is sometimes referred to as thermoforming. In this exemplary embodiment, tear seam notches 60, 62, and 64 have a 90 degree V-shape. In other embodiments tear seam notches 60, 62, and 64 can have other cross sectional shapes, for example, 45 degree V-shape, U-shape, conical-shaped, spherical-shaped, and box-shaped. The thickness of base substrate 54 at each tear seam notch 60, 62, and 64 is about 0.5 to about 1.0 millimeter (mm). In other embodiments the thickness of base substrate at each tear seam notch 60, 62, and 64 can be higher than 1.0 mm or lower than 0.5 mm. Higher than 1.0 millimeter thickness requires greater force to tear the seams, and lower than 0.5 millimeter thickness requires less force to tear the seams. However, thickness significantly less than 0.5 millimeter can effect the integrity of instrument panel 12.

[0019] Base substrate 54 can be can be formed from one of many thermoplastic and fiber composites materials, for example, polyethylene and fiber composites, and polypropylene and fiber composites such as AZDEL Superlite™ sheets commercially available from AZDEL, Inc.

[0020] Base substrate 54 also includes consolidation areas 66, 68, and 70 pressed into lower surface 58. The thickness of base substrate 54 is smaller in consolidation areas 66, 68, and 70 than in areas adjacent consolidation areas 66, 68, and 70. Tear seam notches 60, 62, and 64 and consolidation areas 66, 68, and 70 are aligned respectively. The periphery of consolidation areas 66, 68, and 70 include a transition portion 72. Transition portion 72 is a radiused and/or sloped portion of consolidation areas 66, 68, and 70 that provides a smooth transition from the low thickness area to a higher thickness area of base substrate 54.

[0021] Base substrate 54 further includes hinge areas 74 and 76 pressed into lower surface 58. Hinge areas 74 and 76 are areas of low consolidation where the thickness of base substrate 54 is higher than areas adjacent hinge areas 74 and 76. Tear seam notches 60, 62, and 64, and hinge areas 74 and 76 define airbag doors 78 and 80. In one embodiment, the thickness of base substrate 54 at hinge areas 74 and 76 is about 5 millimeters to about 9 millimeters. In other embodiments, the thickness of hinge areas 74 and 76 can be higher than 9 millimeters or lower than 5 millimeters. Lower than 5 millimeters thickness requires less pressure in the airbag to move the doors open but also increases the risk of the hinge breaking. Greater than 9 millimeters thickness will usually require higher airbag pressure to move the doors open, but decreases of the hinge breaking. High airbag pressures can be a hazard to vehicle occupants.

[0022] Figure 5 is a cross sectional schematic view of instrument panel 12 through line C-C of Figure 3. Instrument panel 12 includes an intermediate layer 82 on outer surface 56 of base substrate 54 and a cover layer 84 on outer surface 86 of intermediate layer 82. Intermediate layer 82 is formed from a resilient material, for example, a foam material. The resilient material provides protection to vehicle occupants in impact events. Cover layer 84 is formed from any suitable decorative material, for example, a thermoplastic material, leather, fabric, and the like. With the application of intermediate layer 82 and cover layer 84 to base substrate 54, airbag doors 78 and 80 are not visible to a vehicle occupant. In the exemplary embodiment, intermediate layer 82 and cover layer 84 do not contain tear seam scores or notches to

aid the opening of the airbag doors. In other embodiments, at least one of intermediate layer 82 and cover layer 84 also include tear seam notches.

[0023] In operation, during an airbag deployment event, airbag 52 inflates and imparts a force on instrument panel 12. The force causes tear seam notches 60, 62, and 64 to open and causes airbag doors to move to an open position by breaking through intermediate layer 82 and cover layer 84. With airbag doors 78 and 80 in an open position, airbag 52 can fully inflate through instrument panel 12. After airbag 52 deflates, airbag doors 78 and 80 move toward a closed position because of the ductile properties of base substrate 54. Open airbag doors 78 and 80 have smooth surfaces without sharp/hard edges to avoid vehicle occupant injuries.

[0024] Figure 6 is a top schematic view of a portion of instrument panel base substrate 54 in accordance with another embodiment of the present invention. Base substrate 54 includes tear seam notches 88, 90, 92, 94, and 96 pressed into base substrate upper surface 56. Tear seam notches 88, 90, 92, 94, and 96 are arranged in a double-Y pattern. Hinge areas 98, 100, 102, and 104 are pressed in base substrate lower surface 58. Tear seam notches 88, 90, 92, 94, and 96 and hinge areas 98, 100, 102, and 104 define airbag doors 106, 108, 110, and 112. Base substrate 54 also includes consolidation areas 114, 116, 118, 120, and 122 pressed into lower surface 58. The thickness of base substrate 54 is smaller in consolidation areas 114, 116, 118, 120 and 122 than in areas adjacent consolidation areas 114, 116, 118, 120, and 122. Tear seam notches 88, 90, 92, 94, and 96 and consolidation areas 114, 116, 118, 120 and 122 are aligned respectively.

[0025] Figure 7 is a top schematic view of a portion of instrument panel base substrate 54 in accordance with another embodiment of the present invention. Base substrate 54 includes tear seam notches 124, 126 and 128 pressed into base substrate upper surface 56. Tear seam notches 124, 126 and 128 are arranged in a U-shaped pattern. Hinge area 130 is pressed in base substrate lower surface 58. Tear seam notches 124, 126 and 128 and hinge area 130 define airbag door 132. Base substrate 54 also includes consolidation areas 134, 136, and 138 pressed into lower surface 58. The thickness of base substrate 54 is smaller in

consolidation areas 134, 136, and 138 than in areas adjacent consolidation areas 134, 136, and 138. Tear seam notches 124, 126 and 128 and consolidation areas 134, 136, and 138 are aligned respectively.

[0026] Of course, the arrangement of tear seam notches in instrument panel base substrate are not limited to the exemplary embodiments shown in Figures 2, 3, 6, and 7 and described above. Other suitable tear seam notch configurations can be used. Some other suitable, non-limiting, tear seam notch configurations include star, circle, and oval. Also, the tear seam notches can include curves. Further, the above described exemplary embodiments have the tear seam notches pressed into base substrate upper surface 56. In alternative embodiments, the tear seam notches are pressed into base substrate lower surface 58.

[0027] Further, the above described exemplary embodiments are directed to hidden airbag doors in instrument panels. In alternate embodiments, other vehicle components include hidden airbag doors, for example door panels and trim panels.

[0028] While the invention has been described in terms of various specific embodiments, those skilled in the art will recognize that the invention can be practiced with modification within the spirit and scope of the claims.

THE CLAIMS DEFINING THE INVENTION ARE AS FOLLOWS:

1. An instrument panel including:
 - a thermoplastic base substrate having a first surface and a second surface;
 - 5 at least one tear seam notch pressed into said first surface of said base substrate;
 - at least one consolidated area pressed into said second surface of said base substrate, said at least one consolidated area aligned with said at least one tear seam notch;
 - 10 at least one hinge area including an area of low consolidation wherein a thickness of said base substrate at said low consolidation area is greater than a thickness of said base substrate at said at least one consolidated area, said at least one tear seam notch and said at least one hinge area defining at least one airbag door, wherein a width of said at least one consolidated area is equal to or greater than at least
 - 15 one tear seam notch.

2. An instrument panel in accordance with Claim 1 wherein each said consolidated area includes a transition portion located around the periphery of each said consolidated area.
- 20 3. An instrument panel in accordance with Claim 2 wherein said transition portion includes a radius of curvature.

4. An instrument panel in accordance with any one of Claims 1 to 3 wherein said
- 25 base substrate is compression molded into a predetermined shape of said instrument panel.

5. An instrument panel in accordance with any one of Claims 1 to 4 further including an intermediate layer adjacent said first surface of said base substrate, said
- 30 intermediate layer comprising a resilient material.

6. An instrument panel in accordance with Claim 5 wherein said resilient material comprises a foam material.

7. An instrument panel in accordance with Claim 5 or 6 further including an outer layer adjacent said intermediate layer.
8. An instrument panel in accordance with any one of Claims 1 to 7 wherein a thickness of said base substrate at said hinge low consolidation area is greater than a thickness of said base substrate at an area adjacent said hinge area.
9. An instrument panel system including an instrument panel and an airbag, said air bag positioned adjacent said instrument panel, said instrument panel including:
- 10 a thermoplastic base substrate having a first surface and a second surface, said air bag positioned adjacent said second surface of said base substrate;
- at least one tear seam notch pressed into said first surface of said base substrate;
- at least one consolidated area pressed into said second surface of said base substrate, said at least one consolidated area aligned with said at least one tear seam notch;
- at least one hinge area including an area of low consolidation wherein a thickness of said base substrate at said low consolidation area is greater than a thickness of said base substrate at said at least one consolidated area, said at least one tear seam notch and said at least one hinge area defining at least one airbag door, said tear seam notch configured to open when said airbag deploys permitting said airbag to deploy through said instrument panel, wherein a width of said at least one consolidated area is equal to or greater than at least one tear seam notch.
10. An instrument panel system in accordance with Claim 9 wherein each said consolidated area includes a transition portion located around the periphery of each said consolidated area.
11. An instrument panel system in accordance with Claim 10 wherein said transition portion includes a radius of curvature.
12. An instrument panel system in accordance with Claim 9 wherein said base substrate is compression molded into a predetermined shape of said instrument panel.

13. An instrument panel system in accordance with Claim 9 wherein said instrument panel further includes an intermediate layer adjacent said first surface of said base substrate, said intermediate layer comprising a resilient material.
- 5 14. An instrument panel in accordance with Claim 13 wherein said instrument panel further includes an outer layer adjacent said intermediate layer, said at least one tear seam notch is not visible through said outer layer before deployment of said airbag.
- 10 15. An instrument panel including:
a thermoplastic base substrate having a first surface and a second surface;
an intermediate layer adjacent said first surface of said base substrate, said intermediate layer including a resilient material;
an outer layer adjacent said intermediate layer;
15 at least one airbag door defined by at least one tear seam notch pressed into said base substrate and at least one hinge area including an area of low consolidation in said base substrate, said at least one airbag door not visible through said outer layer before an airbag deployment causes said at least one airbag door to open; and
at least one consolidated area pressed into said second surface of said base
20 substrate, said at least one consolidated area aligned with said at least one tear seam notch.
16. An instrument panel in accordance with Claim 15 wherein said at least one tear seam notch is pressed into said first surface of said base substrate.
- 25 17. An instrument panel in accordance with Claim 15 or 16 wherein a thickness of said base substrate at said hinge low consolidation area is greater than a thickness of said base substrate at said at least one consolidated area.
- 30 18. An instrument panel in accordance with Claim 15 or 16 wherein a thickness of said base substrate at said hinge low consolidation area is greater than a thickness of said base substrate at an area adjacent said hinge area.

19. A method of producing an instrument panel system including an instrument panel and an airbag, said method including press molding a thermoplastic base substrate having a first surface and a second surface into a predetermined shape of the instrument panel, wherein press molding the base substrate includes:

- 5 pressing at least one tear seam notch into the base substrate;
- pressing at least one consolidated area into the second surface of the base substrate, the at least one consolidated area aligned with the at least one tear seam notch;
- pressing at least one hinge area into the second surface of the base substrate,
- 10 each hinge area including an area of low consolidation wherein a thickness of the base substrate at the low consolidation area is greater than the thickness of the base substrate at the at least one consolidated area the at least one tear seam notch and the at least one hinge area defining at least one airbag door, wherein a width of said at least one consolidated area is equal to or greater than at least one tear seam notch.

15

20. A method in accordance with Claim 19 wherein each consolidation area includes a transition portion located around the periphery of the consolidation area.

21. A method in accordance with Claim 19 or 20 wherein a thickness of the base substrate at the hinge low consolidation area is greater than a thickness of the base substrate at the at least one consolidated area.

22. A method in accordance with any one of Claims 19 to 21 further including forming an intermediate layer adjacent the first surface of the base substrate, the
25 intermediate layer comprising a resilient material.

23. A method in accordance with Claim 22 further including forming an outer layer adjacent the intermediate layer.

30 24. A method in accordance with Claim 22 or 23 further including positioning the airbag adjacent the at least one airbag door.

25. A method in accordance with any one of Claims 19 to 24 wherein pressing at least one tear seam notch into the base substrate includes pressing at least one tear seam notch into the first surface of the base substrate.
- 5 26. A method in accordance with any one of Claims 19 to 24 wherein pressing at least one tear seam notch into the base substrate includes pressing at least one tear seam notch into the second surface of the base substrate.
- 10 27. An instrument panel substantially as hereinbefore described with reference to any one of the embodiments shown in the drawings.

1/4

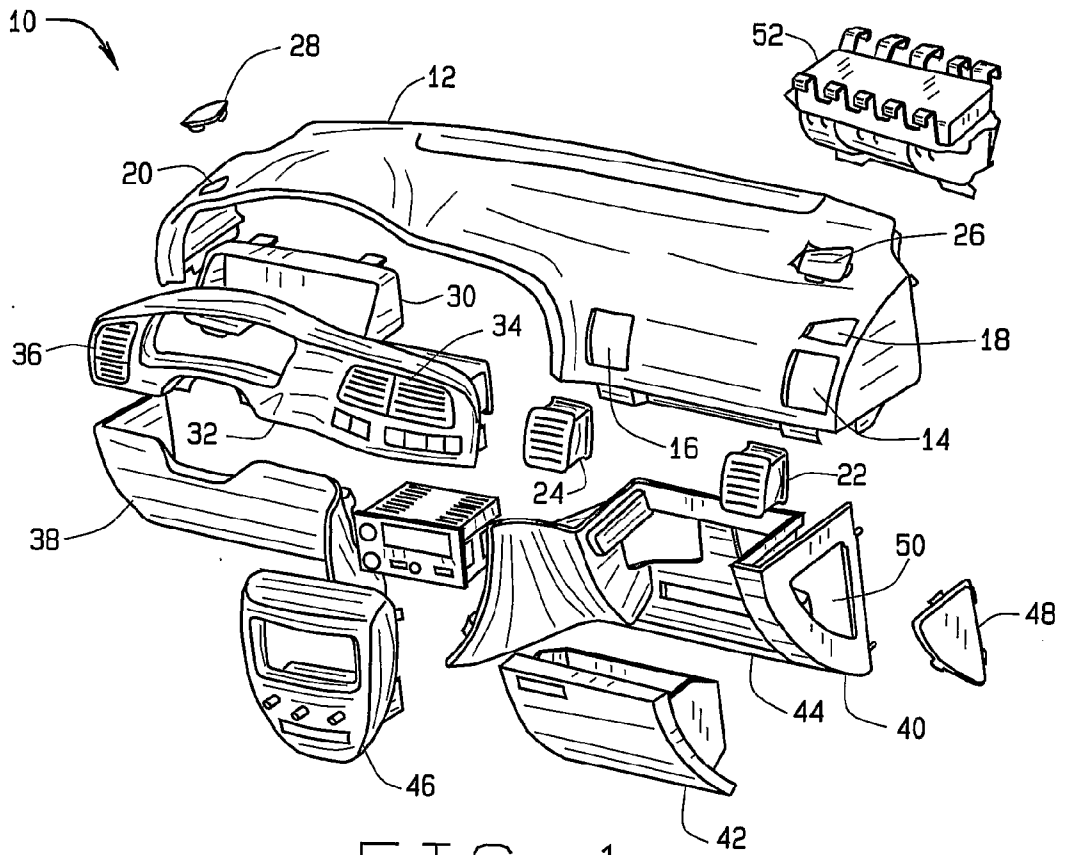

FIG. 1

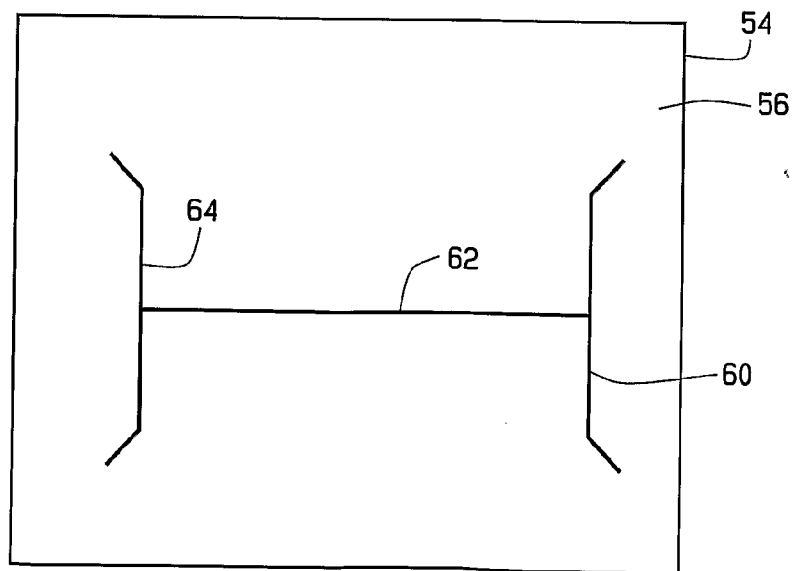

FIG. 2

2/4

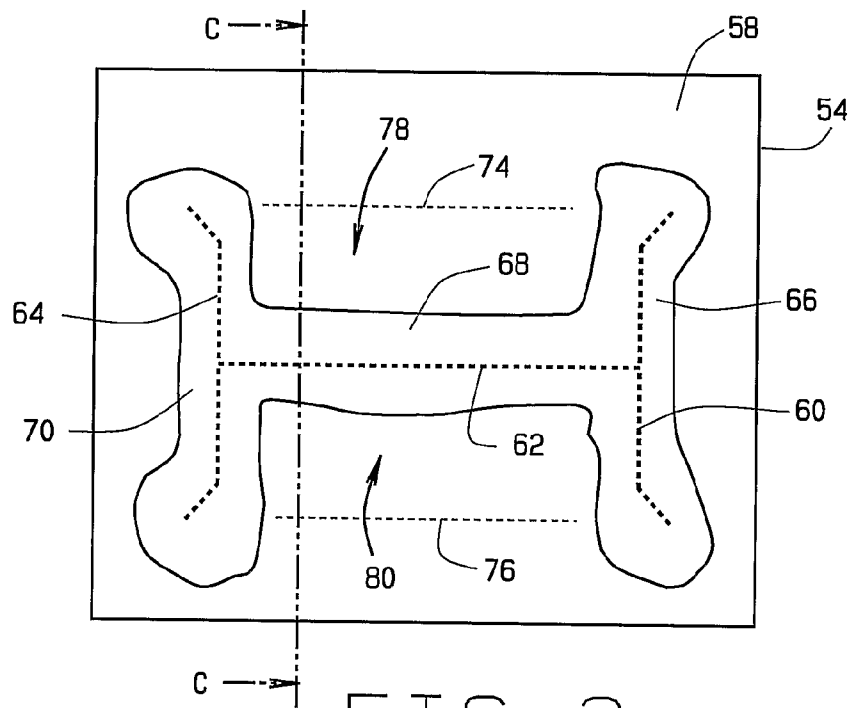

FIG. 3

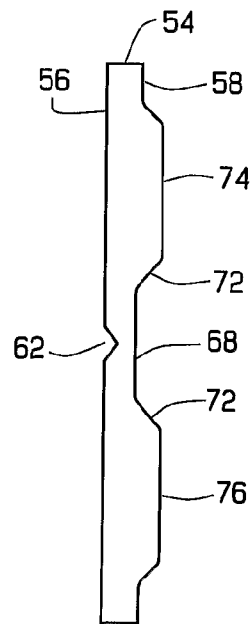

FIG. 4

3/4

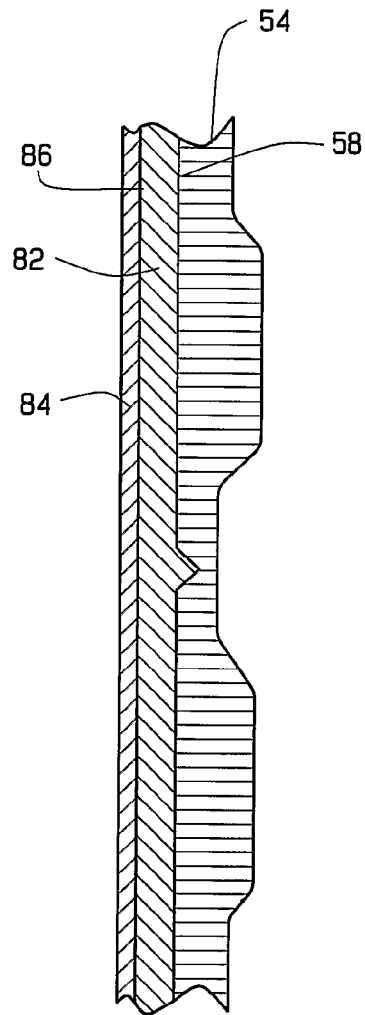

FIG. 5

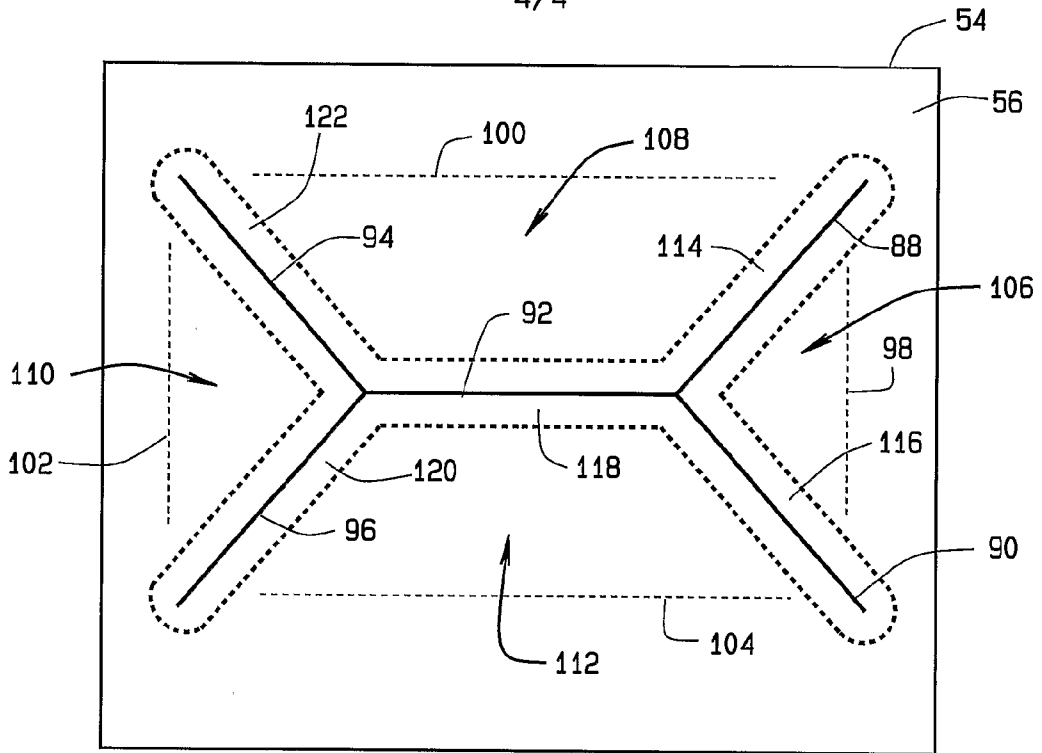

FIG. 6

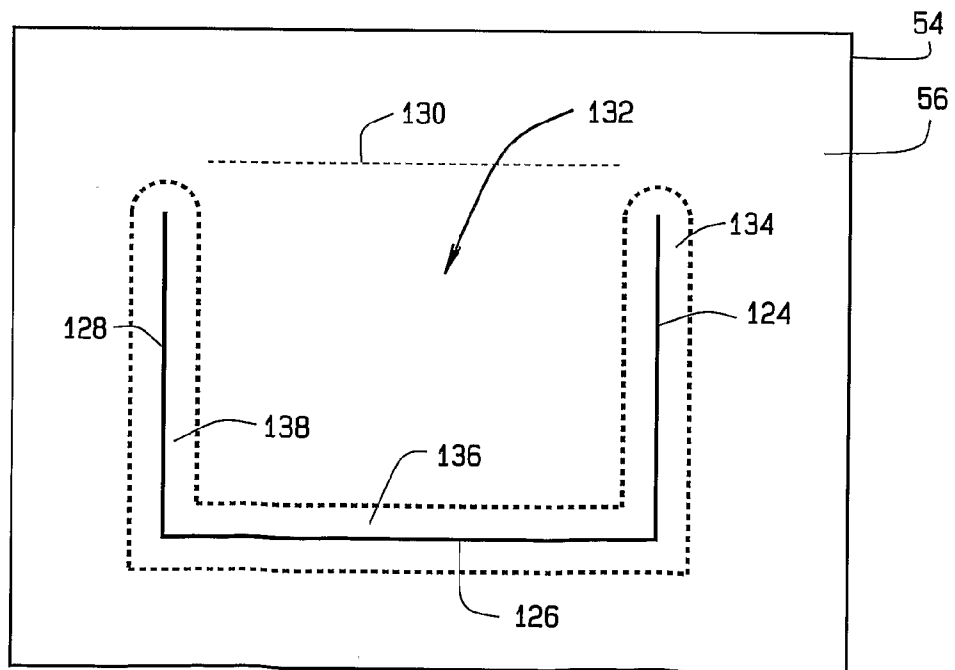

FIG. 7