

- (21) Application No 8104076
- (22) Date of filing  
10 Feb 1981
- (30) Priority data
- (31) 55/015680  
55/015681
- (32) 12 Feb 1980
- (33) Japan (JP)
- (43) Application published  
30 Sep 1981
- (51) INT CL<sup>3</sup> H04R 17/10
- (52) Domestic classification  
H4J 30X 31J 31T 31V C  
H1E 1
- (56) Documents cited  
GB 1504203  
GB 1475355  
GB 1260387
- (58) Field of search  
H4J
- (71) Applicant  
Kureha Kagaku Logyo  
Kabushiki Kaisha  
9-11 Horidome-cho  
1-chome  
Nihonbashi  
Chuo-ku  
Tokyo  
Japan
- (72) Inventors  
Hiroshi Obara  
Kenichi Nakamura  
Aisaku Nagai
- (74) Agents  
Reddie & Grose  
16 Theobalds Road  
London WC1X 8PL

(54) **Piezoelectric type electroacoustic transducer**

(57) An electroacoustic transducer of the piezoelectric type, suitable particularly for use in the ultrasonic wave range, utilizes the piezoelectric characteristics in the perpendicular direction of a piezoelectric polymer film. The electroacoustic transducer contains a piezoelectric polymer film 12 provided at each side with an electrode 14, one of the electrodes 14a being backed or lined with a porous material layer 16 as of a foam or fibrous material, thereby utilizing the surface of the other electrode 14b as an acoustic transmission surface and as an acoustic reception surface. The transducer may be subjected to electroacoustic conversion in a frequency band ranging from approximately 0.6 to approximately 1.4

times the perpendicular fundamental resonance frequency of the piezoelectric polymer film.

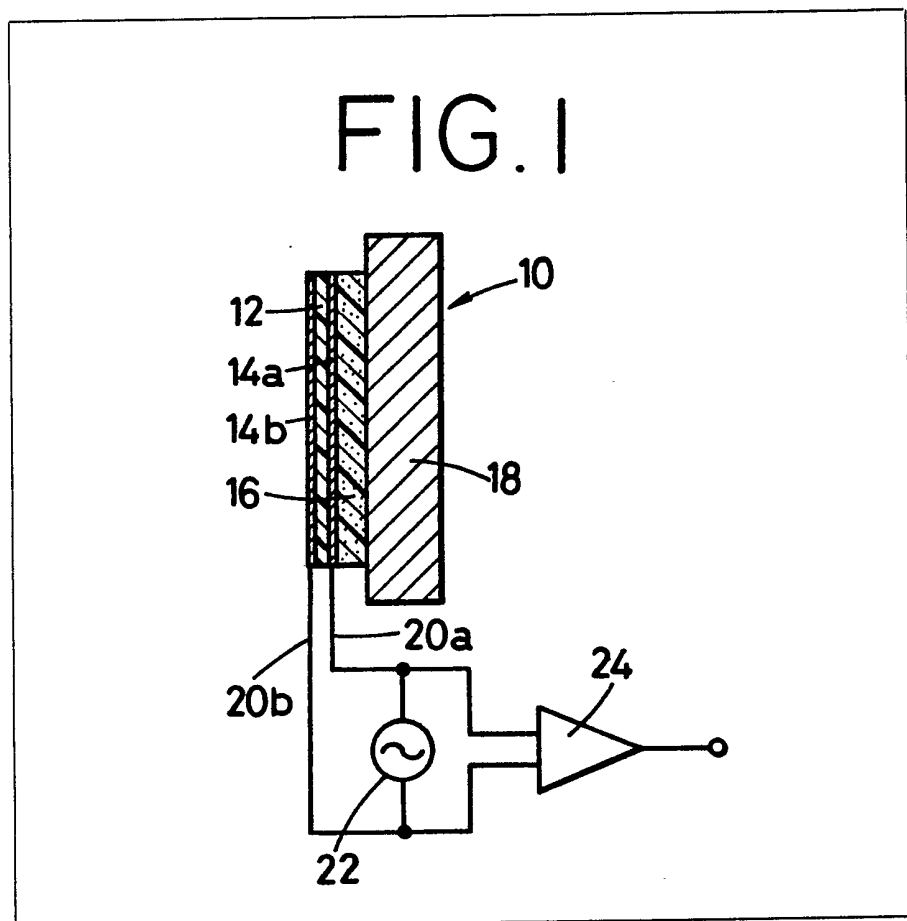

FIG. 1

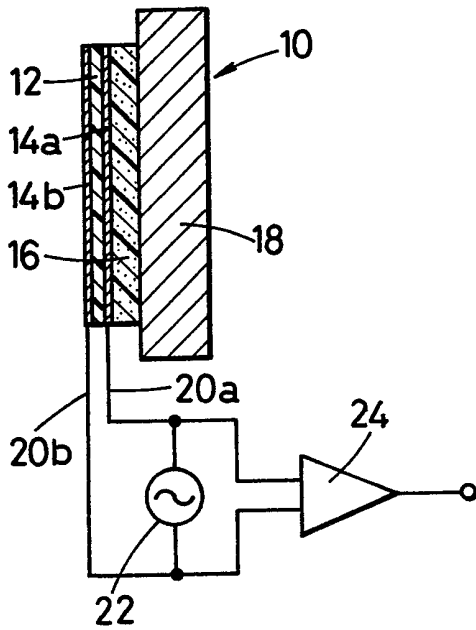

FIG. 2

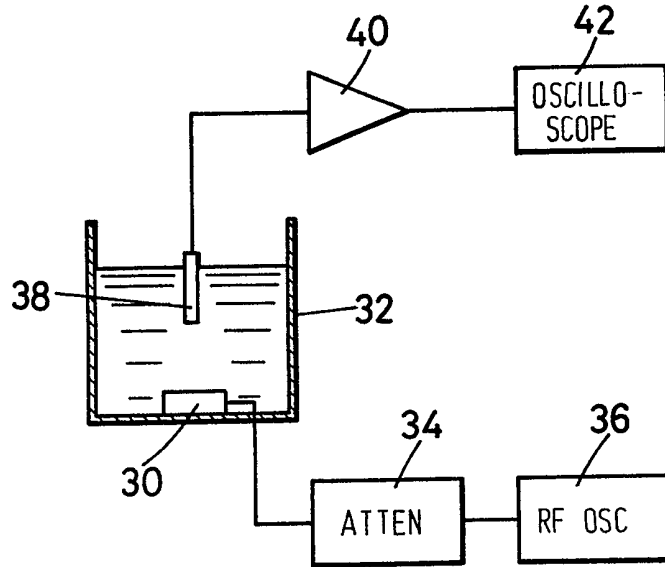

FIG. 3

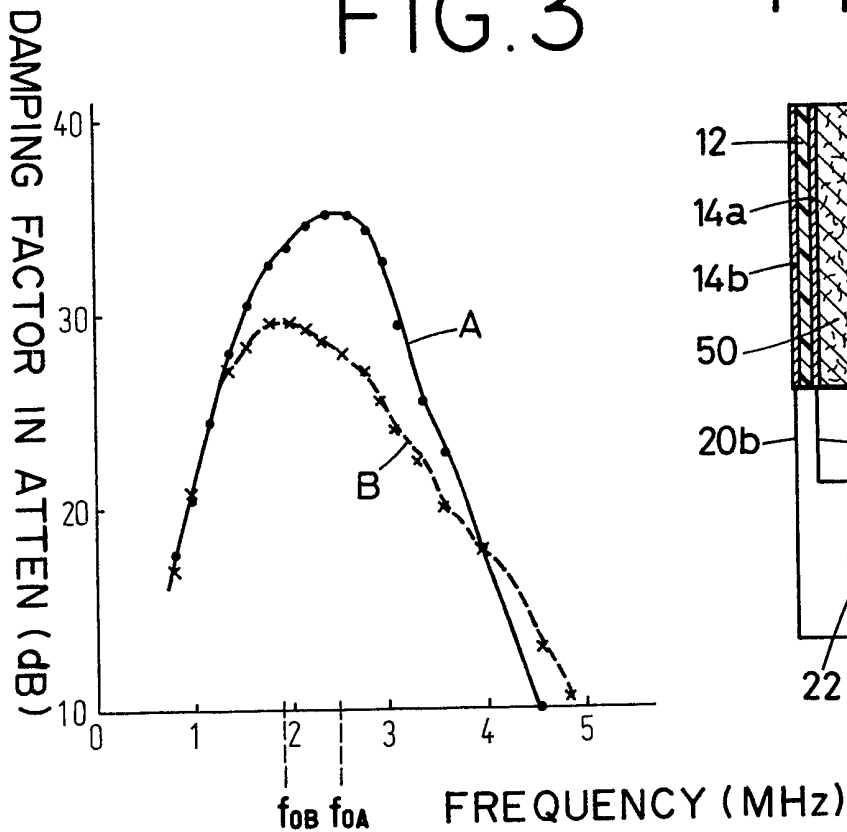
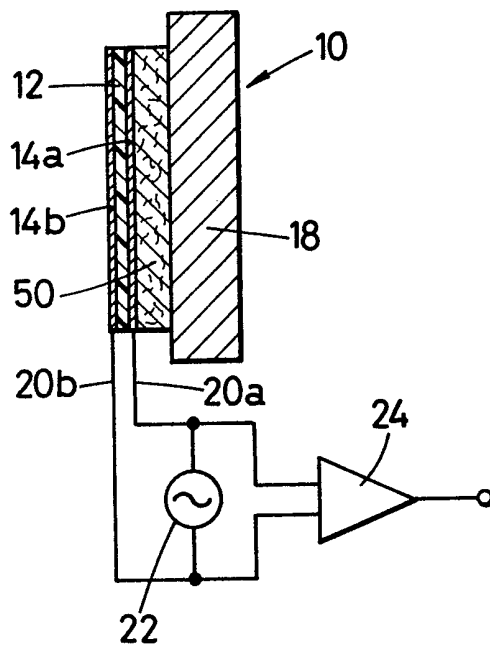

FIG. 4



## SPECIFICATION

**Piezoelectric type electroacoustic transducer**

## 1. Field of the Invention

The present invention relates to a piezoelectric type electroacoustic transducer utilizing the piezoelectric characteristics in the perpendicular direction of a piezoelectric polymer film, which is suitable for use in the ultrasonic wave range.

## 2. Brief Description of the Prior Art

Electroacoustic transducers which employ piezoelectric polymer films such as polyvinylidene, polyvinyl fluoride or the like may be classified largely into two groups in accordance with a variation in piezoelectric characteristics of the polymer films utilized. The first group is one which utilizes the piezoelectric characteristics caused by contraction and expansion of polymer films as illustrated in Japanese Patent Publication No. 26,890/1974 and the second is one which utilizes the perpendicular piezoelectric characteristics of polymer films as illustrated in Japanese Patent Publication No. 23,439/1976. The first group is desirably used for electroacoustic transducers for use in the audiofrequency range and the second for electroacoustic transducers for use in the ultrasonic wave range. Of the electroacoustic transducers, those of the piezoelectric type have recently drawn wide attention rapidly, for example, as medical probes with the development of ultrasonic medical science.

The electroacoustic transducers of the piezoelectric type employ oscillation frequencies ranging usually within the scope centering around the fundamental resonance frequency  $f_0 = v/2t$  (where:  $v$  = velocity of sound;  $t$  = thickness of piezoelectric element) in the perpendicular of the piezoelectric element from the standpoint of efficiency in electroacoustic conversion. As the piezoelectric elements, there have been employed piezoelectric polymer elements and piezoelectric ceramic elements. The piezoelectric polymer elements are superior to the piezoelectric ceramic elements in characteristics that the piezoelectric polymer elements possess a wide-band performance because they are small in quality factor (Q-factor), that they are matched well with the living body with respect to the acoustic impedance, and that they are flexible and unlikely to be damaged. The piezoelectric polymer elements, however, have the defect that the electroacoustic conversion efficiency is lower than the piezoelectric ceramic elements even if the piezoelectric polymer elements are employed within the scope near by the perpendicular fundamental resonance frequency. Accordingly, attempts to commercialize electroacoustic transducers of the piezoelectric

type utilizing the piezoelectric polymer elements have not been completed yet.

Japanese Patent Publication No. 23,439/1976 discloses the piezoelectric type electroacoustic transducer utilizing the perpendicular piezoelectric characteristics of a piezoelectric film in which the piezoelectric film is backed or lined at one side thereof with a hard material having an elastic modulus and a mass larger than those of the polymer film. The frequency band of the piezoelectric polymer film employed therefor is far below the fundamental resonance frequency in the perpendicular direction of the polymer film.

**SUMMARY OF THE INVENTION**

Therefore, a primary object of the present invention is to provide an electroacoustic transducer utilizing the perpendicular piezoelectric characteristics of piezoelectric polymer films which possesses an improved efficiency in the electroacoustic conversion and which is particularly adaptable for use in the ultrasonic wave range.

Another object of the present invention is to provide an electroacoustic transducer containing a piezoelectric polymer film with its one surface backed or lined with a porous material and the other surfaces functioning as an acoustic transmission surface or an acoustic reception surface, thereby improving the electroacoustic conversion efficiency particularly within the scope nearby the perpendicular fundamental resonance frequency of the piezoelectric polymer film employed.

Various other objects, advantages and features of the present invention will become readily apparent from the detailed description which follows, and the novel features will be particularly pointed out in the appended claims.

**BRIEF DESCRIPTION OF THE DRAWINGS**

*Figure 1* is a schematic illustration illustrating one embodiment of the piezoelectric type electroacoustic transducer in accordance with the present invention, in which the transducer body is illustrated as a cross-sectional view.

*Figure 2* is a schematic illustration illustrating a method of measurement of the electroacoustic conversion efficiency of the piezoelectric type electroacoustic transducer of Fig. 1, in which a water bath is illustrated as a cross-sectional view.

*Figure 3* is a graph illustrating the measurement results obtained by the method of Fig. 2.

*Figure 4* is a schematic illustration illustrating another embodiment of the piezoelectric type electroacoustic transducer in accordance with the present invention, in which the transducer body is illustrated as a cross-sectional view.

**DETAILED DESCRIPTION OF THE PREFERRED EMBODIMENTS**

Referring to Figs. 1 and 4, the electroacoustic transducers in accordance with the present invention contain each a transducer body 10 which is comprised at least of a piezoelectric polymer film 12 and a porous material layer 16 or 50.

The piezoelectric polymer material which may be employed for the piezoelectric polymer film 12 may be any piezoelectric polymer film which are applicable to the electroacoustic transducers and may include, for example, a fluorine-containing polymer such as a polyvinyl fluoride homopolymer or copolymer or a polyvinylidene fluoride homopolymer or copolymer. The piezoelectric polymer film 12 may have a thickness ranging generally from about 10 to 1,000 microns although it is not limited to a particular one.

The polymer film 12 is provided at the both surfaces thereof with thin film electrodes 14a and 14b. The thin film electrodes 14a and 14b may be of a conductive material such as a metal, e.g., aluminum or nickel.

The piezoelectric polymer film 12 having the electrode 14a at its surface is further provided with a porous material layer. The porous material to be employed for the porous material layer as illustrated in Fig. 1 may be a foam 16 such as, for example, a polyurethane foam, a polystyrene foam, a foam rubber or any other appropriate foamed polymer. The porous material to be used in the embodiment as illustrated in Fig. 4 may be a fibrous material 50 such as, for example, a paper having a porous structure, a non-woven fabric, a woven fabric or a knitted fabric. Of the fibrous materials 50, the non-woven fabric, woven fabric and knitted fabric may be of cloth fiber or of glass fiber. The porous materials may be ones having a closed-cell or open-cell structure or a structure having a combination of closed and open cells or an interstitial structure and they may be employed as composite layers. The porous materials which may be preferably employed for the present invention may be ones particularly having a small apparent specific gravity with respect to the true specific gravity, that is to say, having a large porosity. A practical value of the porosity for the porous material may range generally from about 30% to about 99.5%. The polyurethane foam to be employed for the structure as shown in Fig. 1 has an apparent specific gravity of about 0.02, while it has a true specific gravity of about 1.18. Thus, it has a porosity of about 98%. The fibrous material to be employed for the structure as shown in Fig. 4 may have a porosity of about 50%.

The porous material layers 16 and 50 may have been supported on an appropriate base plate 18. The base plate 18 may be suitably of a relatively thick hard material such as, for example, a metal or plastic material. The base plate 18 can function merely as a support and

it is preferably constructed so as to exert no or less influence on the polymer film 12 through any acoustic reflection.

The other film electrode 14b which is not provided at its exterior surface with any material can function as an acoustic transmission surface or as an acoustic reception surface. The thin film electrodes 14a and 14b are connected electrically through leads 20a and 20b, respectively, to a high-frequency generator 22. The high-frequency generator 22 is arranged so as to generate output frequencies within the scope as high as from approximately 0.6 to approximately 1.4 times the perpendicular fundamental resonance frequency of the piezoelectric polymer film 12 used. When the leads 20a and 20b are further connected electrically to an amplifier 24, it is advantageous and convenient because the transducer can be applied for both transmission and reception in accordance with a pulse echo system.

Specific features of the electroacoustic transducer in accordance with the present invention will be described more in detail with reference to Figs. 1 and 4.

Referring first to Fig. 1, a piezoelectric polyvinylidene fluoride film 12 having a thickness of 350 microns is provided at its both surfaces with nickel electrodes 14a and 14b and cut into rectangular pieces having an appropriate size, for example, 25 mm × 40 mm. A double-side adhesive polyurethane foam 16 having a thickness of, for example, 3 mm is adhered at its one surface to the nickel electrode 14a and at the other surface to a Bakelite base plate 18 having an appropriate thickness, for example, 20 mm and an appropriate size, for example, 30 mm × 50 mm so as to locate at the middle portion of the base plate 18.

As a comparative example, there is provided a transducer having a structure having substantially the same size as immediately mentioned such that a piezoelectric polyvinylidene fluoride film 12 having nickel electrodes 14a and 14b at its both sides is attached directly to a Bakelite base plate 18 by means of an epoxy type adhesive.

Turning now to Fig. 4, the transducer in accordance with the present invention is substantially the same as that shown in Fig. 1 with the exception that a glass cloth layer 50 is employed in place of the foam layer 16. The glass cloth layer 50 may be as thick as about 5 mm and thicker than the foam layer 16.

The electroacoustic transducer in accordance with the present invention is determined for its efficiency in electroacoustic conversion by employing the transducer prepared hereinabove as having the structure as shown in Fig. 1 in comparison with the transducer prepared for a comparative example.

The efficiency is measured in water in ac-

cordance with a method of measurement as shown in Fig. 2. A specimen 30 having either of the transducer body 10 as shown in Figs. 1 and 4, respectively, is placed in water at the bottom of a water bath 32. The electrodes are connected through an attenuator 34 to the output side of a radio-frequency oscillator 36 (Pulse Modulator and Receiver Model 6600 of Matec, Inc.). A hydrophone 38 is placed above the specimen 30 in water at the upper portion of the water bath 32 so as to arrange its reception surface apart in 30 cm from the specimen 30. The hydrophone 38 is connected at its output side through an amplifier 40 to an oscilloscope 42.

Turning now to Fig. 3, values of the damping factor of the attenuator 34 are plotted against the frequencies of the radio-frequency oscillator 36. The attenuator 34 is adjusted to as to make the output of the hydrophone 38 become constant while keeping the output of the oscillator 36 constant at 1,000 V<sub>p-p</sub> (where the symbol "p-p" means to refer to a peak-to-peak value). It is thus to be understood that the electroacoustic conversion efficiency of the specimen 30 is considered high when the damping factor in the attenuator 34 is high because the voltage of the oscillator 36 applied to the specimen 30 is low.

Fig 3 illustrates the results of the measurement carried out by the method illustrated in Fig. 2. The curved line A indicates the results when the transducer body 10 as shown in Fig. 1 was employed and the dotted lines B indicate the results when the comparative example obtained hereinabove was used as the specimen 30. It is apparent from Fig. 3 that there is no big difference or deviation between the both specimens in the damping factor in areas far from the perpendicular fundamental resonance frequency  $f_o$ . It is to be noted herein that, as the perpendicular fundamental resonance  $f_o$  deviates to some extent between the two specimens, that of the specimen 30 of the transducer body tested as an example in accordance with the present invention is indicated as  $f_{oA}$  and that of the comparative example is indicated as  $f_{oB}$ . It is to be noted, however, that there is a substantially large difference in the damping factor around the perpendicular fundamental resonance frequency  $f_o$ , particularly within the scope ranging from approximately 0.6 to approximately 1.4 times the perpendicular fundamental resonance frequency. It is accordingly to be understood from Fig. 3 that the transducer body 10 as shown in Fig. 1 in accordance with the present invention is better in the electroacoustic conversion efficiency than the comparative example and the efficiency is increased in the order of approximately 6 dB at the resonance point.

In Fig. 3, the perpendicular fundamental resonance frequency  $f_{oA}$  of the transducer body 10 as illustrated in Fig. 1 is set at

approximately 2.5 MHz. The perpendicular fundamental resonance frequency  $f_{oA}$  may be arranged to range within an appropriate scope from 1 to 15 MHz when the transducer body 10 is applied to a medical probe, from about 15 to 200 MHz for application to a microscope, and from about several tens KHz to 1 MHz for application to a sonar.

When the transducer body 10 as shown in Fig. 4 is tested, it is found that it can provide substantially the same results as shown in the curved lines A in Fig. 3.

The electroacoustic transducer in accordance with the present invention provides an improved electroacoustic conversion efficiency on account of the effect of reflection by means of the porous material such as a foam or a fibrous material which is provided at the one side of the piezoelectric polymer film. The improved efficiency is securedly produced where the frequencies to be applied are within a scope ranging from approximately 0.6 to approximately 1.4 times the perpendicular fundamental resonance frequency of the piezoelectric polymer film. Accordingly, the electroacoustic transducer of the piezoelectric type in accordance with the present invention is particularly adaptable for transmission and/or reception of especially ultrasonic waves.

Although several particular embodiments of the present invention have been described in detail hereinabove with reference to the accompanying drawings, it is to be understood that the invention is not limited to those precise embodiments, and that various changes and modifications may be effected therein by persons skilled in the art without departing from the scope or spirit of the invention as defined in the appended claims.

## CLAIMS

1. An electroacoustic transducer comprising:
  - a piezoelectric polymer film having an electrode on each of the sides thereof; and
  - a porous material layer provided on one of the sides of the piezoelectric polymer film; thereby arranging the exterior surface of the electrode on which the piezoelectric polymer film is not provided so as to function as an acoustic transmission surface and/or an acoustic reception surface; and
  - thereby effecting the electroacoustic conversion in the frequency band within a scope ranging from approximately 0.6 to approximately 1.4 times the perpendicular fundamental resonance frequency of the piezoelectric polymer film.
2. The electroacoustic transducer according to Claim 1, wherein the porous material has a porosity of approximately 30 to approximately 99.5%.
3. The electroacoustic transducer according to Claim 1 or 2, wherein the porous material is a foam.

4. The electroacoustic transducer according to Claim 3, wherein the foam is a member selected from the group consisting of a polyurethane foam, a polystyrene foam, a foam rubber and other foamed polymer.
5. The electroacoustic transducer according to Claim 1 or 2, wherein the porous material is a fibrous material.
6. The electroacoustic transducer according to Claim 5, wherein the fibrous material is a member selected from the group consisting of a paper, a non-woven fabric, a woven fabric and a knitted fabric.
7. The electroacoustic transducer according to Claim 6, wherein the non-woven fabric, the woven fabric or the knitted fabric is of cloth fiber or of glass fiber.
8. The electroacoustic transducer according to Claim 1, 2, 3 or 5, wherein the layer of the porous material is interposed between a hard base plate support and the electrode provided on the piezoelectric polymer film.
9. The electroacoustic transducer according to Claim 8, wherein the hard base plate support is a metal or a plastic material.
10. The electroacoustic transducer according to Claim 1 or 8, wherein the electrode is a thin film electrode of nickel or aluminum.
11. The electroacoustic transducer according to Claim 1 or 8, wherein the piezoelectric polymer film is of a fluorine containing polymer.
12. The electroacoustic transducer according to Claim 11, wherein the fluorine-containing polymer is a polyvinyl fluoride homopolymer or copolymer of a polyvinylidene fluoride homopolymer or copolymer.
13. The electroacoustic transducer according to Claim 1, 8 or 10, wherein the electrode is connected to a high-frequency generating means arranged so as to generate the output of the frequency within a scope ranging from approximately 0.6 to approximately 1.4 times the perpendicular fundamental resonance frequency of the piezoelectric polymer film.
14. The electroacoustic transducer according to Claim 13, wherein the electrode is further connected to an amplifier.