

(No Model.)

H. L. JONES.  
IRON FENCE.

No. 313,825.

Patented Mar. 10, 1885.

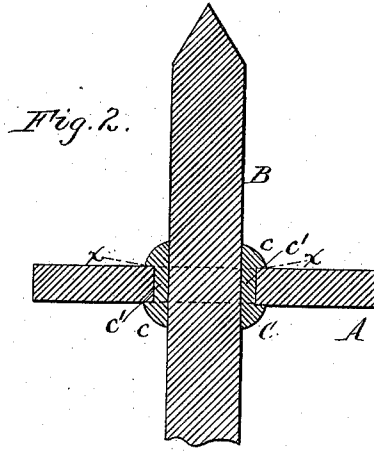
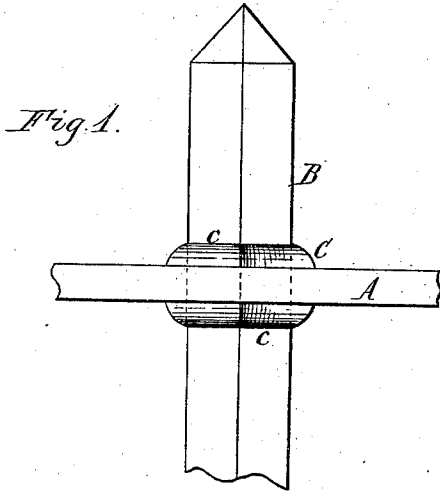

*Fig. 3.*

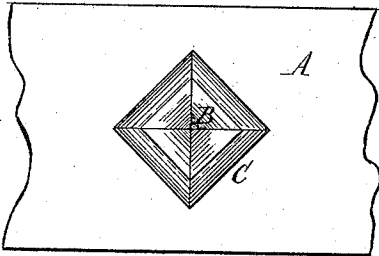

*Fig. 4.*

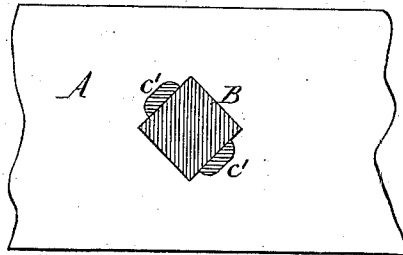

*Fig. 5.*

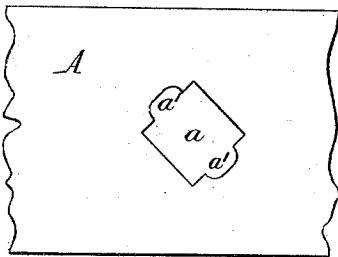

*Fig. 6.*

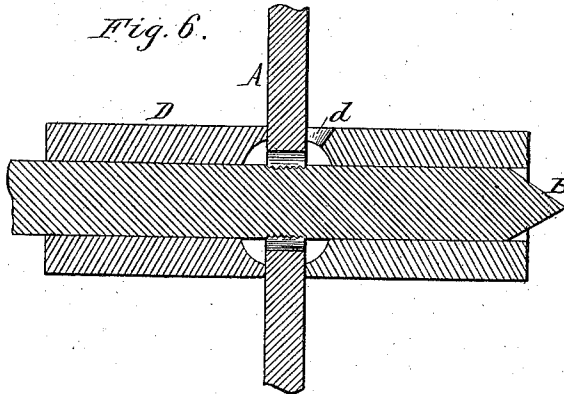

Witnesses:

Geo. E. Pitman  
Theo. L. Popp

H. L. Jones Inventor.  
By Wilhelm Honner  
Attorneys.

# UNITED STATES PATENT OFFICE.

HENRY L. JONES, OF BUFFALO, NEW YORK.

## IRON FENCE.

SPECIFICATION forming part of Letters Patent No. 313,825, dated March 10, 1885.

Application filed April 11, 1884. (No model.)

To all whom it may concern:

Be it known that I, HENRY L. JONES, of Buffalo, in the county of Erie and State of New York, have invented a new and useful Improvement in Iron Fences, of which the following is a specification.

This invention relates to a certain new and useful improvement in that class of iron fences which are composed of vertical pickets and longitudinal rails or stringers; and it has for its object to provide a cheap and effective means of securing the pickets in the openings of the rails or stringers.

With this object in view my invention consists of the improvements which will be hereinafter more fully described, and pointed out in the claim.

In the accompanying drawings, Figure 1 is a side elevation of a portion of a fence picket and rail with my improved means of connection applied thereto. Fig. 2 is a sectional elevation thereof; Fig. 3, a top plan view. Fig. 4 is a cross-section in line *xx*, Fig. 2. Fig. 5 is a top plan view of a portion of one of the rails or stringers, and Fig. 6 is a fragmentary sectional elevation of a rail and picket with a mold applied thereto.

Like letters of reference denote like parts in the several figures.

A represents a longitudinal rail or stringer formed of a flat bar of iron, and B the picket which passes through the opening *a* in the rail A. The pickets B are preferably made square or rectangular in cross-section, and the openings *a* in the stringer of corresponding form and of the required size to enable the pickets to fit snugly therein. The openings *a* are provided with enlargements or recesses *a'* on opposite sides of the pickets.

C represents my improved fastening, whereby the pickets are firmly secured to the stringers. The fastening C consists of two cast-metal flanges, *c c*, preferably of Babbitt or other suitable metal, which surround the pickets, one above and the other below the string-

ers A. The flanges *cc* are connected together by ribs or bars *c'*, which extend through the recesses *a'* in the stringer. The fastening C is cast around the pickets by means of a mold, D, as shown in Fig. 6. The mold D is preferably made in four sections, to enable it to be placed in position on the pickets, and is provided with a channel or groove, *d*, through which the molten metal is poured. The picket B being placed in the opening *a* of the rail A, the mold D is placed upon the picket B close against the rail A, one half of the mold being above and the other half of the mold below the rail. The molten metal is then poured into the mold through the opening *d*, and passes through the recesses *a' a'* of the opening *a* and around the edges of the picket B, above and below the rail A, forming the connected rings *c c*, whereby the picket is rigidly secured in place in a very simple and inexpensive manner.

The pickets may be provided with grooves or depressions, which will be filled by the metal of the fastening C, and whereby the latter will be firmly connected with the pickets.

I claim as my invention—

In a metallic fence, the combination, with the picket B and the stringer A, provided with an opening, *a*, to receive the picket, said opening having recesses *a' a'* on opposite sides of the picket, of a fastening device composed of the flanges *c c*, arranged above and below the stringer, and connecting-ribs, *c'*, seated in the recesses *a'* of the stringer and held thereon against turning, said flanges *c c* and connecting-ribs *c'* being made in one piece and secured to the stringer and picket by being cast thereon, substantially as set forth.

Witness my hand this 5th day of April, 1884.

HENRY L. JONES.

Witnesses:

FRANK S. JONES,  
JNO. J. BONNER.