



US00D752458S

(12) **United States Design Patent**
Blanc-Tailleur

(10) **Patent No.:** **US D752,458 S**

(45) **Date of Patent:** **** Mar. 29, 2016**

(54) **APPARATUS FOR AUTOMATED TEST OF AVIONICS EQUIPMENT**

(71) Applicant: **CASSIDIAN TEST & SERVICES,**
Elancourt (FR)

(72) Inventor: **Philippe Blanc-Tailleur,** Labege
Innopole (FR)

(73) Assignee: **CASSIDIAN TEST & SERVICES,**
Elancourt (FR)

(**) Term: **14 Years**

(21) Appl. No.: **29/499,578**

(22) Filed: **Aug. 15, 2014**

(30) **Foreign Application Priority Data**

Feb. 18, 2014 (EM) 002407205-0001

(51) **LOC (10) Cl.** **10-04**

(52) **U.S. Cl.**
USPC **D10/75; D14/300**

(58) **Field of Classification Search**

USPC D10/46, 75; D14/300-305
CPC G01R 31/008; G01R 31/2834; G01R
31/2832; G06F 11/273; G06F 11/2733;
G06F 11/2736; G06F 11/277; H04L 12/2697;
H04L 2012/4028

See application file for complete search history.

(56) **References Cited**

U.S. PATENT DOCUMENTS

5,469,542 A * 11/1995 Foster G06F 11/2242
709/224
8,270,308 B2 * 9/2012 Su H04L 12/2697
370/244

* cited by examiner

Primary Examiner — Antoine D Davis

(74) *Attorney, Agent, or Firm* — Pillbury Winthrop Shaw
Pittman LLP

(57) **CLAIM**

The ornamental design for a apparatus for automated test of avionics equipment, as shown and described.

DESCRIPTION

FIG. 1 is an isometric view according to my design;
FIG. 2 is a front view of the design of FIG. 1;
FIG. 3 is a left view of the design of FIG. 1;
FIG. 4 is a right view of the design of FIG. 1;
FIG. 5 is a top view of the design of FIG. 1; and
FIG. 6 is an additional isometric view according to my design;
In accordance with a second embodiment of the present invention:

FIG. 7 is an isometric view according to my design;
FIG. 8 is a front view of the design of FIG. 7;
FIG. 9 is a left view of the design of FIG. 7;
FIG. 10 is a right view of the design of FIG. 7;
FIG. 11 is a top view of the design of FIG. 7; and,
FIG. 12 is an additional isometric view according to my design.

The rear and bottom of the apparatus for automated test of avionics equipment are flat and unornamented.

Where included, broken lines showing environment or structure are for illustrative purposes only and form no part of the claimed design.

1 Claim, 12 Drawing Sheets

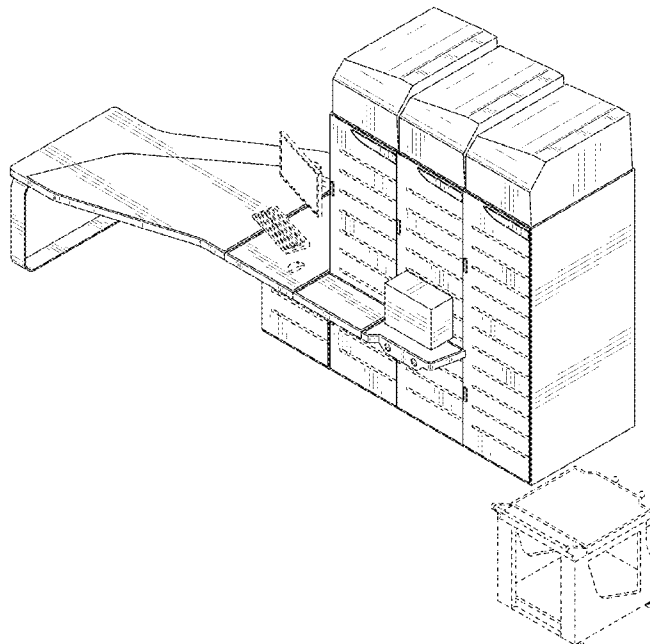

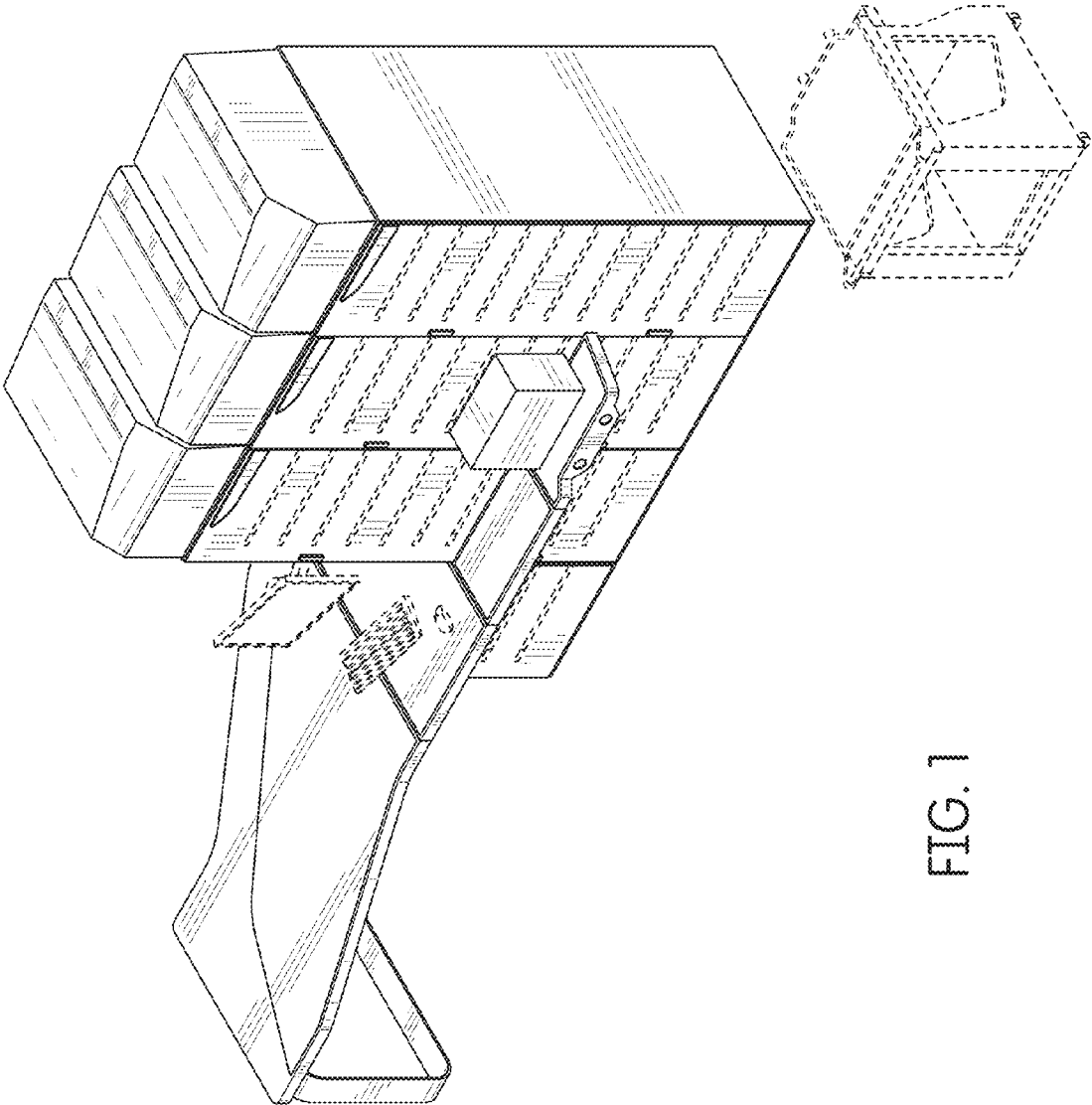

FIG. 1

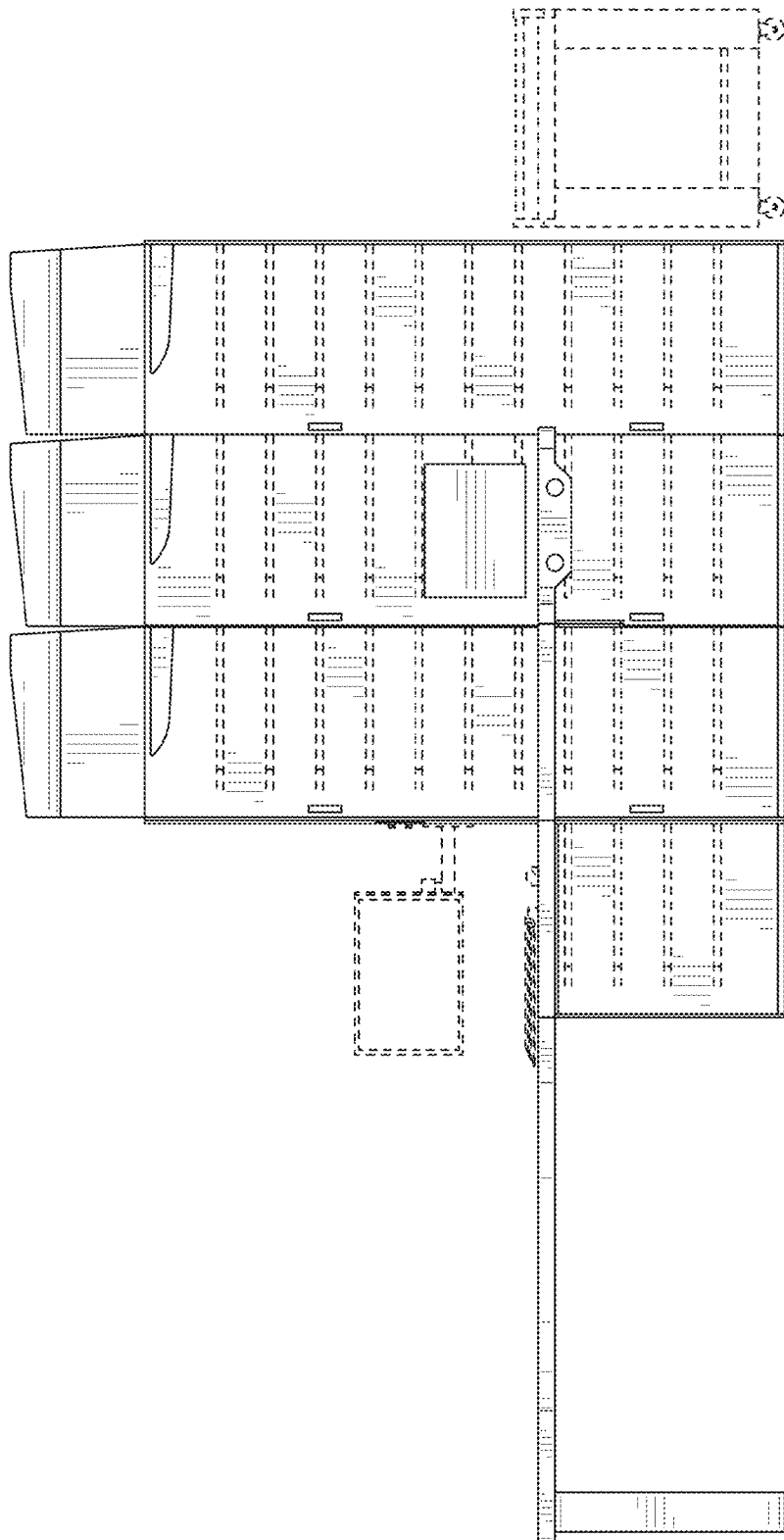

FIG. 2

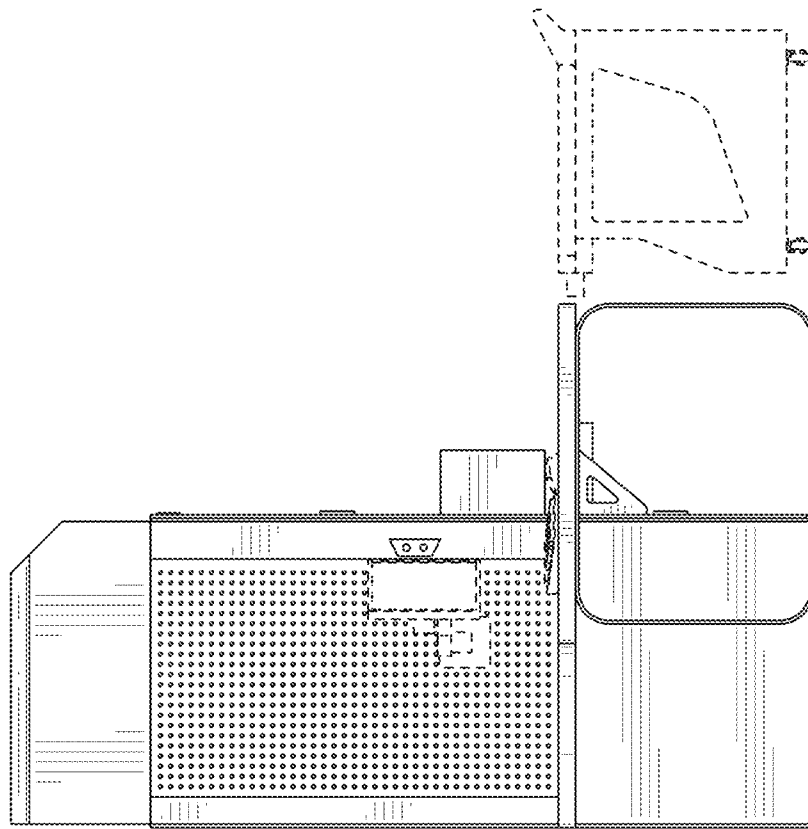

FIG. 3

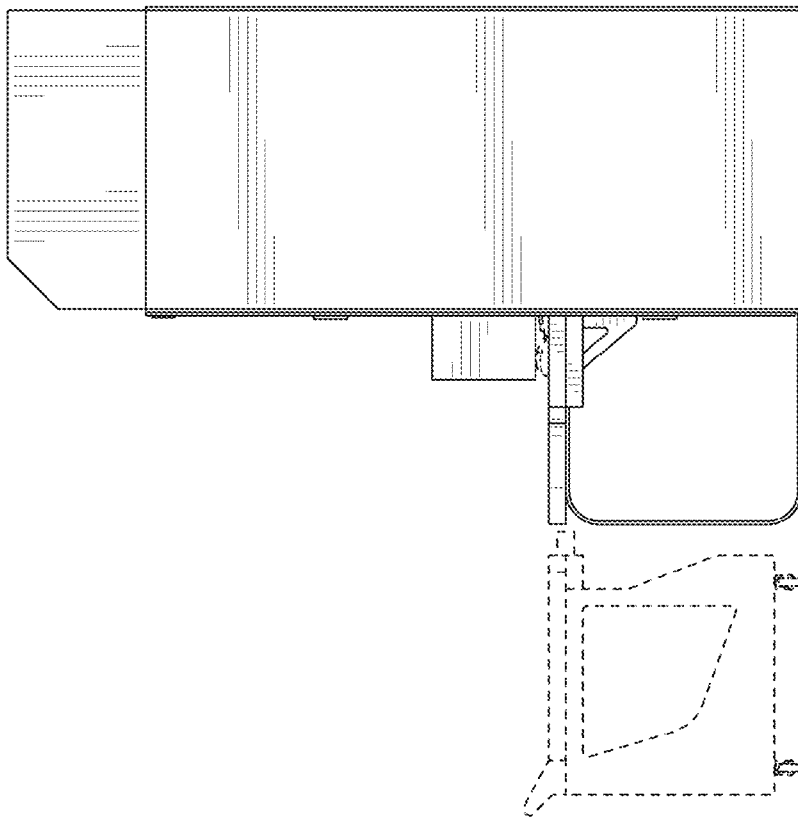

FIG. 4

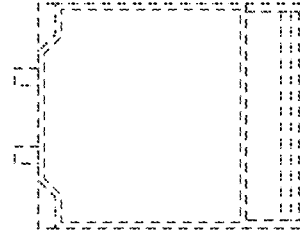
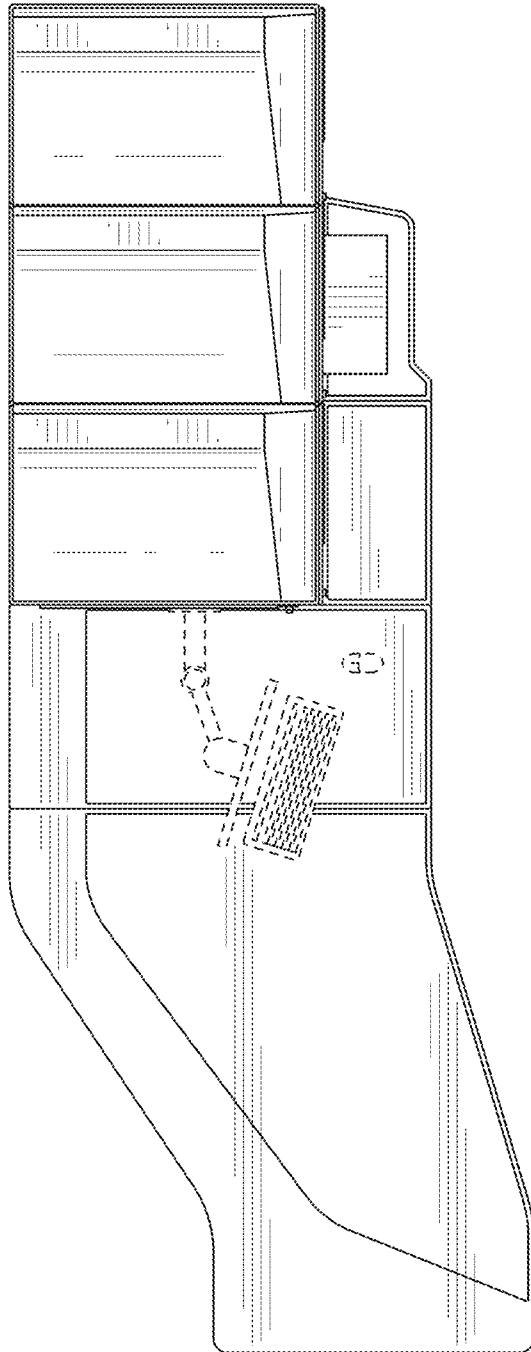

FIG. 5

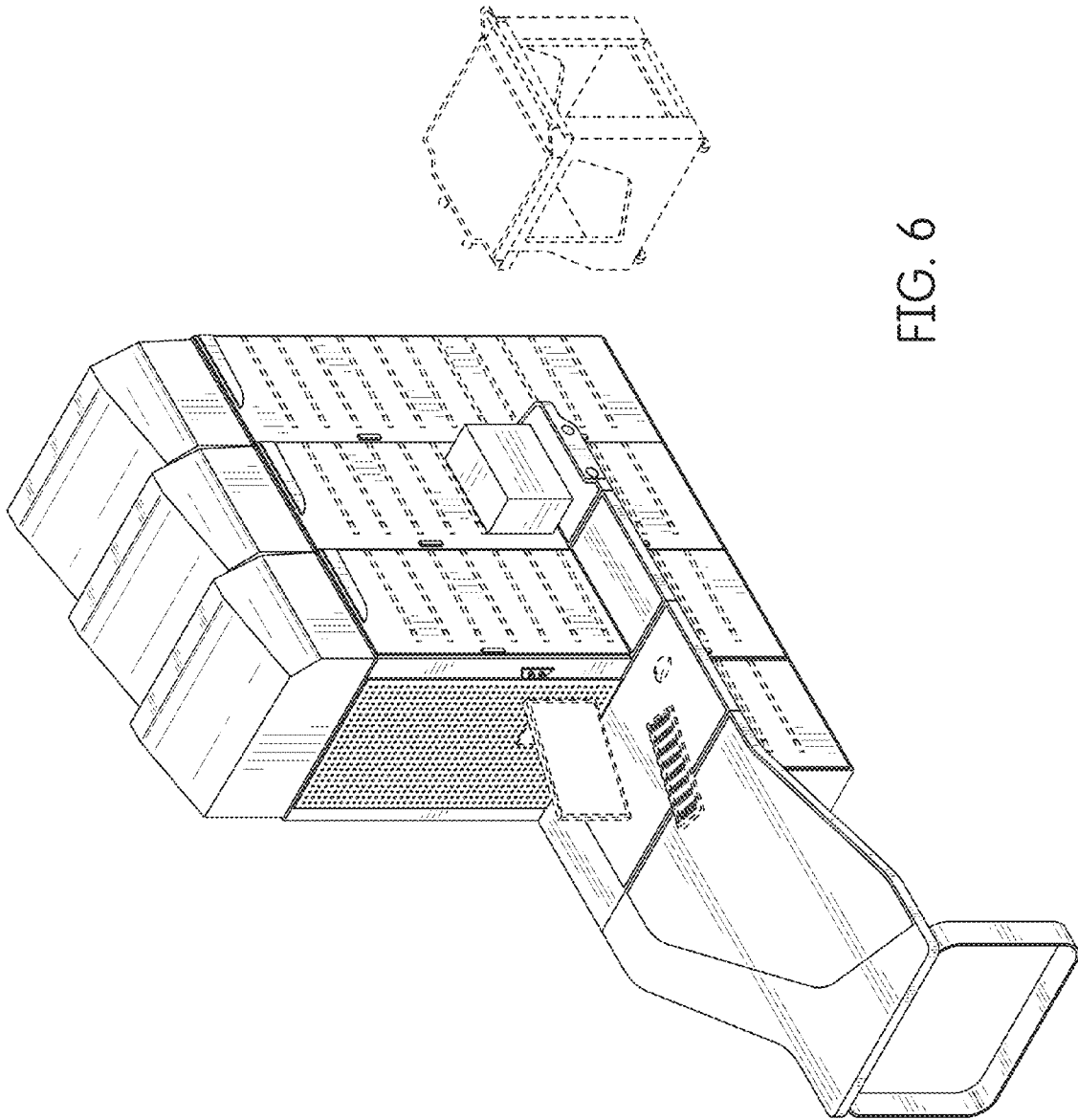

FIG. 6

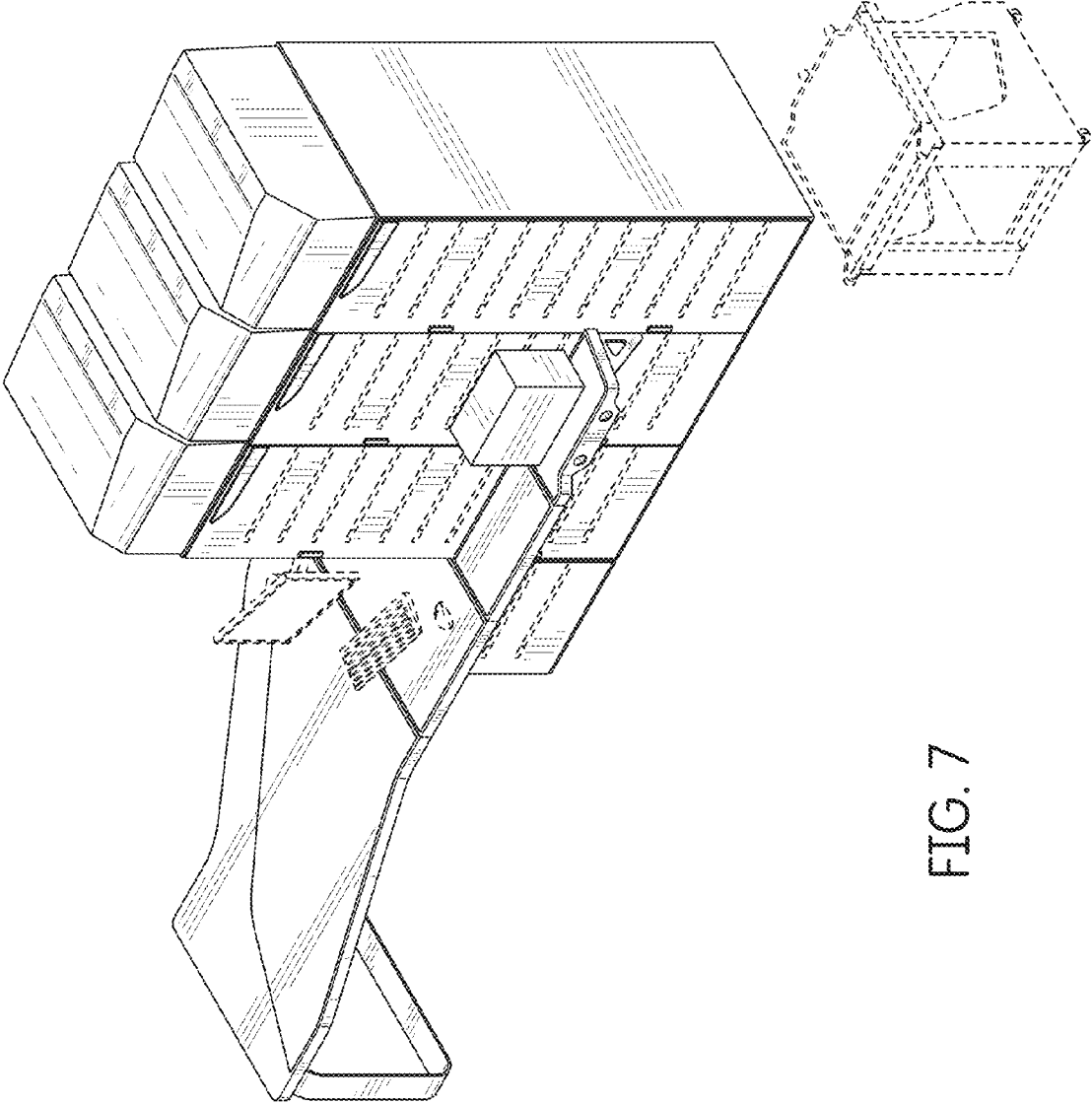

FIG. 7

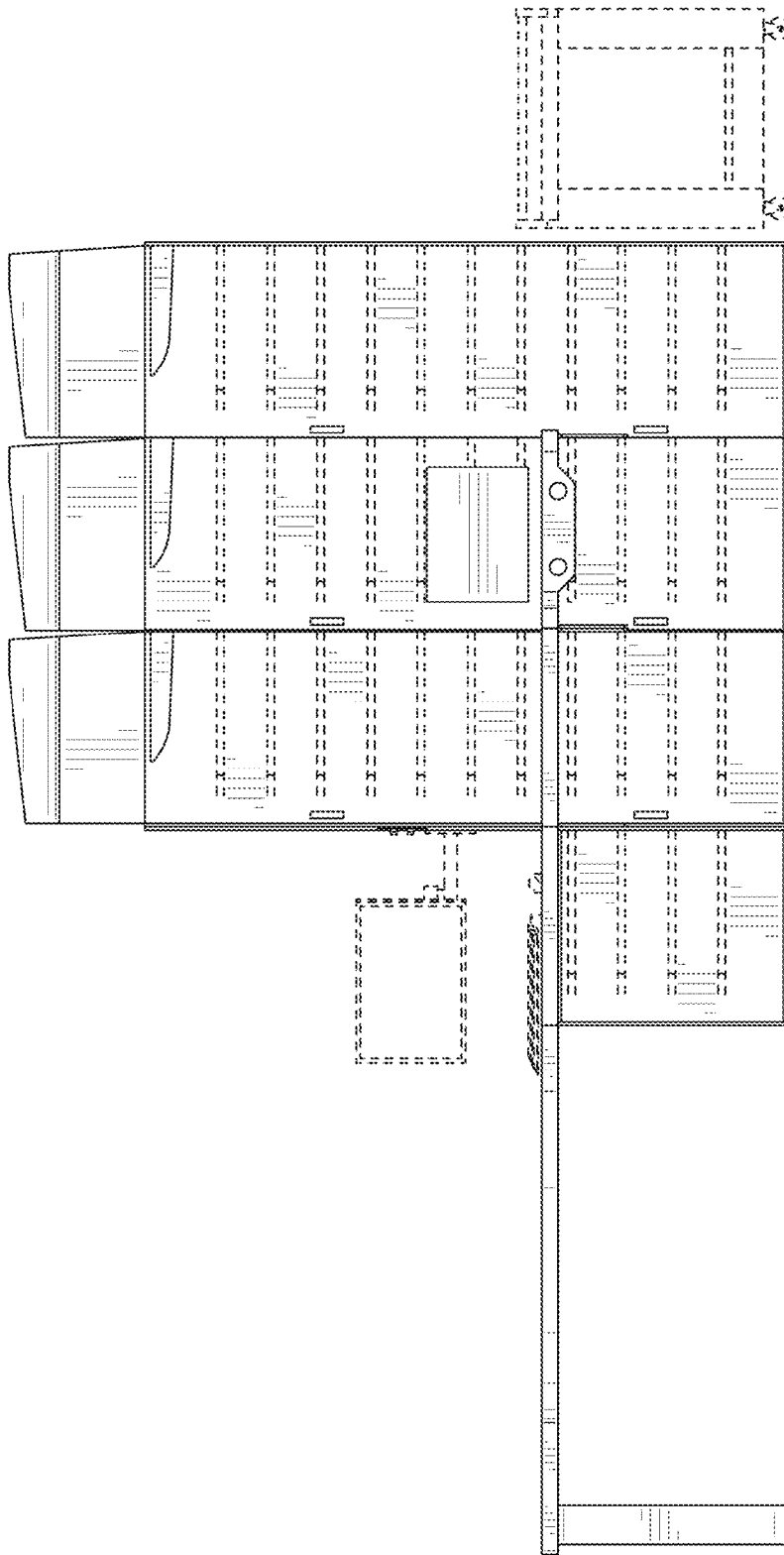

FIG. 8

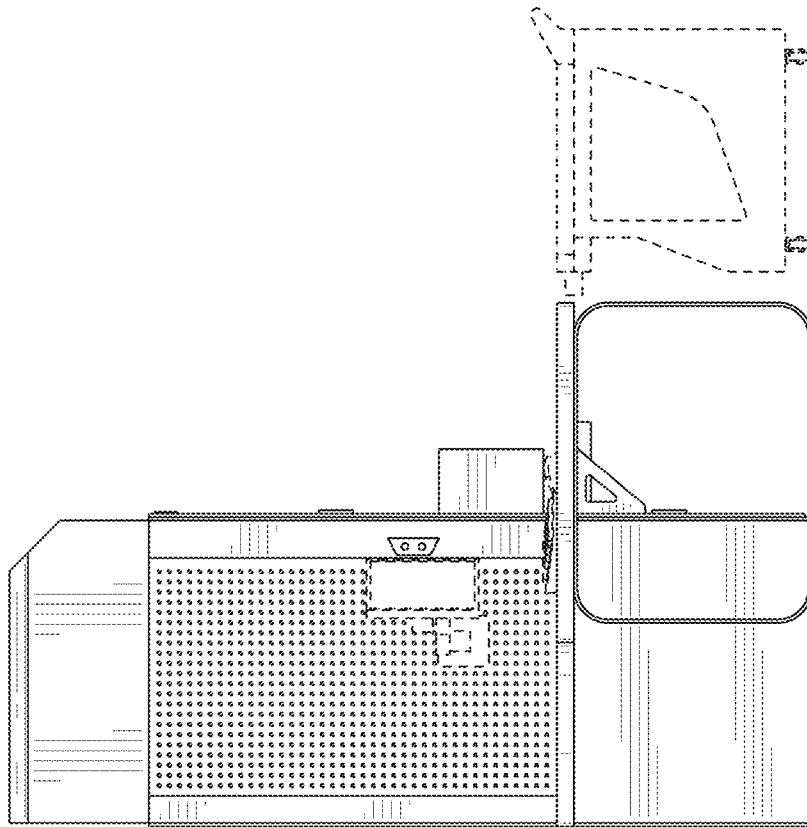

FIG. 9

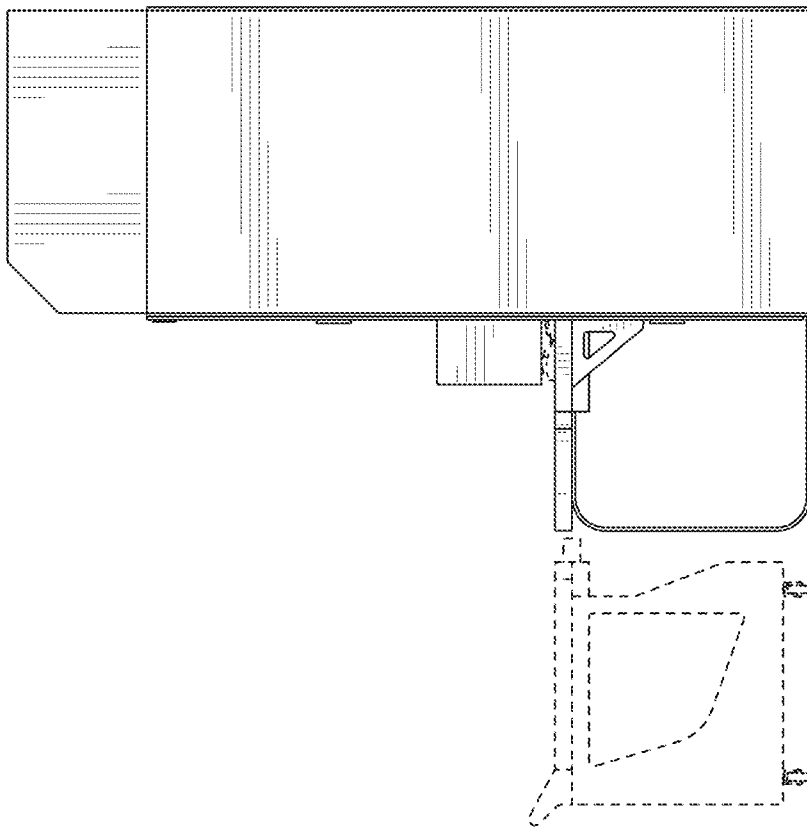

FIG. 10

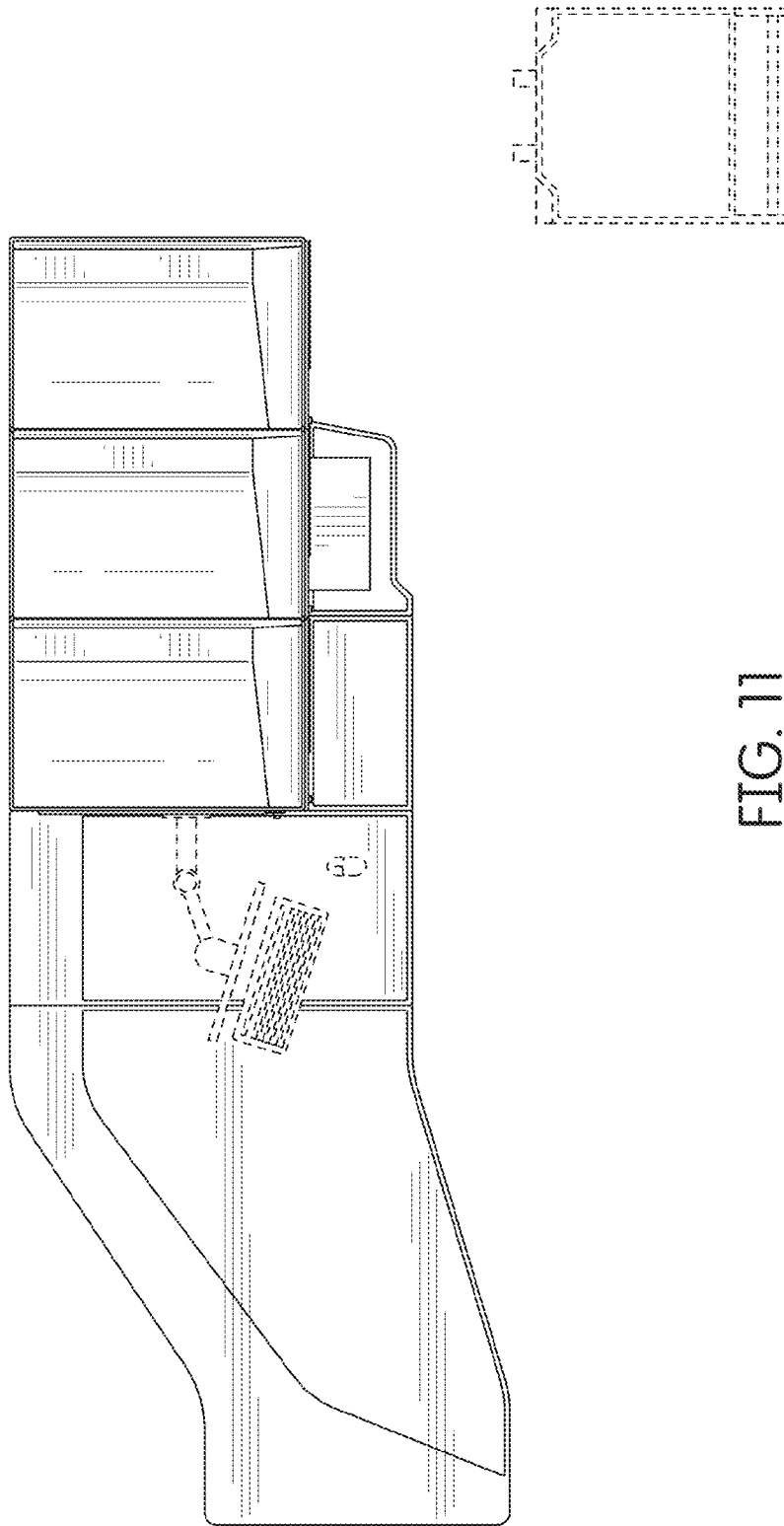

FIG. 11

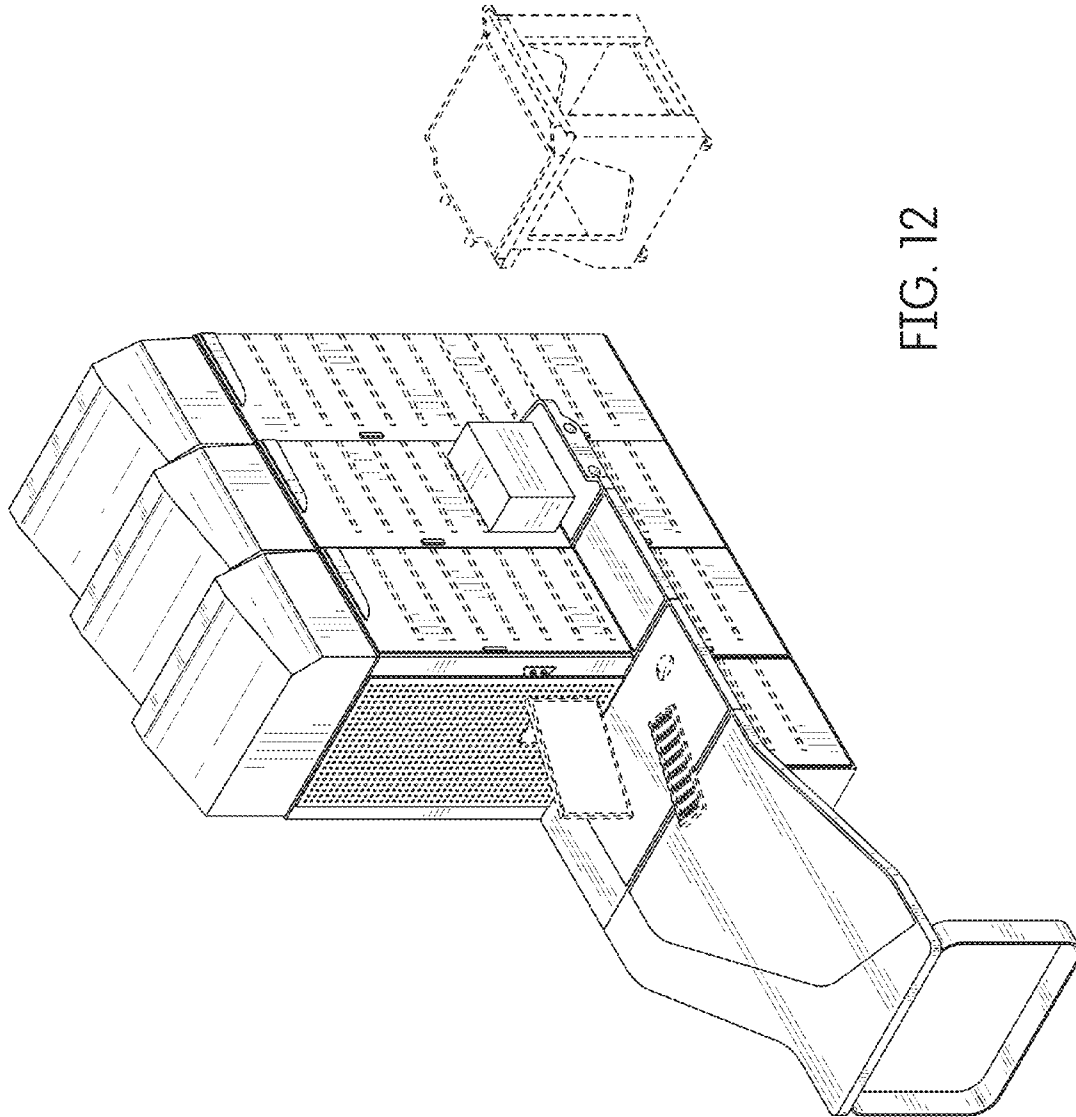

FIG. 12