

(19)  
(12)

(KR)  
(A)

(51) 。 Int. Cl.7  
H04B 7/26

(11)  
(43)

2003-0062524  
2003 07 28

(21) 10-2002-0002763  
(22) 2002 01 17

(71) 3 416

(72) 606 1305

(74)  
:

(54)

(CDMA)

가 PN

가

5

CDMA, slotted mode, paging channel

1

2

3 가 / -

4

5 가 / -

6



16

(slotted mode)

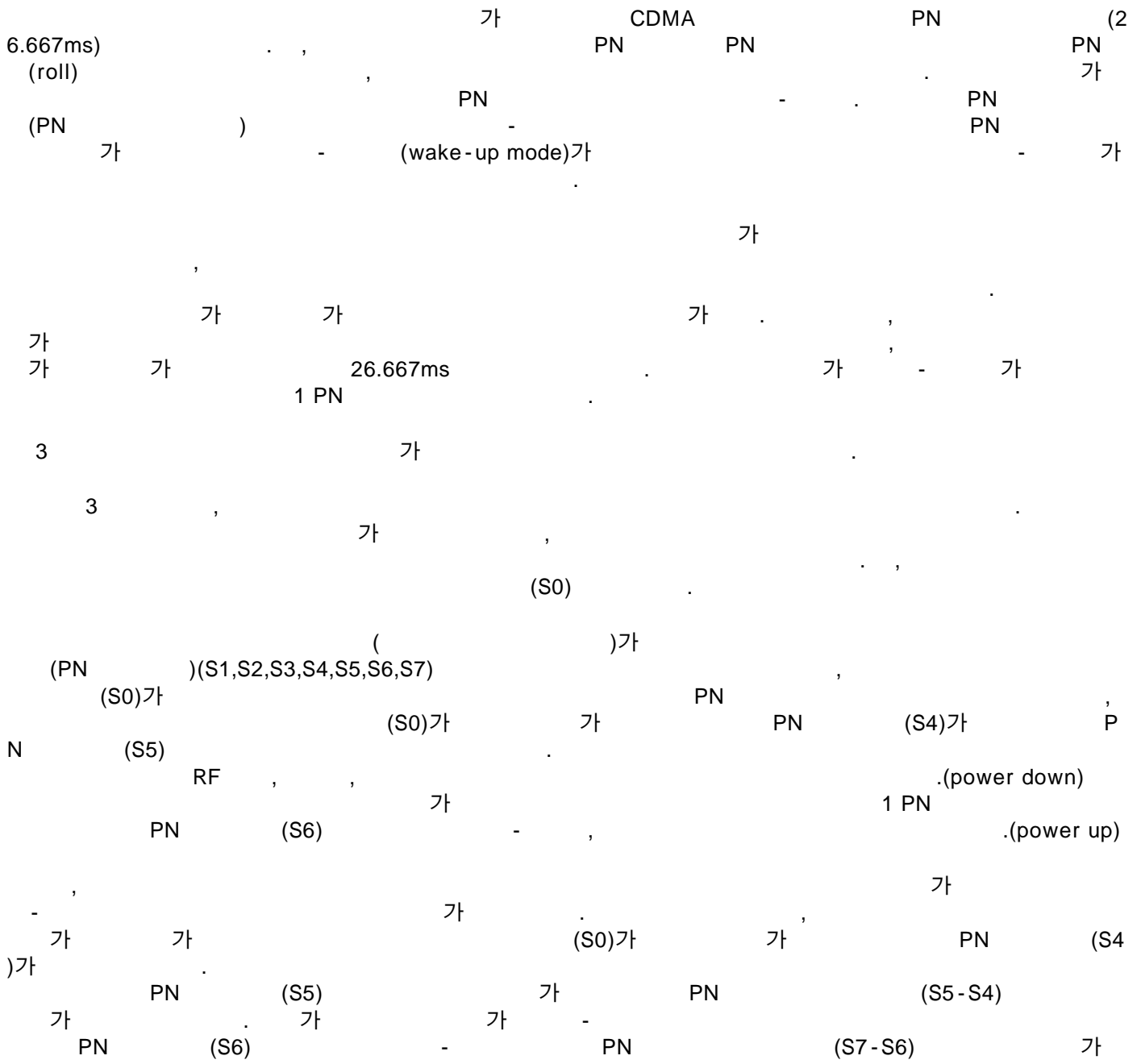

가 -

가

PN  
가

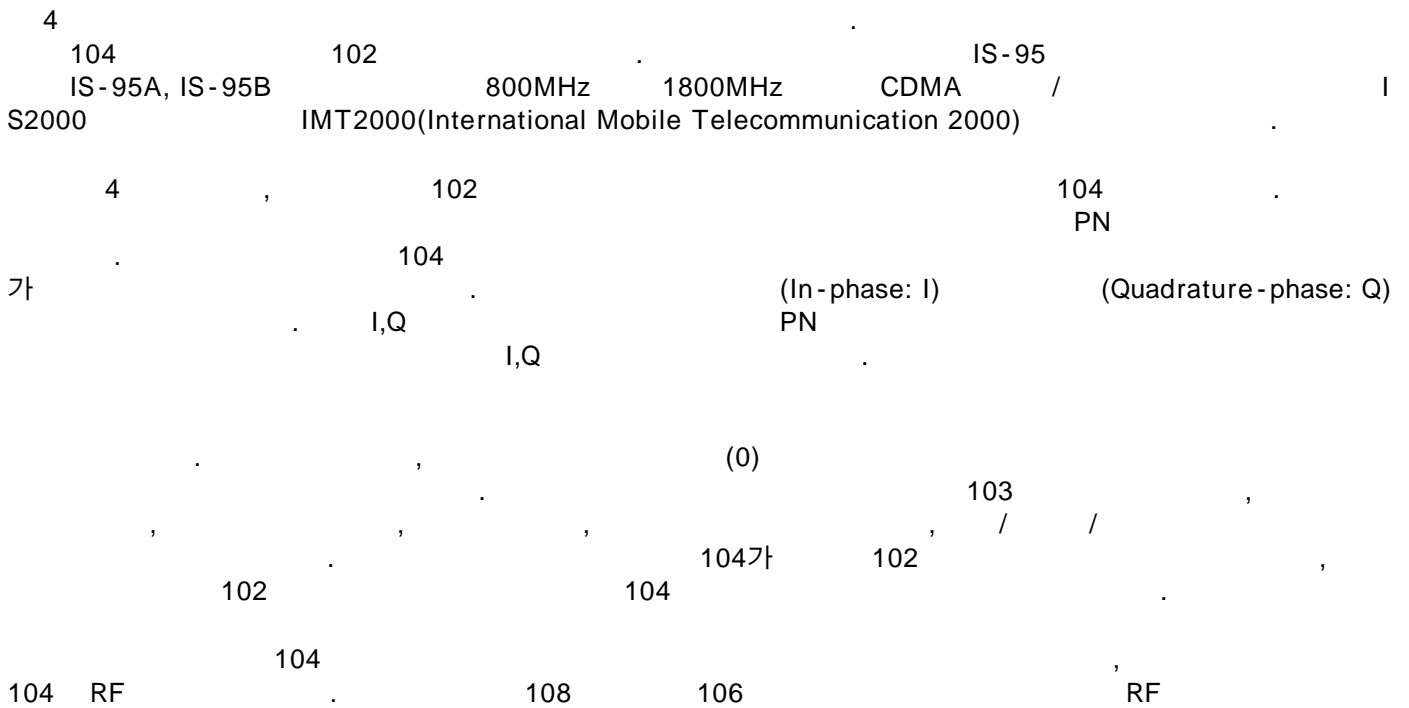

Converter: ADC) 110 RF / (Analog to Digital  
 114 116 / (ADC) 110 RF PN  
 ver) 112 114 (Receive Fingers) 122,124,126 116 (Rake Recei  
 122,124,126 / 110 가 PN ( (PN  
 114 ) 114 122,124,126 PN ( (PN  
 122,124,126 128 116 PN  
 가 - 116 128  
 가 108 / 110 112 114 12  
 8  
 가 / - 5  
 5 가 , - 가  
 116 가 (S0)  
 116 (S8)  
 (S8)가 PN (S5)  
 (S8) PN (S4)가 T2 T2 'PN  
 (26.667ms) - T1'가 T1  
 'T3' 116 - PN (S6)가  
 (S9) (26.667ms) - PN  
 1 PN (S6)가 'PN  
 (26.667ms) - T3' T2 , -  
 T3 , T2+T3  
 가 - 6  
 6 , 가  
 ,(S210) 가 ,(S220)  
 ,(S230) (S8) ,(power down)  
 ,(S240) 가 (S260)  
 가 / - PN  
 , 가 가 -  
 -  
 (S250) 5 7

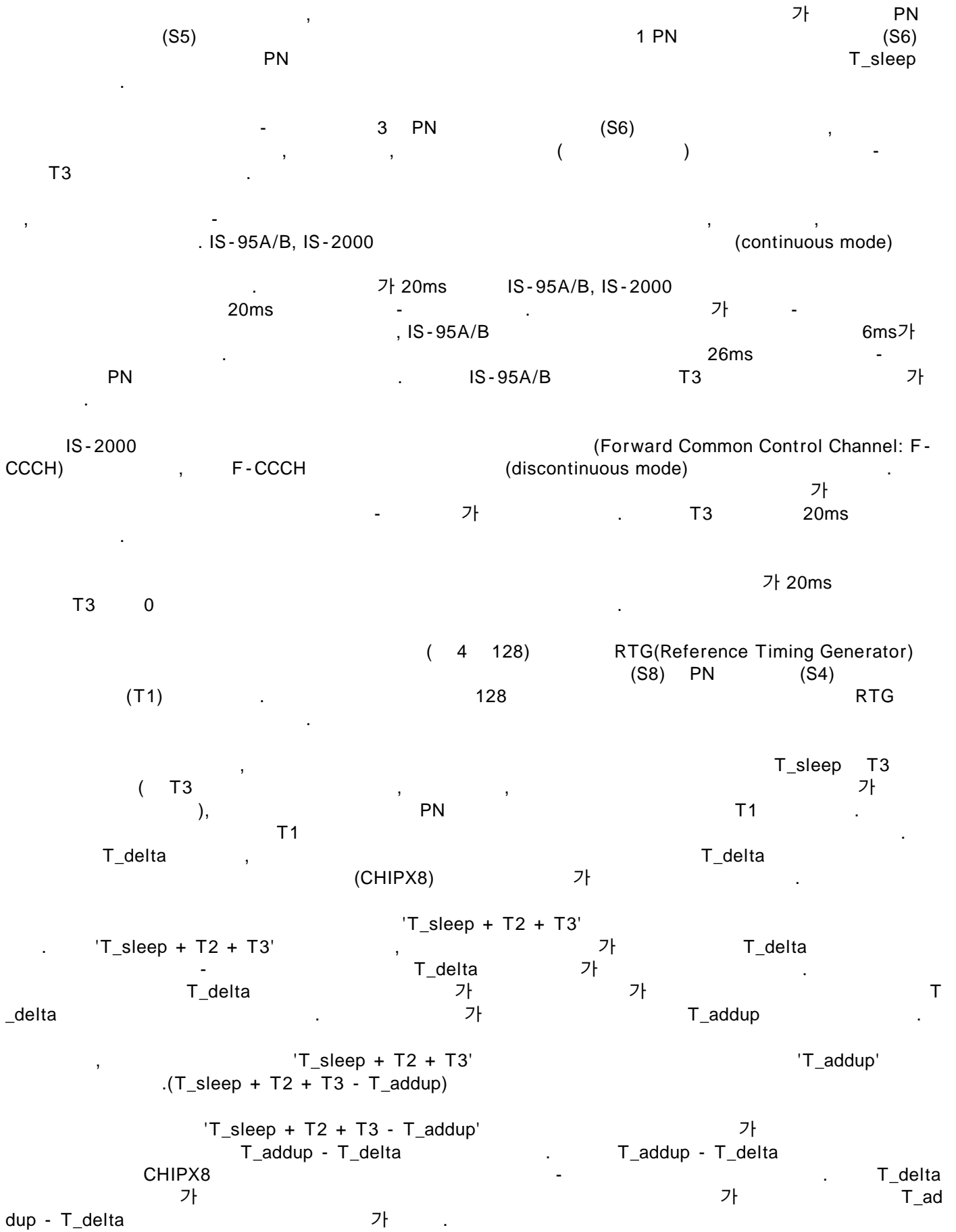



1

PN(Pseudo-random Noise)

가

T\_sleep

가

3.

2

4.

2

5.

6.

5

가

PN



1

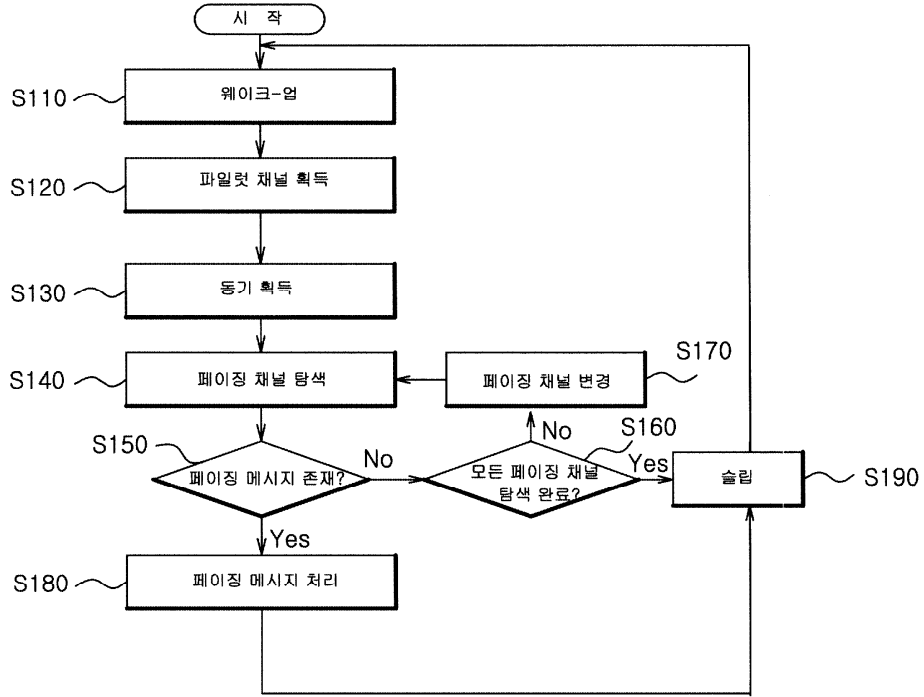

2

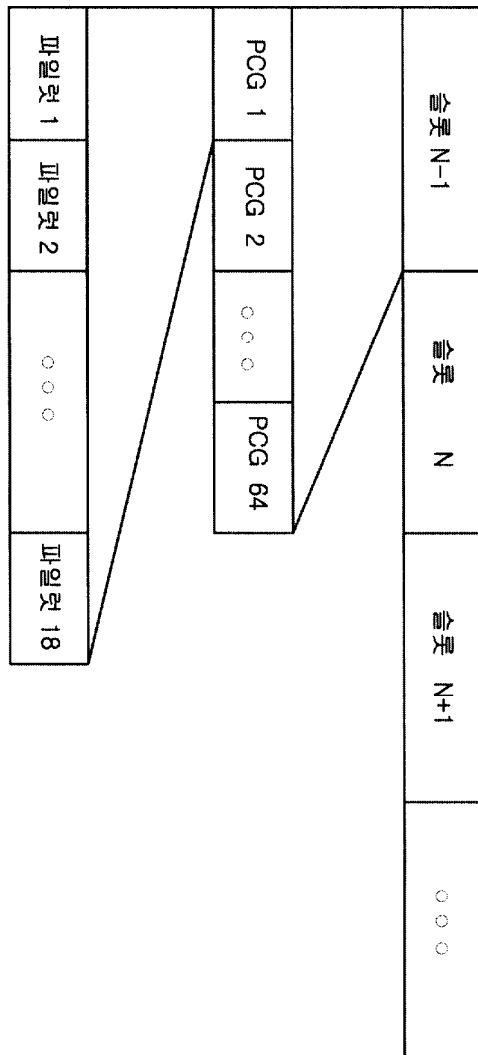

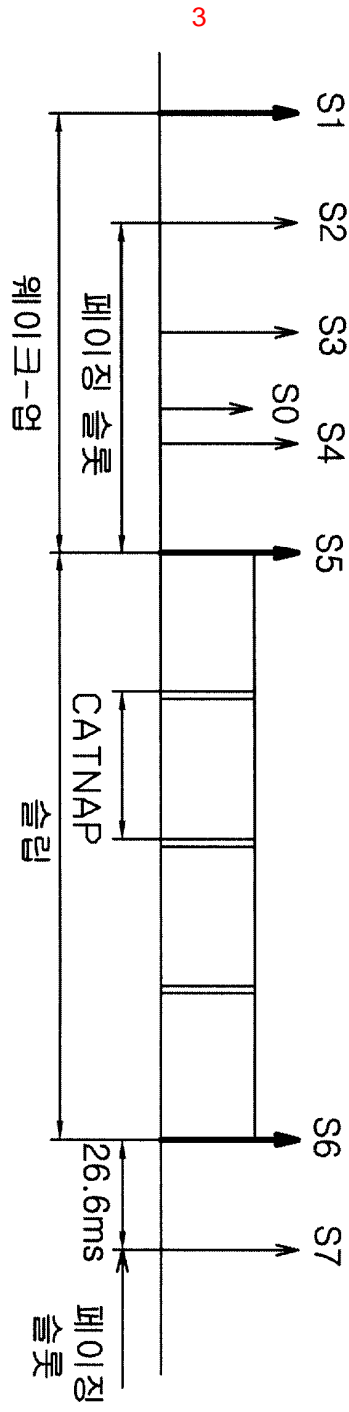

4

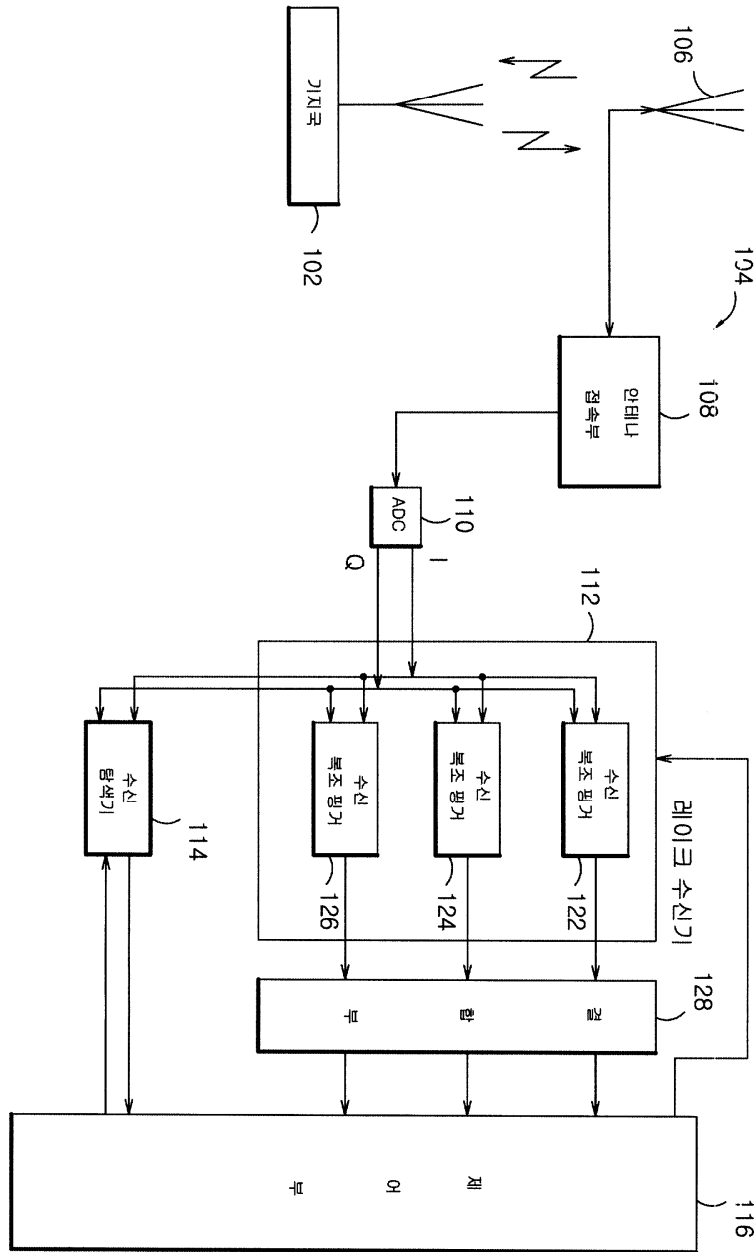

5

