

Service Manual

COMPACT SERIES

Applicable Models	Model Code	Applicable Models
HS-52FN	UR-BD40CM-ST	22031010002181

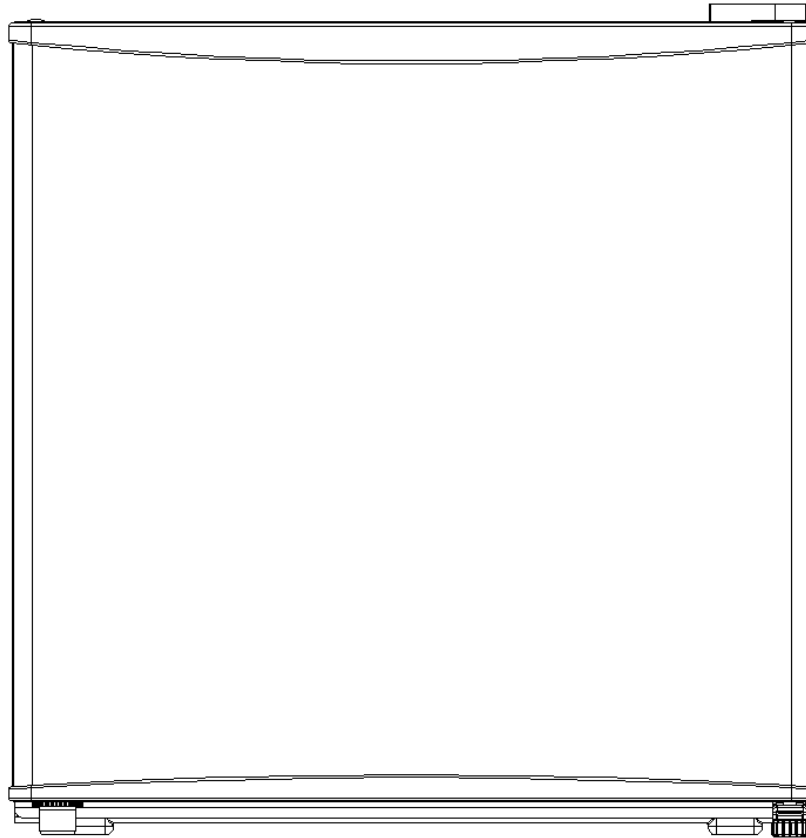

The picture in this service manual is only for reference, and specific appearance and configuration are subject to the real product.

This manual mainly teaches the method, the specific work skill needs engineer to accumulate through the daily work.

 **WARNING**

Important Safety Notice

There are special components used in this equipment which are important for safety. These parts are marked by  in the Schematic Diagrams, Circuit Board Diagrams, Exploded Views and Replacement Parts List. It is essential that these critical parts should be replaced with manufacturer's specified parts to prevent shock, fire or other hazards. Do not modify the original design without permission of manufacturer.

 **WARNING**

Important Safety Notice

The Maintenance Manual is only for the use of maintenance personnel with certain experience and background in electrical, electronic and mechanical field.

Any attempt to repair main devices may lead to personal injury and property loss.

Manufacturers or distributors are not responsible for the content of the Manual and interpretation thereof.

Midea Refrigerators

Technical Maintenance Manual

Copyright @2017

All rights reserved. Replication of all or part of the Manual in any forms shall not be allowed without written approval by the Overseas Sales Corporation of Midea Refrigerators.



Contents

1. SIGNIFICANT UPDATE NOTES(NONE)	5
2. SAFETY WARNING CODE	6
2.1 WARNING FOR OPERATION SAFETY	6
2.2 SAFETY INSTRUCTION FOR REFRIGERANT	8
3. TRANSPORT	9
3.1 HANDLING.....	9
4. INSTALLATION AND COMMISSIONING	10
4.1 DOOR DISASSEMBLY AND ASSEMBLY(NONE)	10
4.2 INSTALLATION LOCATION	10
4.3 LEVELING OF THE REFRIGERATOR	10
4.4 LEFT OR RIGHT OPEN DOOR REVERSAL	11
4.5 INSTALLATION OF HANDLE (NONE)	12
4.6 INSTALLATION OF DOOR LOCK (NONE)	12
5. PRODUCT CONFIGURATION AND DIMENSION	13
5.1 MAIN PARTS AND THEIR NAMES	13
5.2 EXTERNAL DIMENSION.....	13
5.3 LOCATION OF S/N	15
6. PRODUCT SPECIFICATION	16
6.1 ELECTRICAL PARAMETERS	16
6.2 COOLING TEMPERATURE SETTING RANGE	16
6.3 CIRCUIT DIAGRAM	17
7. REFRIGERATING PIPING SYSTEM AND CIRCULATING ROUTE OF COOLING AIR	18
7.1 REFRIGERATING PIPING SYSTEM.....	18
7.2 SPECIAL SOLDERING POSITION	18
8. DISMANTLING OF PARTS	19
8.1 PARTS ON THE DOOR.....	19
8.2 PARTS INSIDE THE REFRIGERATOR	19
8.3 LIGHT SYSTEM.....	20
8.4 EVAPORATOR AND DEFROST SYSTEM.....	20
8.5 COMPRESSOR CASE.....	20
8.6 DISPLAY CONTROL BOARD (NONE)	24
9. TEMPERATURE SENSING SYSTEM	25
9.1 THERMOSTAT	25
10. FUNCTION AND OPERATION	26
10.1 OPERATION PANEL	26





10.2 TEMPERATURE SETTING.....	26
10.3 OPEN DOOR ALARM(NONE)	26
10.4 DEFROSTING FUNCTION.....	26
11. COMPRESSOR.....	27
11.1COMPRESSOR ON AND OFF CONTROL SPECIFICATIONS.....	27
12. TROUBLESHOOTING METHOD.....	28
12.1NOT COOLING	28
12.2 NO WORKING OF COMPRESSOR.....	29
12.3THERMOSTAT MALFUNCTION-UNDERCOOLING.....	29
12.4 INSIDE FROSTING, NO DEFROSTING.....	30
12.5 INSIDE FROSTING, NO DEFROSTING-MAINTENANCE GUIDELINES.....	30
12.6 LIGHT IS NOT ON.....	31
12.7 NOISE.....	32
13. FIGURES AND DETAILS OF REPAIR PARTS.....	33

1. Significant update notes(None)

2. Safety Warning Code

2.1 Warning for operation safety

Important Safety Instructions

	CAUTION RISK OF ELECTRIC SHOCK DO NOT OPEN	
	This symbol indicates that dangerous voltage constituting a risk of electric shock is present within your freezer.	
	This symbol indicates that there are important operating and maintenance instructions in the literature accompanying your freezer.	

WARNING

- 1) Read these instructions.
- 2) Keep these instructions.
- 3) Heed all warnings.
- 4) Follow all instructions.
- 5) Do not use this appliance near water.
- 6) Clean only with a damp cloth.
- 7) Do not block any ventilation openings.
- 8) Install in accordance with the manufacturer's instructions.
- 9) Do not install near any heat sources, such as radiators, heat registers, stoves, or other apparatus that produce heat.
- 10) Do not defeat the safety purpose of the polarized or grounding-type plug. A polarized plug has two blades with one wider than the other. A grounding type plug has two blades and a third grounding prong. The wide blade or the third prong are provided for your safety. If the provided plug does not fit into your outlet, consult an electrician for replacement of the obsolete outlet.
- 11) Protect the power cord from being walked on or pinched, particularly at plugs, convenience receptacles, and the point where they exit from the appliance.
- 12) Do not attempt to modify or extend the power cord of this appliance.
- 13) Unplug this appliance during lightning storms or when it will not be used for long periods of time.
- 14) Make sure that the available AC power matches the voltage requirements of this appliance.

CONNECTING ELECTRICITY

**WARNING****Electrical Shock Hazard.**

Plug into a grounded 3-prong outlet.
Do not remove the ground prong.
Do not use an adapter.

Failure to follow these instructions can result in death, fire, or electrical shock.

**WARNING****Electric Shock Hazard**

Failure to follow these instructions can result in electric shock, fire, or death.

- 1) **WARNING**—Keep ventilation openings, in both the freezer and the built-in structure, clear of obstruction.
- 2) **WARNING**—Do not touch the interior of the freezer with wet hands. This could result in frost bite.
- 3) **WARNING**—Do not use mechanical devices or other means to accelerate the defrosting process, other than those recommended by the manufacturer.
- 4) **WARNING**—Do not damage the refrigerant circuit.
- 5) **WARNING**—Do not damage the refrigerant tubing when handling, moving, or using the freezer.
- 6) **WARNING—DANGER**—Never allow children to play with, operate, or crawl inside the freezer. Risk of child entrapment. Before you throw away your old freezer:
 - 6-1) Take off the doors
 - 6-2) Leave the shelves in place so that children may not easily climb inside
- 7) Unplug the freezer before carrying out user maintenance on it.
- 8) This freezer can be used by children age eight years and older and persons with reduced physical or mental capabilities or lack of experience and knowledge if they are given supervision or instruction concerning the use of the freezer in a safe way and understand the hazards involved. Children should not play with the freezer. Cleaning and maintenance should not be performed by children without supervision.
- 9) If a component part is damaged, it must be replaced by the manufacturer, its service agent, or similar qualified persons in order to avoid a hazard.
- 10) Please dispose of the freezer according to local regulations as the freezer contains flammable gas and refrigerant.
- 11) Follow local regulations regarding disposal of the freezer due to flammable refrigerant and gas. All refrigeration products contain refrigerants, which under the guidelines of federal law must be removed before disposal. It is the consumer's responsibility to comply with federal and local regulations when disposing of this product.
- 12) This freezer is intended to be used in household and similar environments.

13) Do not store or use gasoline or any flammable liquids inside or in the vicinity of this freezer.

14) Do not use extension cords or ungrounded (two-prong) adapters with this freezer. If the power cord is too short, have a qualified electrician install an outlet near the freezer. Use of an extension cord can negatively affect the freezer's performance.

Grounding requirement

This freezer must be grounded. This freezer is equipped with a cord having a grounding wire with a grounding plug. The plug must be inserted into an outlet that is properly installed and grounded.

Improper use of the grounding plug can result in a risk of electric shock. Consult a qualified electrician or service person if the grounding instructions are not completely understood, or if doubt exists as to whether the freezer is properly grounded.

2.2 Safety instruction for refrigerant

 **WARNING**



Explosion Hazard.

Keep flammable materials and vapors, such as gasoline, away from freezer. Failure to do so can result in fire, explosion, or death.



Safety instruction for refrigerant

DANGER—Risk of Fire or Explosion. Flammable Refrigerant Used. To Be Repaired Only By Trained Service Personnel. Do Not Use Mechanical Devices. Do Not Puncture Refrigerant Tubing. CAUTION—Risk of Fire or Explosion. Flammable Refrigerant Used. Consult Repair Manual/Owner's Guide Before Attempting To Service This Product. All Safety Precautions Must be Followed. CAUTION—Risk of Fire or Explosion. Dispose of Properly In Accordance With Federal Or Local Regulations. Flammable Refrigerant Used. CAUTION—Risk of Fire or Explosion Due To Puncture Of Refrigerant Tubing; Follow Handling Instructions Carefully. Flammable Refrigerant Used.

3. Transport

3.1 Handling

Handling

- 1)Protect the refrigerator in moving it,Same as shown as left photo, please move it by handcart with cushion
- 2)Remove all packing materials and bottom cushion, then move into house for placement
- 3)After moving it to appropriate location, wait for 2 hours before power on.

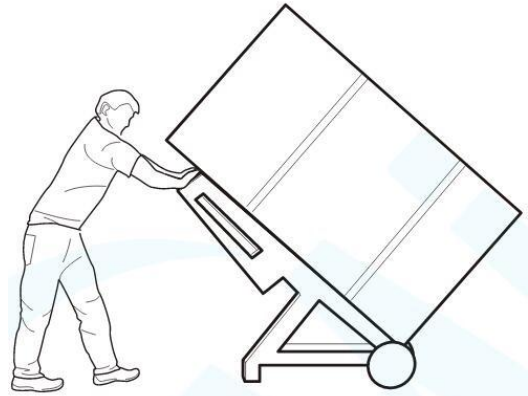

4. Installation and commissioning

4.1 Door Disassembly and Assembly(None)

The refrigerator door needs to be dismantled if it cannot enter the room in the whole.

4.2 Installation location

Installation location

Location that is easy for ventilation shall be chosen to facilitate heat dissipation, enhance its performance and reduce the energy consumption.

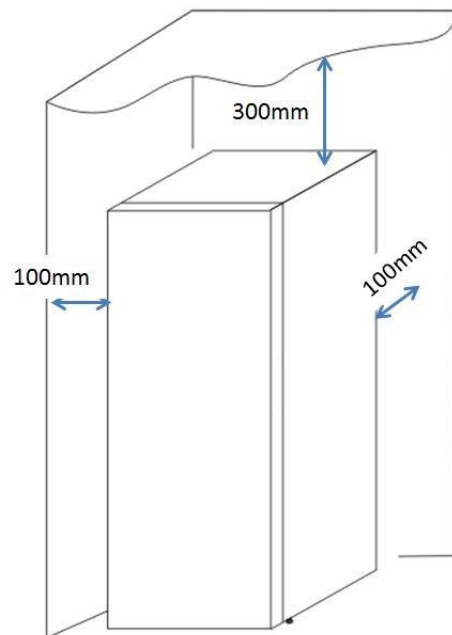

4.3 Leveling of the refrigerator

Leveling of the refrigerator

If the refrigerator cannot be placed steadily, adjust the footing to level it.

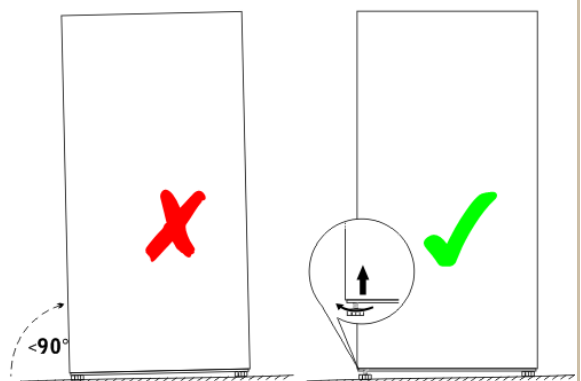

4.4 Left or right open door reversal

Door reversal

1) Unplug your refrigerator and remove all food from the door shelves.

2) Remove the left cover plate and the right top hinge cover, then unscrew and remove the right top hinge. Keep the screws to reuse

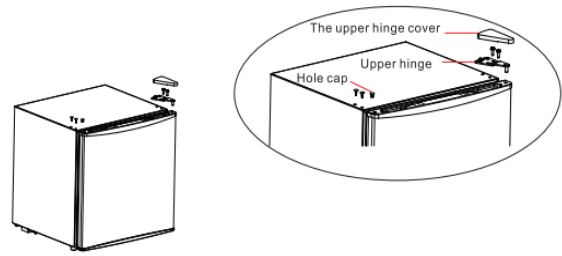

3) Put on the cushion block, lie down the refrigerator, remove the 3 bolts fixed the lower hinge with the sleeve, remove the lower hinge and adjust the foot.

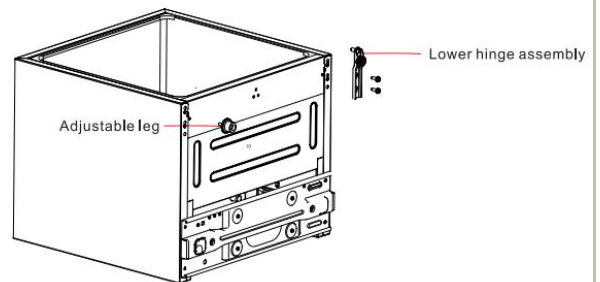

4) Remove the door block from the bottom, right side of the door and attach it to the other side.

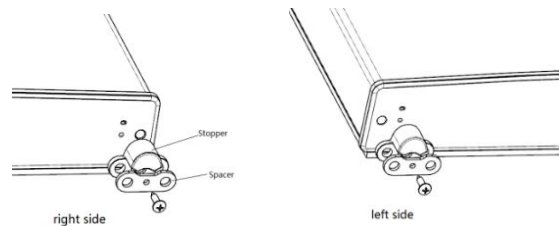

5) Fix the lower hinge on the left side of the refrigerator with the bolts and adjust the foot to the right side.

6) Place the refrigerator door vertically on the lower hinge shaft in the open door state.

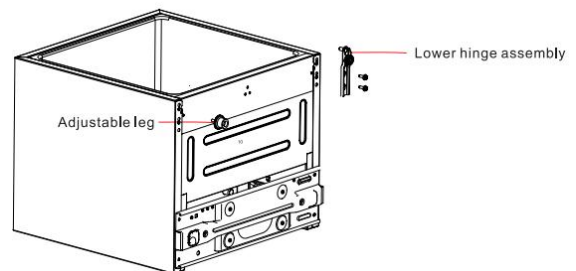

7) attach the top left hinge to the top of refrigerator. Cover the hinge with the top left hinge cover and cover the screw holes on the right side of the top with the cover plate you previously removed.

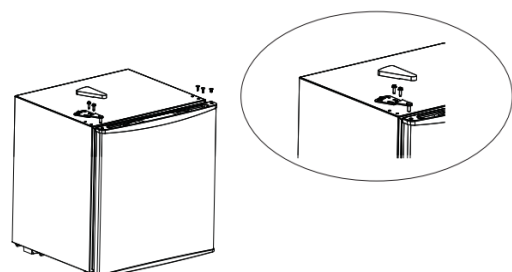

4.5 Installation of handle (None)

4.6 Installation of door lock (None)

5. Product configuration and dimension

5.1 Main parts and their names



(The picture is only for reference, and specific appearance and configuration are subject to the real product)

Freezer chamber	Refrigerator chamber
1.Rack 2.Temperature control rotary knob assembly 3.Tray	None

5.2 External dimension

Description	Code	Size (mm)
Height to Top of Case	A	492
Width	B	472
Depth w/Cabinet	C	390
Depth w/Door	D	450
Depth w/Handle	E	/
Depth (Door open 90 deg. w)	F	877
Depth (Door open 135 deg. w)	G	810
Width (Door open 135 deg. w)	H	790

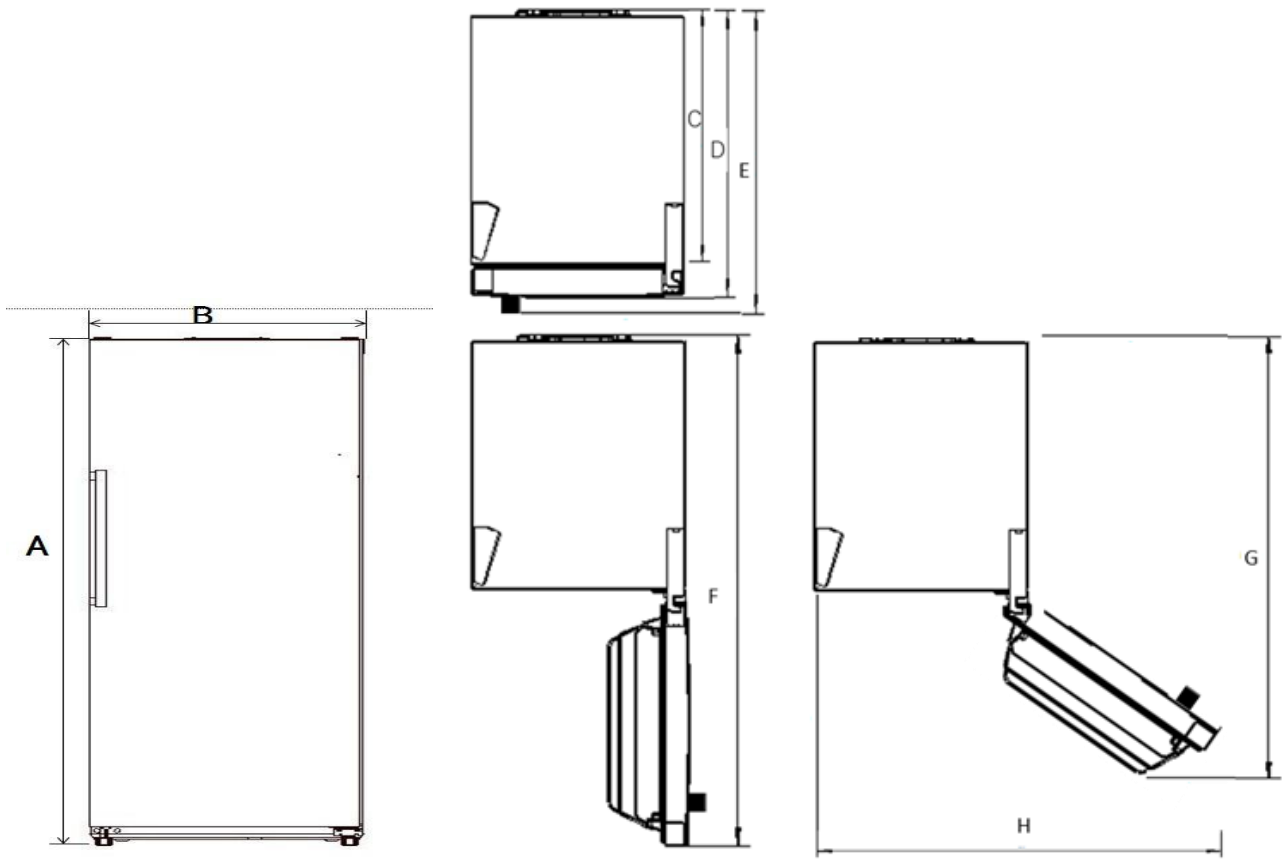

(The picture is only for reference)

5.3 Location of S/N

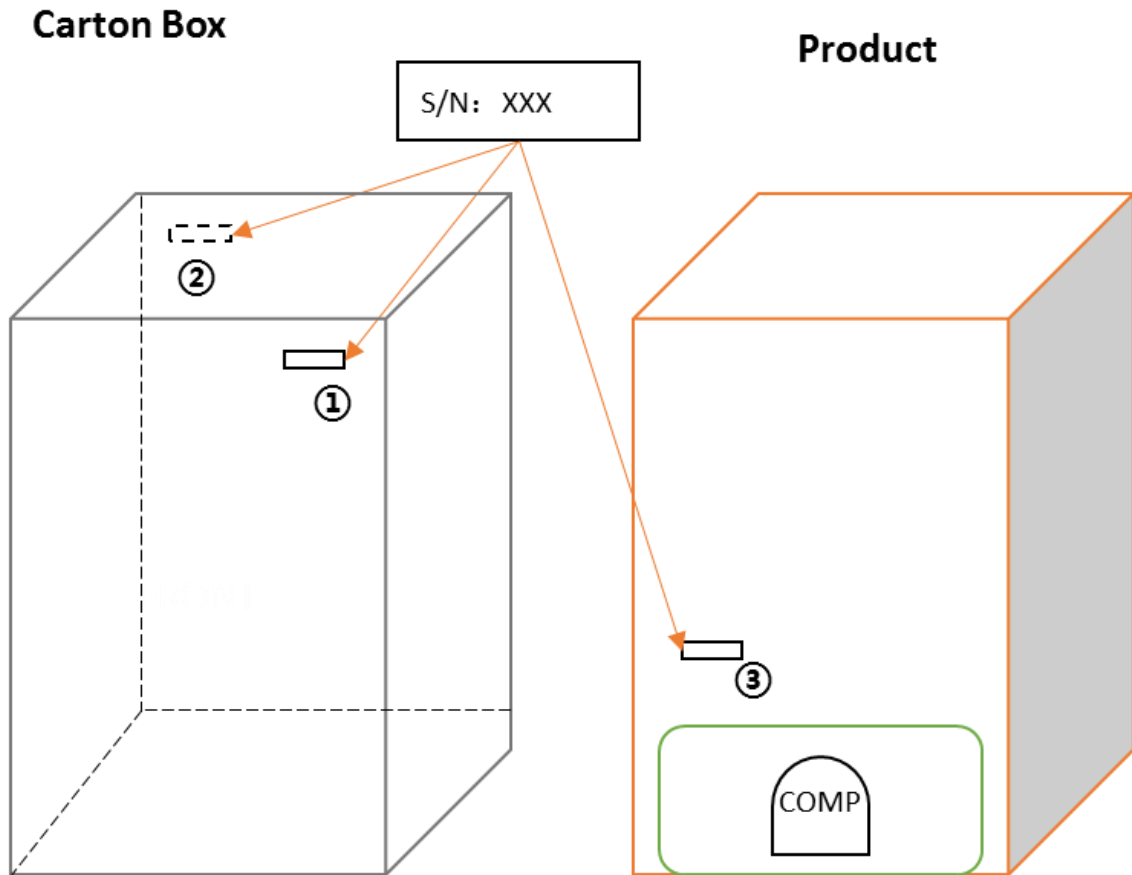

Some products also have S/N on the lower part of the right side of the Cabinet.

6. Product specification

6.1 Electrical parameters

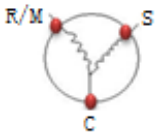
Applicable Models	HS-52FN
Product Name	UR-BD40CM-ST
Product Code	22031010002181
Item	Specification
Refrigerant	R600a
Compressor	FZ35C1M
Starter(PTC)	QP2-4R7
Overload protector(OLP)	DRB18T61A1
Integrate PTC+OLP	None
Variable frequency driver board	None
Capacitor	None
Power filter	None
Winding resistance of compressor wiring terminal	R _{mc} : 13.7±7%Ω R _{sc} : 13.0±7%Ω R _{ms} =R _{mc} +R _{sc}
Winding resistance picture	
The input power of compressor	
Lights inside the refrigerator	
Lights inside the refrigerating chamber	None
Switch of the refrigerator door	None

6.2 Cooling temperature setting range

Compartment	The highest (°C)	Lowest (°C)
Freezing	-12	-24
Refrigerating	/	/

6.3 Circuit diagram

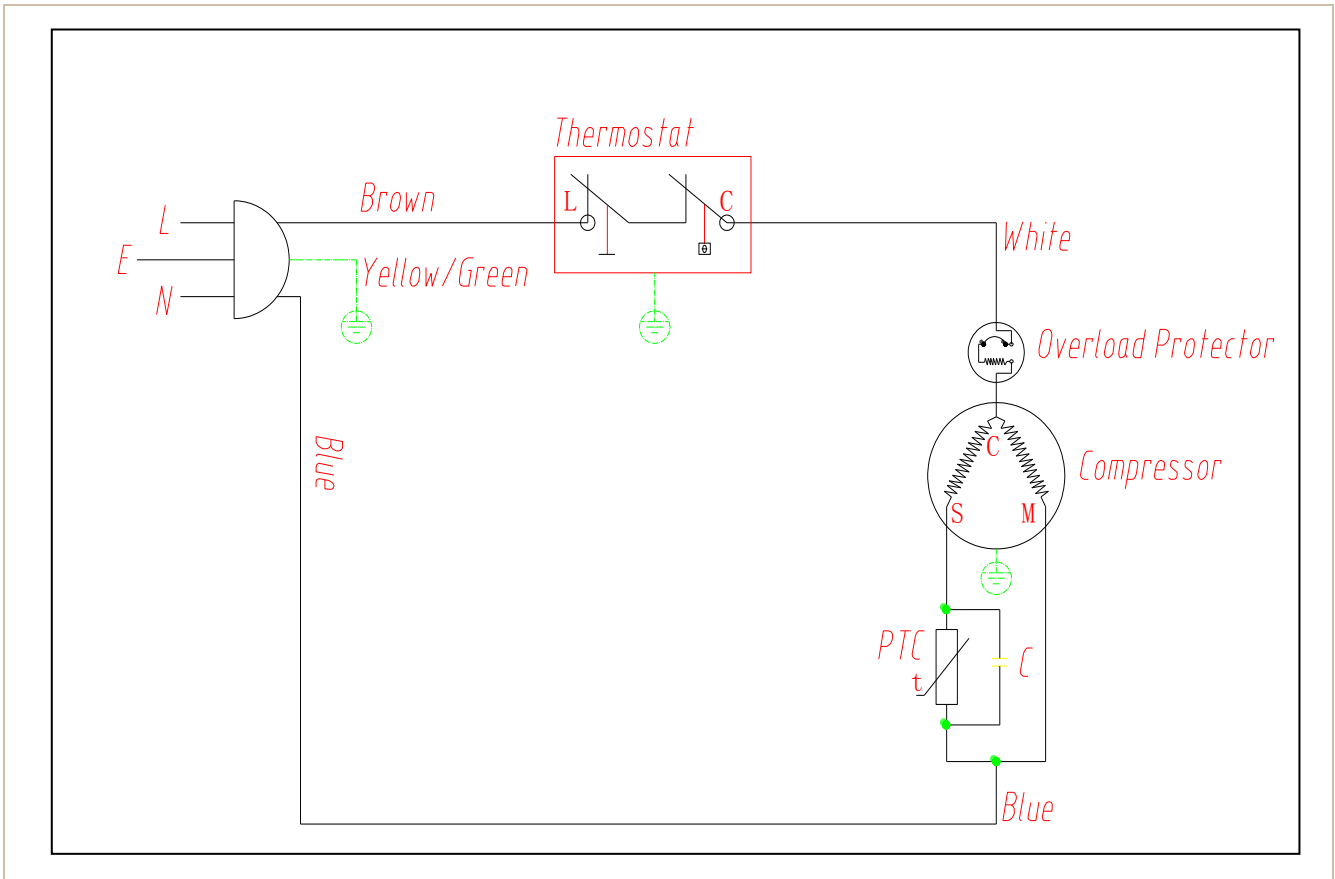

7.Refrigerating piping system and circulating route of cooling air

7.1 Refrigerating piping system

Compressor---Right condenser ---Left condenser---Dry filter---Capillary tube---F evaporator---Suction tube---Compressor

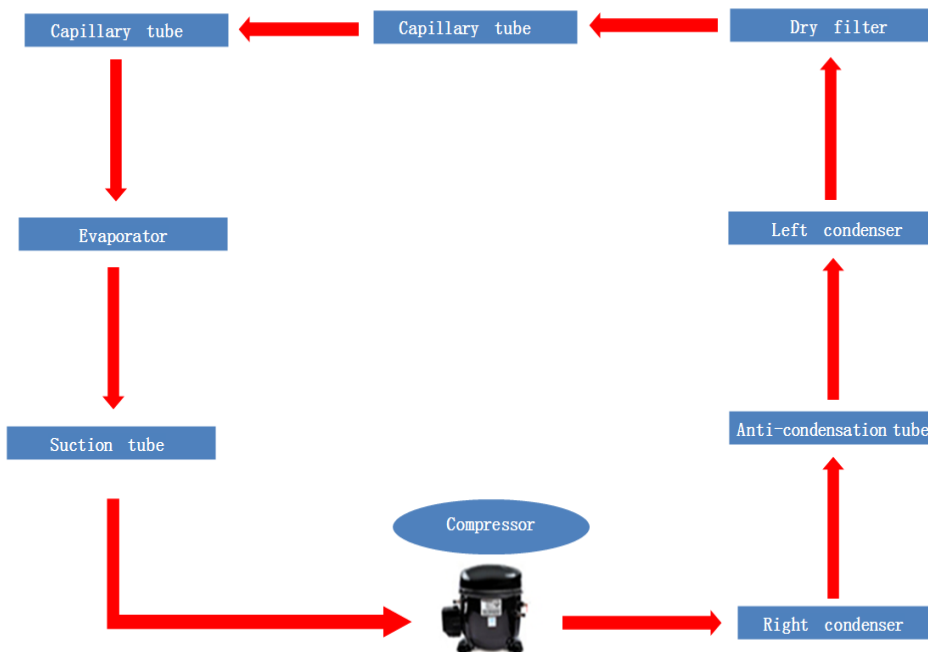

7.2 Special soldering position



8. Dismantling of parts

8.1 Parts on the door

Door seal

It's more convenient to pull out from the corner.
When reloading, the door must be installed into the tank, carefully pressed flat, and check whether there is a gap between the door seal and the box body.



Door tray

None

8.2 Parts inside the refrigerator

Rack

Lift up the rack with a proper force and pull it out towards yourself.

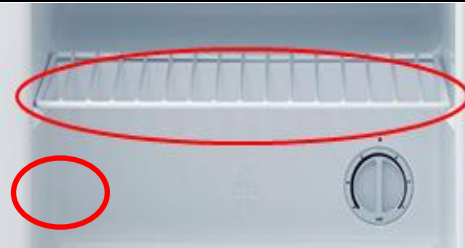

Tray

2) Lift up the tray with a proper force and pull it out towards yourself.



Freezer Drawer

None

None

8.3 Light system

Light	
Light of the refrigerating	None
Light of the freezing	None
Light switch	
	None

8.4 Evaporator and Defrost system

Evaporator in freezing chamber	
None	None

8.5 Compressor case

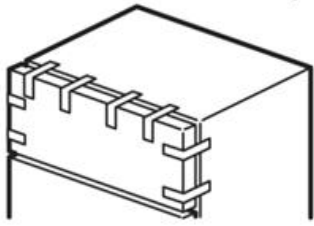
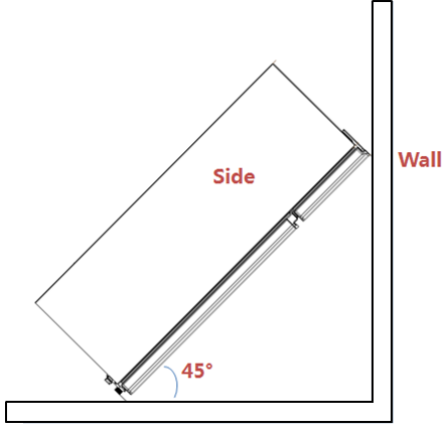
Rear cover and compressor case	
Rear cover and compressor case	None
Compressor and the cooling system pipe	
<p>1) Cut off the power, remove the goods in the refrigerator, with the tape to make the door fixed firmly and prevent the door dropping when the refrigerator dumping.</p>	
<p>2) Slowly tilt the refrigerator forward, relying on the wall or a solid enough object, leaving space to facilitate the operation. For safety, it should be carried by someone to prevent its falling.</p>	

3) Cut off the compressor pipeline.-**①**Cut off the process pipeline.-**②**Cut off the low-pressure muffler.-**③**Cut off the high-pressure exhaust pipe.

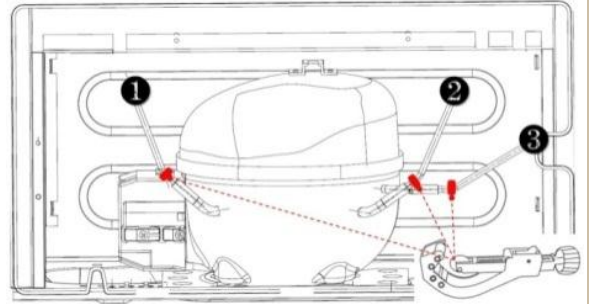

4-1) **Remove the screws(for some models)**
 -Two screws outside
 -One screw inside

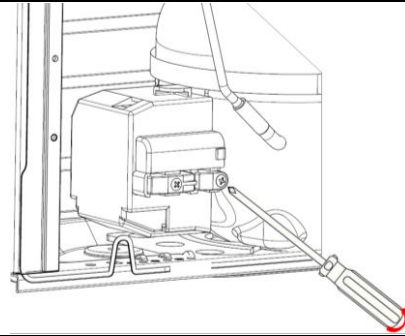

4-2) **Remove the metal clamp(for some models)**
 -Disassembly the metal clamp that is fix the electric appliance shield

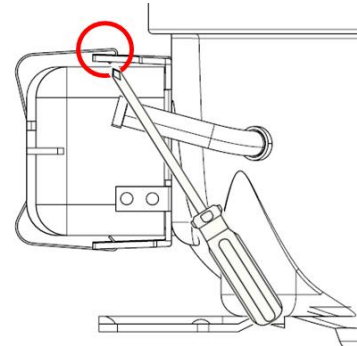

5) **Remove the clipping strip**
 Slowly pull it out

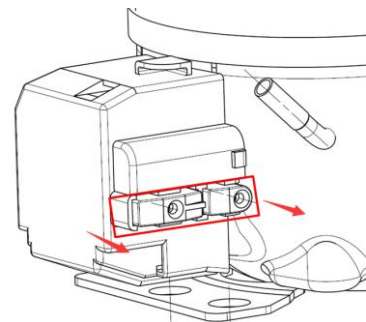

6) **Remove the protective cover**
 -Pry the protective cover slowly from the upper part,
 -Pull it out and remove it.

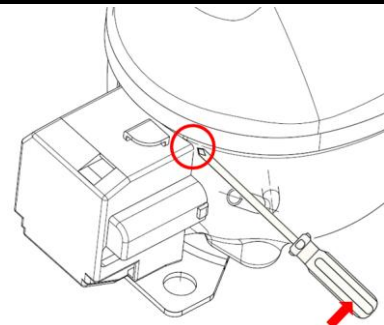

7) **Remove the starter and protector**

Unplug the starter and protector (you can use a screwdriver to pry it slowly)

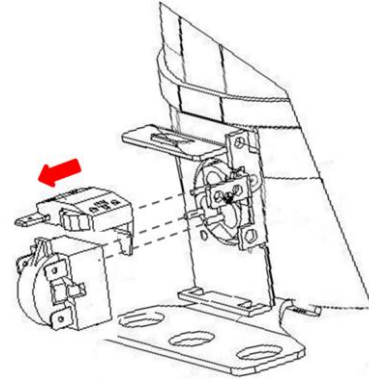

8) Loosen the screw of the compressor bottom plate, remove the floor together with the compressor from the box.

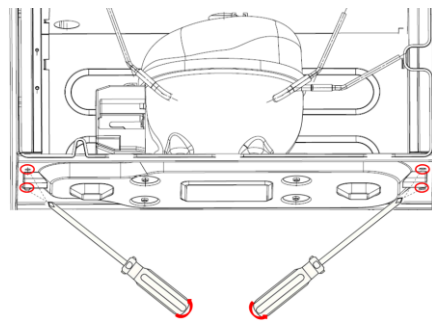

9) Use the wrench to remove the bolts by steps ④ ⑤ ⑥ ⑦, replace the compressor and reverse process can complete installation.

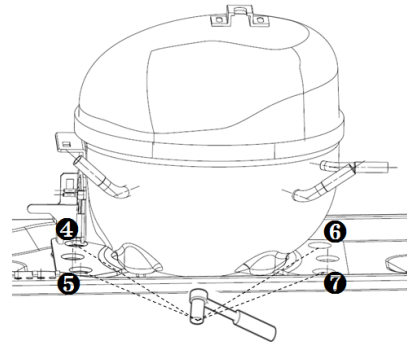

10) Use Pipe cutter cut off the condenser tube ⑧, then Shear off capillary ⑨ by the capillary tube scissors.

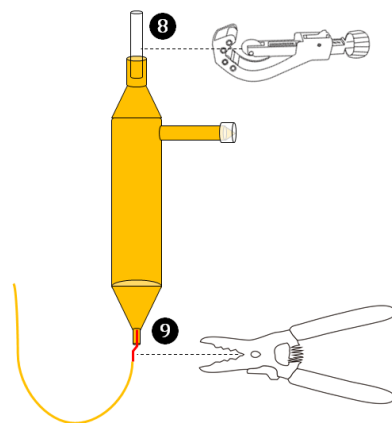

11) Replace the compressor and welding the compressor pipeline.-**10**Welding the process pipeline.-**11**Welding the low-pressure muffler.-**12**Welding the high-pressure exhaust pipe.

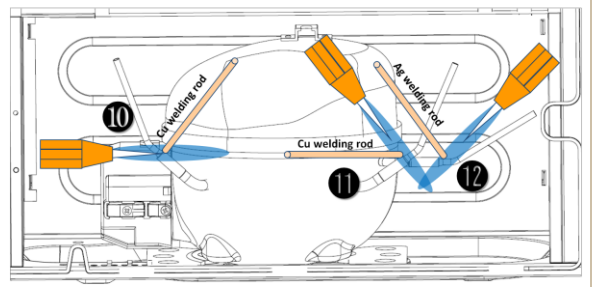

12) Replace the filter, Cu-Fe tubes welding **13** used Ag welding rod, Cu-Cu tubes welding**14** used Cu welding rod.

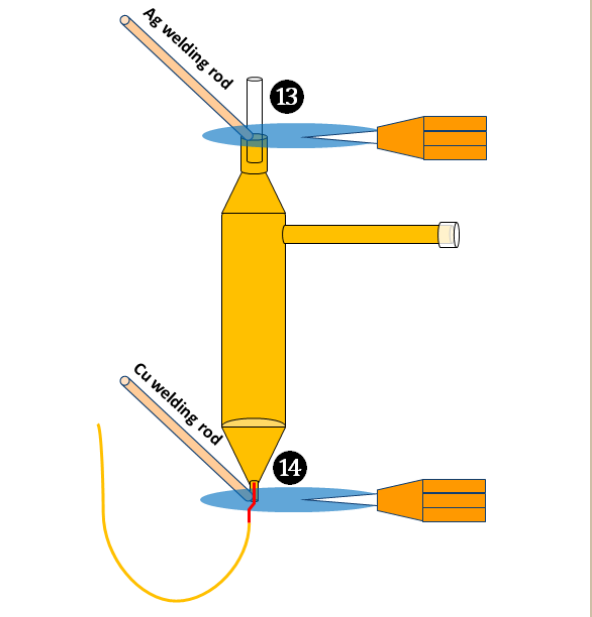

13) Vacuum system, The degree of vacuum below 6Pa.

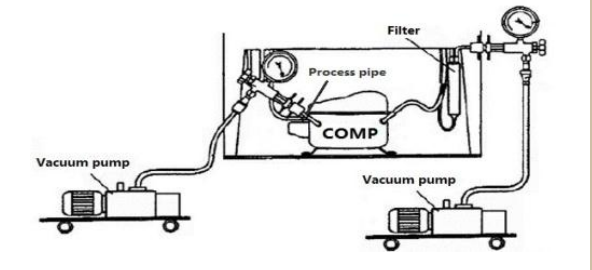

14) Perfusion refrigerant.

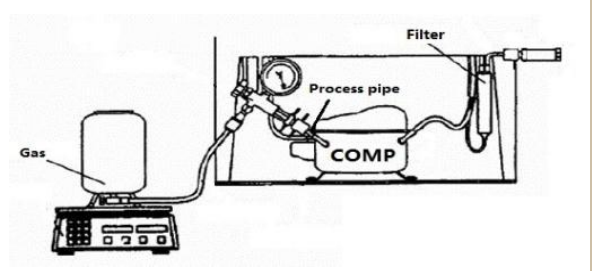

15) Use the vise grip pliers clamp the middle of the process pipe, then seal welding process tube**15** **16**.

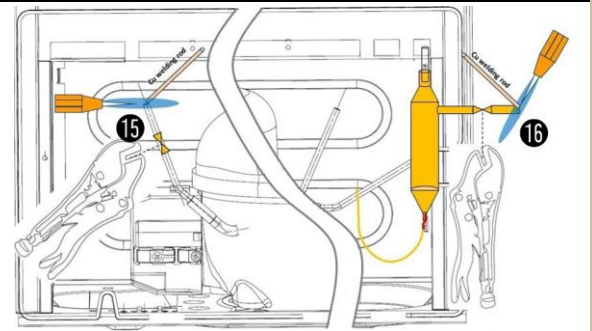

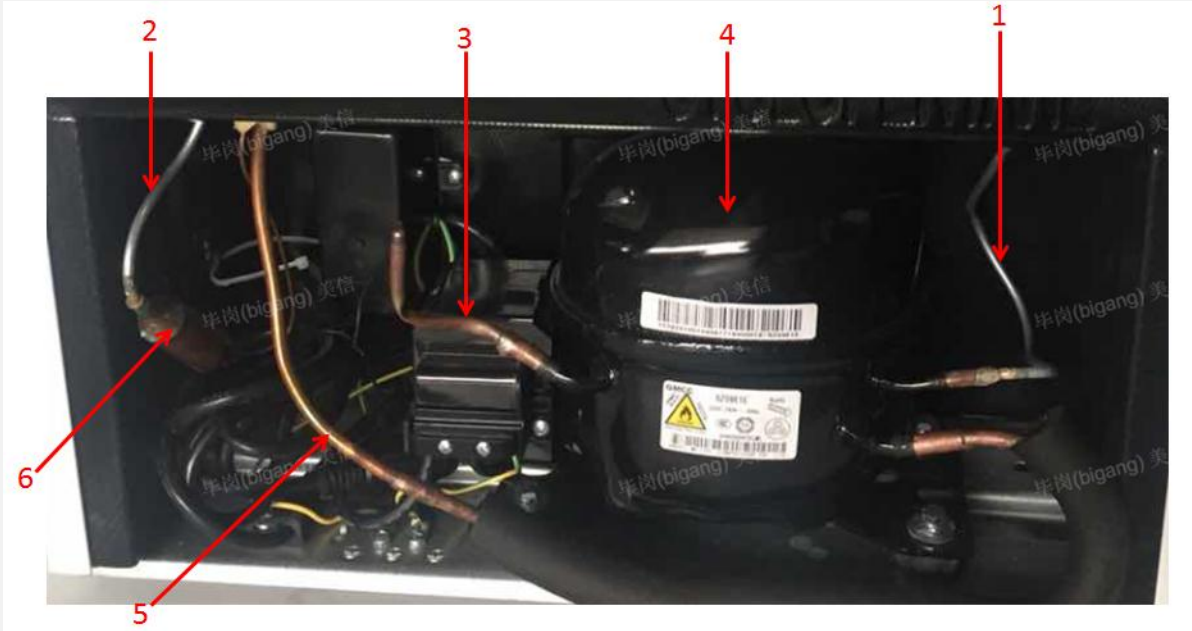
Back hanging wire tube condensor	
None	None
Piping system in the compressor case	
left condenser right condenser processing tubes	compressor suction tube dry filter
	
Drain tray	NONE

8.6 Display control board (None)

Display control board	
None	None

9. temperature sensing system

9.1 Thermostat

Thermostat

1) Remove the rotary knob, the cap and screw on the thermostat-box assembly

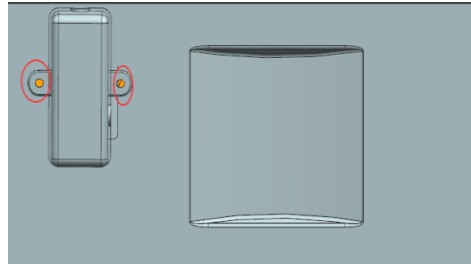

2) Remove the connector and dismantle the thermostat-box assembly

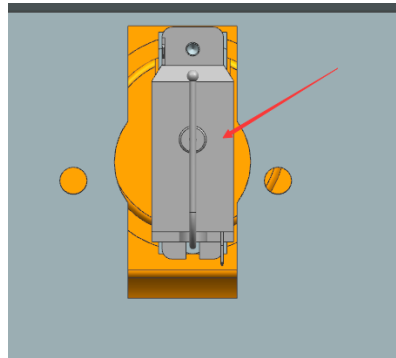

3) Loosen the thermostat fastening screw

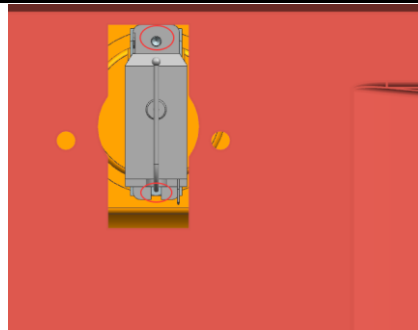

5) Remove the thermostat-box cover and replace the thermostat.

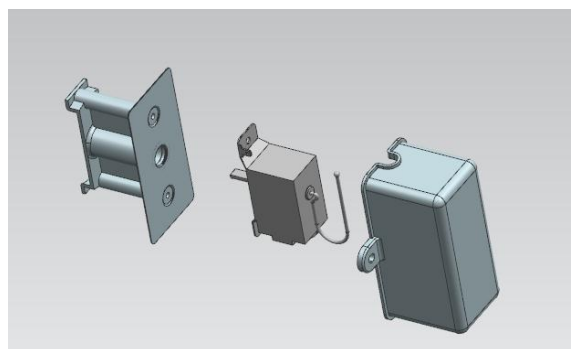

10. Function and operation

10.1 Operation panel



Direct cooling mechanical refrigerator, through the thermostat knob to adjust the stalls.

10.2 Temperature setting

Turn the temperature control knob to MAX, the internal temperature of the refrigerator becomes lower.
Turn the temperature control knob to MIN, the internal temperature of the refrigerator becomes higher.

NOTE: Please adjusting and using between "MAX" and "MIN"

10.3 Open door alarm(None)

10.4 Defrosting function

Manual defrost

11. Compressor

11.1 Compressor on and off Control specifications

1.1 When one of the following conditions is met, the compressor stops:

- 1) $T_r \leq T_{rt}$;
- 2) The compressor runs continuously for more than 3 hours (Stop 5 minutes);

1.2 When all the following conditions are met, the compressor starts up:

- 1) $T_r \geq T_{rk}$;
- 2) Compressor downtime is more than 5min.

★When 1.1 and 1.2 are not satisfied, the compressor maintains the original state

12. Troubleshooting Method

12.1 Not cooling

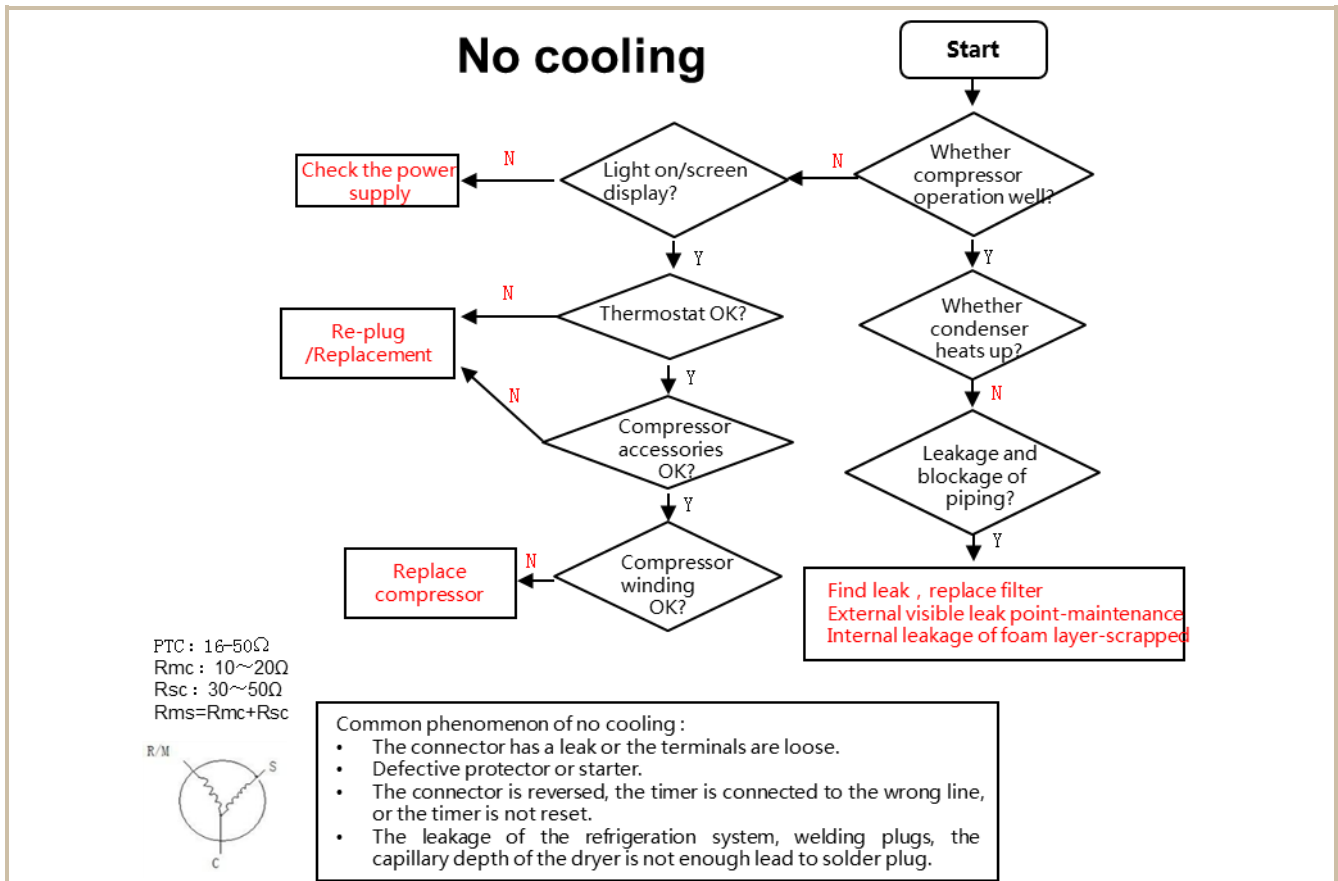

12.2 No working of compressor

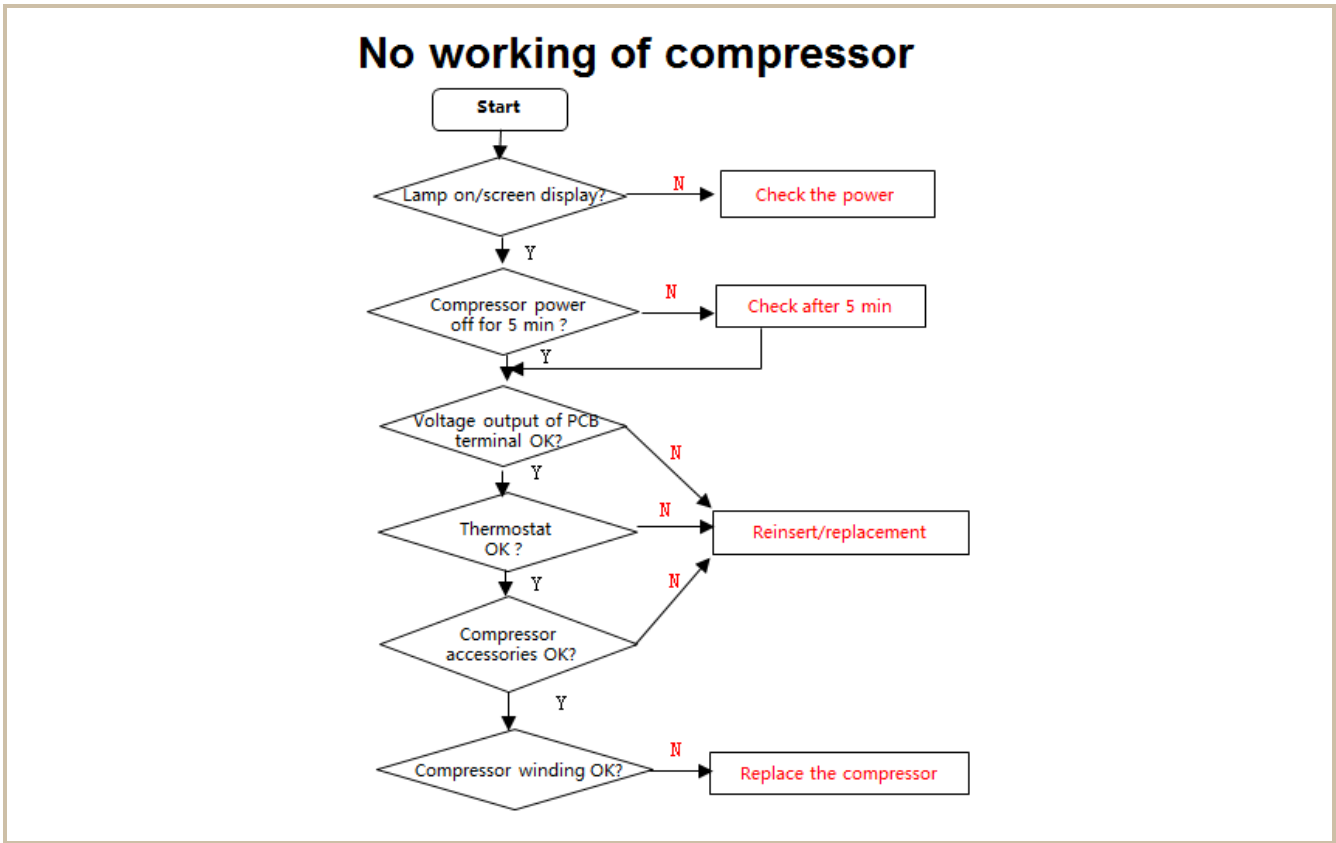

12.3 Thermostat malfunction-Undercooling

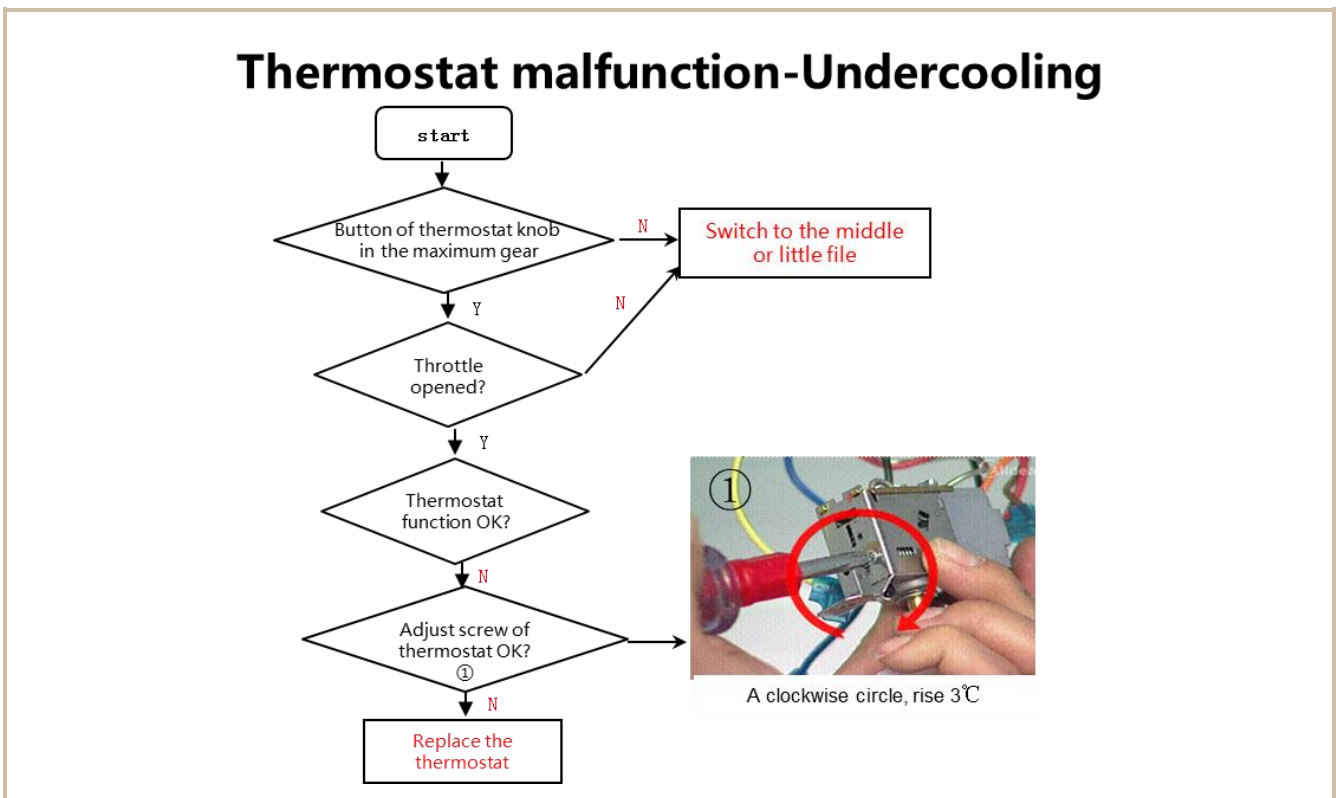

12.4 Inside frosting, no defrosting

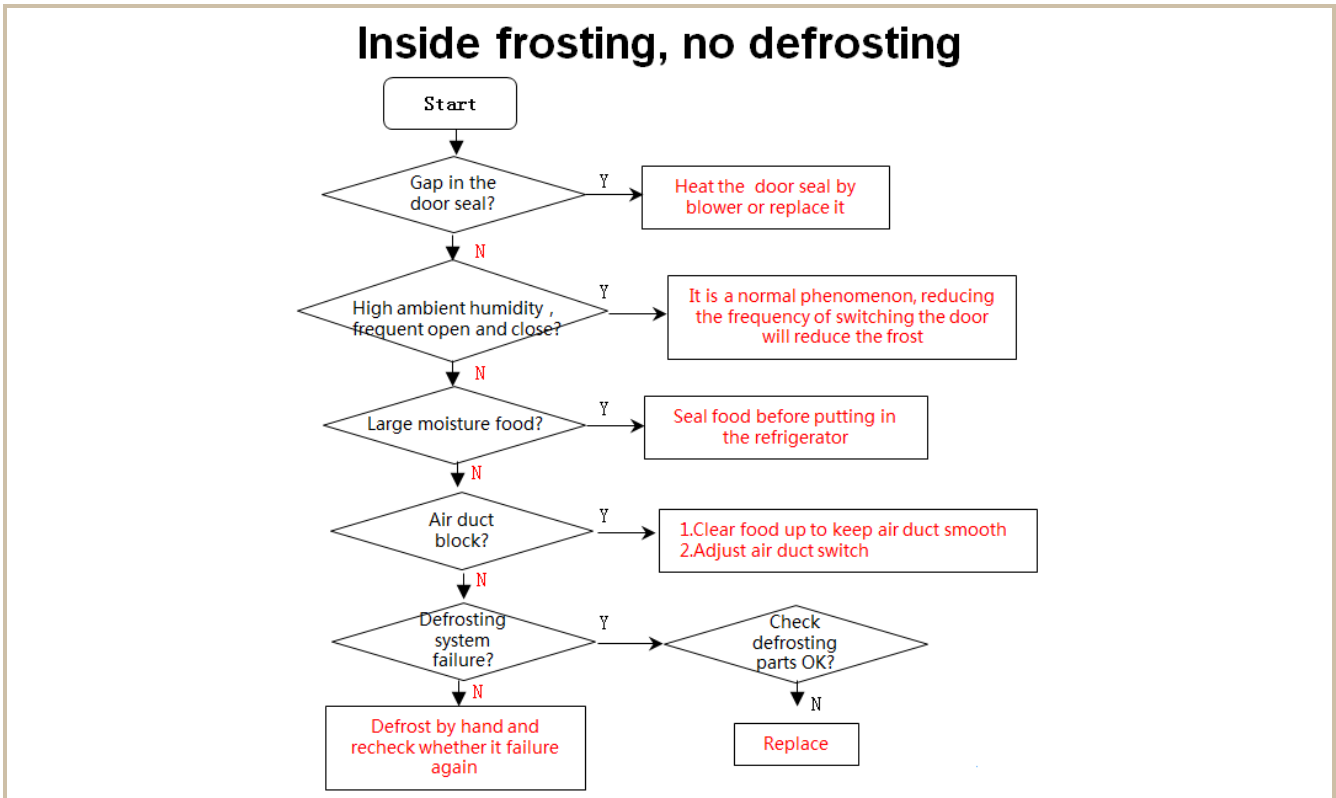

12.5 Inside frosting, no defrosting-Maintenance guidelines

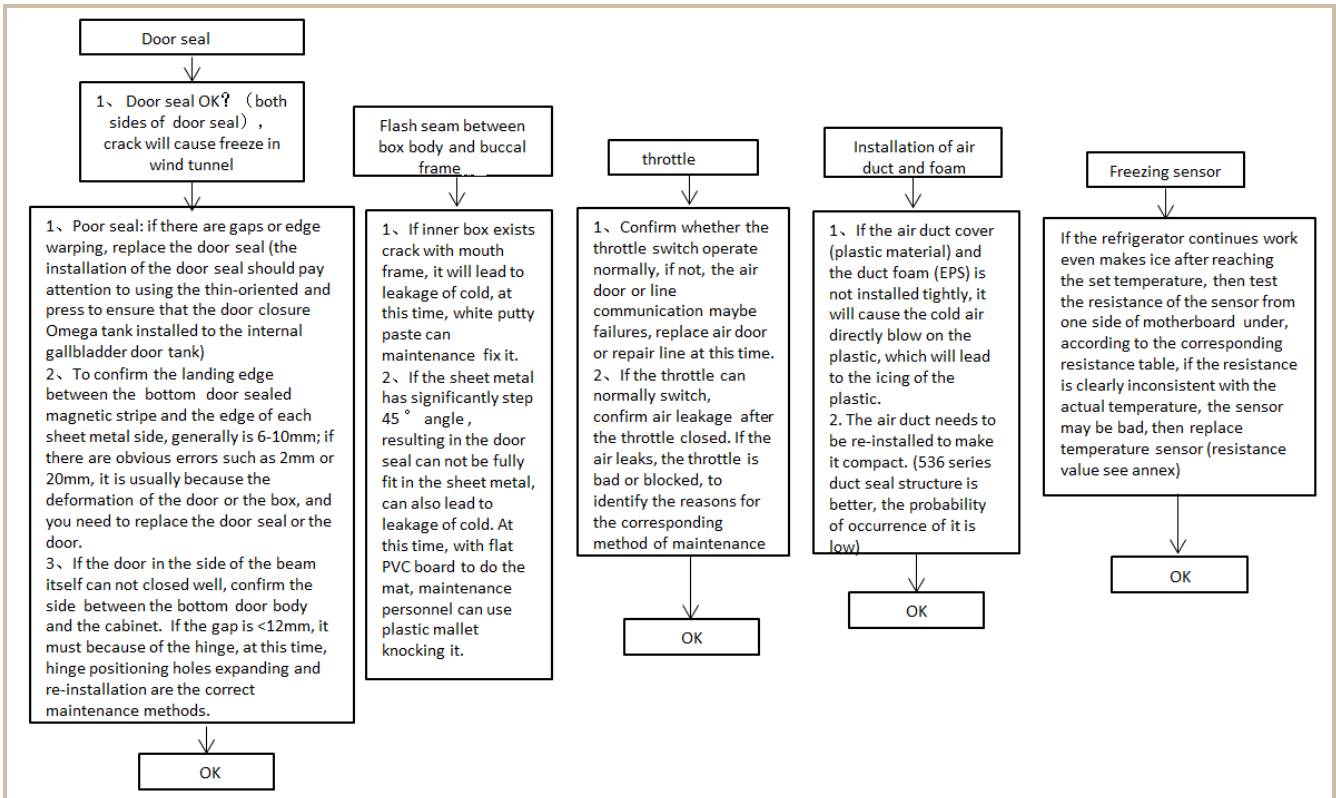

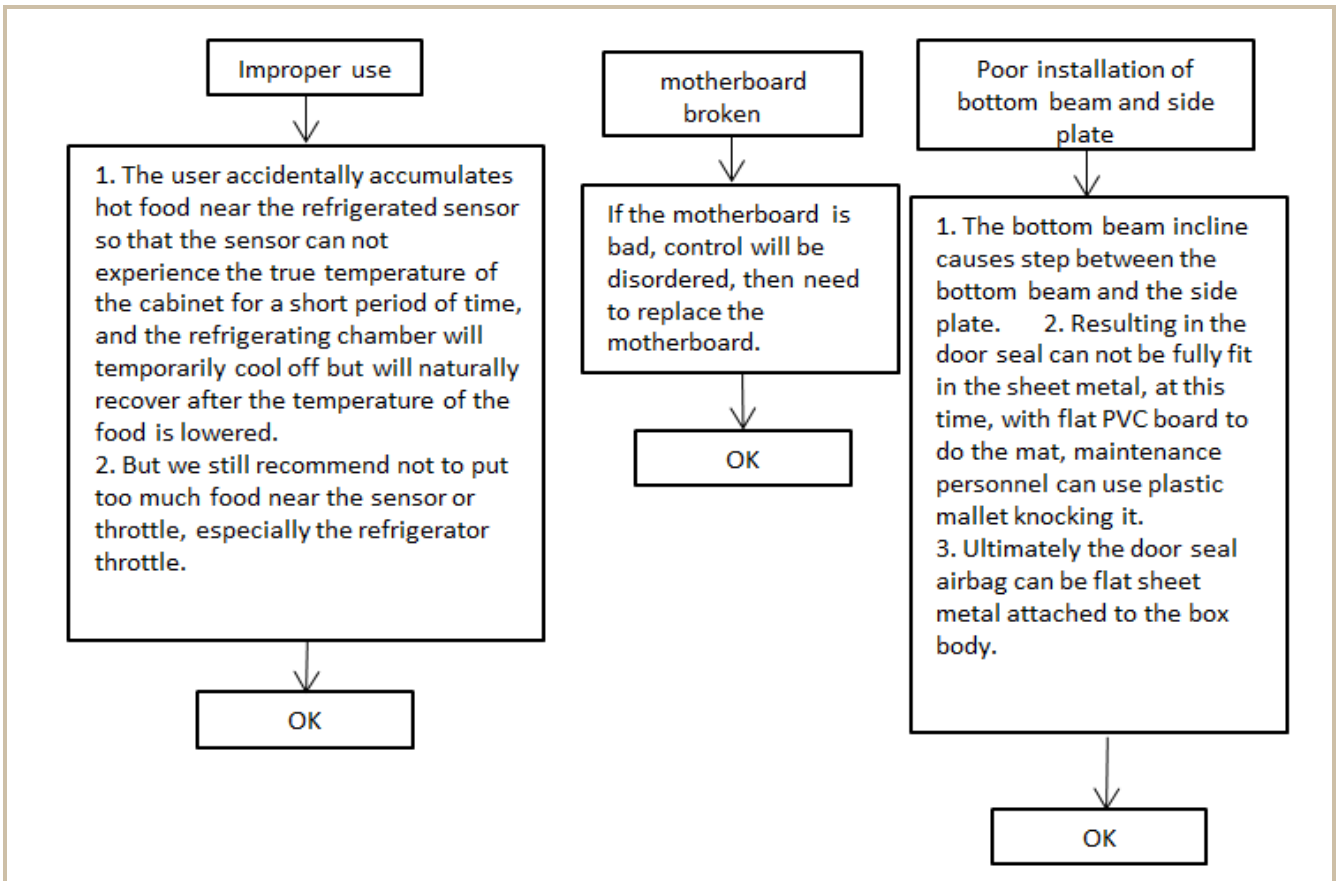

12.6 Light is not on

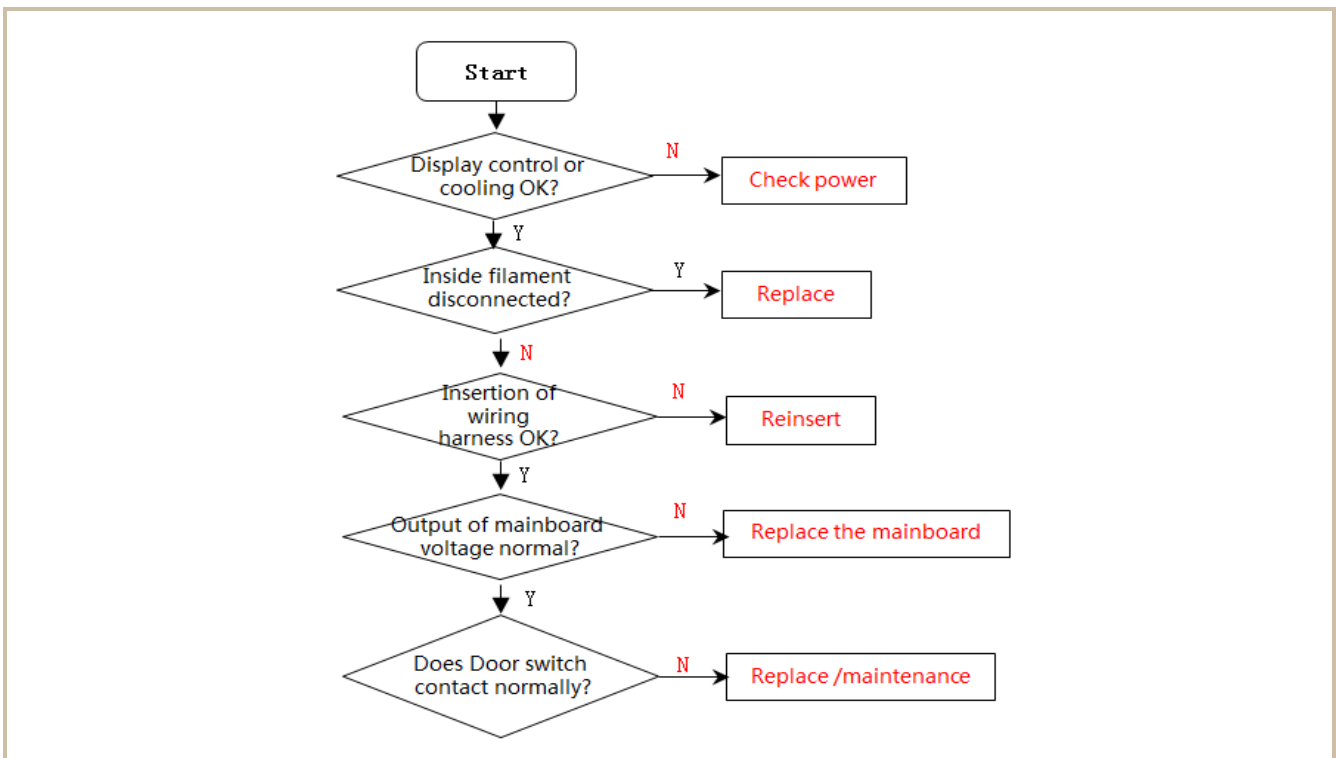

12.7 Noise

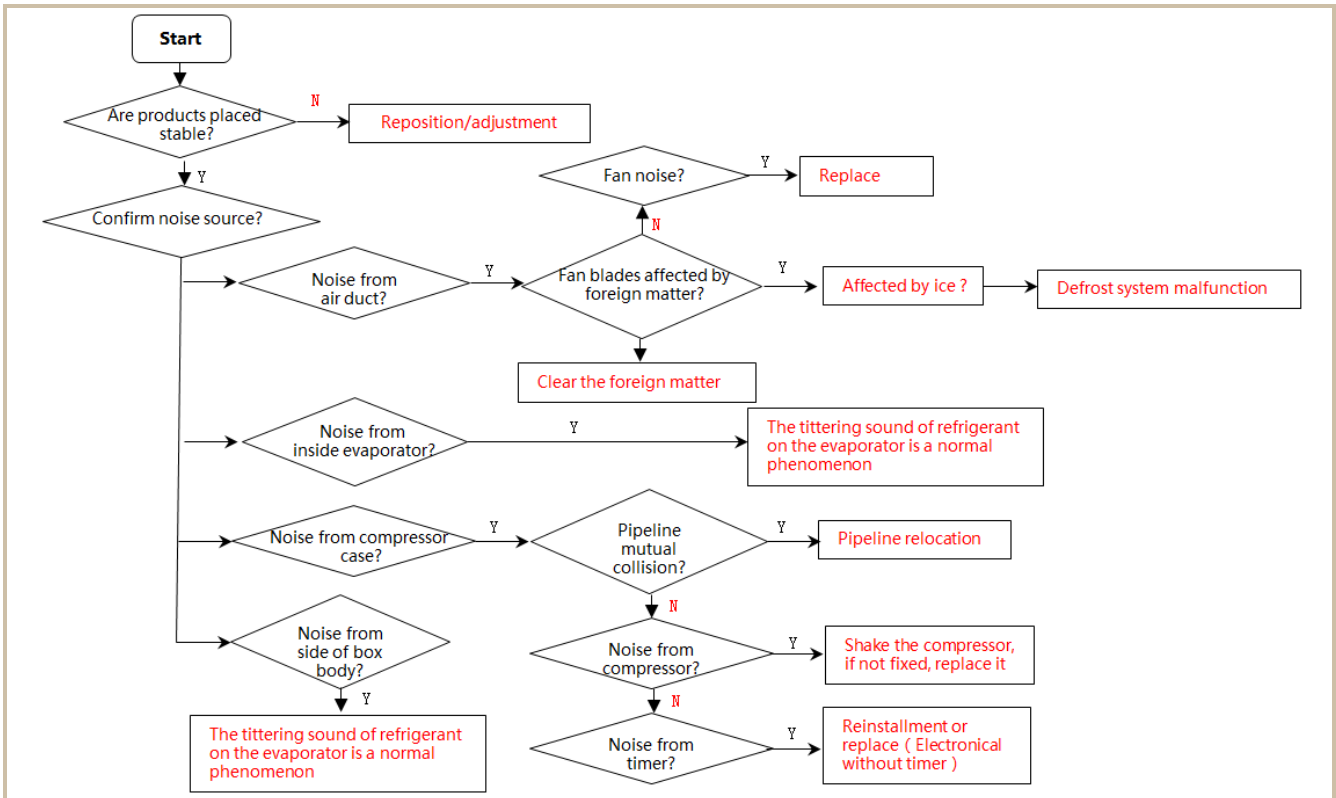

13. Figures and details of repair parts

See this section in the TSP.

Entry Guidelines (TSP System)

■ Where

Chrome

<https://tsp.midea.com>

■ How

- Midea user: Same as your [MIP](#) account & password.
- Overseas customer:

Account: Generated by TSP (provided by administrator).

Each customer have a code in Midea Group, G/E + seven numbers.

If you buy different categories from Midea group, you can see all the product information by one account.

Password: abcd1234 (please revise after login in).

If the input error more than 5 times, account will be locked, need the administrator to unlock.



Admin team:

REF: Jamie Liu(liujc5@midea.com)

IT: Martin He(dingding.he@midea.com)



**ON LINE
ANY TIME
ANY WHERE**



The symbol on the product or its packaging indicates that this product must not be disposed of with your other household waste. Instead, it is your responsibility to dispose of your waste equipment by handing it over to a designated collection point for the recycling of waste electrical and electronic equipment. The separate collection and recycling of your waste equipment at the time of disposal will help conserve natural resources and ensure that it is recycled in a manner that protects human health and the environment. For more information about where you can drop off your waste for recycling, please contact your local authority, or where you purchased your product.



MIDEA appliances after sales website

For more information about Midea appliances after sales, please visit the tsp.midea.com

For more information about the service manual, please visit the tsp.midea.com

For more information about the EV and SBOM, please visit the tsp.midea.com

Midea Refrigerators

If you need to get detailed technical information from the manufacturer, please contact:

xxx@midea.com

Refrigeration Division

Overseas Sales Company

Address: No. 176, Jinxiu Avenue, Economic-Technological Development Area, Hefei, Anhui, China