

Service Manual

Applicable models	Model Code
UR-BCD87CM-ST	22031020000086
UR-BCD87CM-ST	22031020000621
UL-BCD87CM-ST	22031020000093
UR-BCD87CM-ST	22031010000462
UR-BCD87CM-ST	92031020Z00021
UR-BCD87CM-ST	92031020Z00022
UR-BCD87CM-ST	92031020Z00023
UR-BCD87CM-ST	92031020Z00024

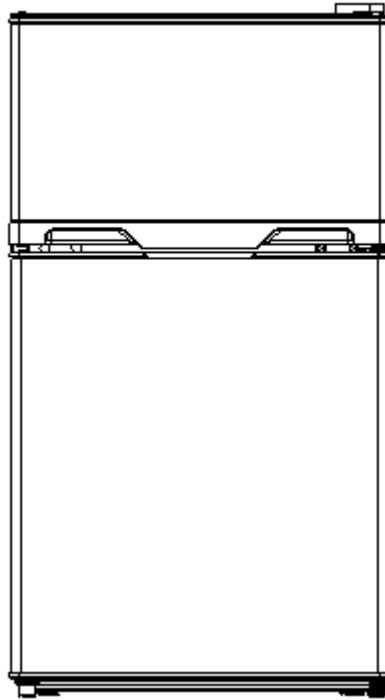

(The picture is only for reference, and specific appearance and configuration are subject to the real product)

Prepared by	R&D:Luo Xinjun
Reviewed by	QA:WangTao SVC:ChenLei
Approved by	R&D:Tang Tao SVC:GuangTaoshuai



Warning

Important Safety Notice

The Maintenance Manual is only for the use of maintenance personnel with certain experience and background in electrical, electronic and mechanical field.

Any attempt to repair main devices may lead to personal injury and property loss.

Manufacturers or distributors are not responsible for the content of the Manual and interpretation thereof.

Midea Refrigerators

Technical Maintenance Manual

Copyright @2016

All rights reserved. Replication of all or part of the Manual in any forms shall not be allowed without written approval by the Overseas Sales Corporation of Midea Refrigerators.

Contents

1.SAFETY WARNING CODE	5
1.1 WARNING FOR OPERATION SAFETY	5
1.2 SAFETY INSTRUCTION FOR REFRIGERANT	8
2.DESCRPTION FOR PRODUCT FEATURES	9
3.INSTALLATION AND COMMISSIONING	10
3.1 HANDLING	10
3.2 DISASSEMBLY (NONE).....	10
3.3 INSTALLATION LOCATION	10
3.4 LEVELING OF THE REFRIGERATOR.....	10
3.5 CHANGE THE DOOR OPENING DIRECTION.....	10
3.6 INSTALLATION OF HANDLE (NONE)	12
3.7 INSTALLATION OF DOOR LOCK(NONE)	12
3.8 ADJUSTMENT TO LEVEL THE DOOR(NONE)	12
3.9 ADJUSTMENT TO SHELVES(NONE)	12
4.TERMS	13
4.1 DEFINITION OF MODEL(NONE)	13
4.2 LOCATION OF NAMEPLATE.....	13
5.PRODUCT SPECIFICATION	14
5.1 TYPE SPECIFICATION(NONE)	14
5.2 ELECTRICAL PARAMETERS.....	14
5.3 REFRIGERATING TEMPERATURE.....	14
5.4 DEFROSTING PARTS	15
5.5 CIRCUIT DIAGRAM.....	15
6.INTERNAL VIEW AND DIMENSION	16
6.1 MAIN PARTS AND THEIR NAMES.....	16
6.2 EXTERNAL DIMENSION	17
7.REFRIGERATING PIPING SYSTEM AND CIRCULATING ROUTE OF COOLING AIR ..	18
7.1 REFRIGERATING PIPING SYSTEM	18
7.2 CIRCULATING ROUTE OF COOLING AIR(NONE).....	18
8. DISMANTLING OF PARTS	19
8.1 PARTS ON THE DOOR	19
8.2 PARTS INSIDE THE REFRIGERATOR.....	19
8.3 LIGHT SYSTEM(NONE).....	20
8.4 AIR DUCT COMPONENTS REFRIGERATING CHAMBER.....	20
8.5 AIR DUCT COMPONENTS IN FREEZING CHAMBER AND FAN MOTOR.....	20

8.6EVAPORATOR AND TEMPERATURE SENSING SYSTEM	20
8.6COMPRESSOR CASE	21
8.7DISPLAY AND MAIN CONTROL PANEL(NONE)	21
8.8 BAR COUNTER(NONE)	22
8.9 WATER DISPENSER(NONE)	22
8.10 ICE MAKER(NONE)	22
9. FUNCTION AND OPERATION	23
9.1OPERATION PANEL.....	23
9.2TEMPERATURE CONTROL.....	23
9.3GIVE AN ALARM(NONE)	23
9.4FAILURE CODE AND SOLUTIONS(NONE).....	23
9.5DEFROST FUNCTION	23
9.6COMPRESSOR FAN CONTROL(NONE)	23
9.7TEST MODE (NONE).....	23
9.8SELF-DIAGNOSIS (NONE).....	23
10.CIRCUIT DESCRIPTION	24
10.1 POWER SUPPLY(NONE).....	24
10.2 TEST CIRCUIT FOR DOOR SWITCH(NONE).....	24
10.3 TEMPERATURE TEST CIRCUIT(NONE)	24
10.4FREEZER CHAMBER FAN MOTOR CIRCUIT (NONE).....	24
10.5REFRIGERATING CHAMBER FAN MOTOR CIRCUIT (NONE)	24
10.6CONDENSATION FAN CIRCUIT (NONE)	24
10.5 FAN MOTOR CIRCUIT OF THE VENTILATION DOOR(NONE)	24
10.6RESISTANCE VALUE OF THE SENSOR (R/T) (NONE).....	24
11.TROUBLESHOOTING METHOD.....	25
11.1 NOT COOLING	25
11.2 NOT WORKING OF COMPRESSOR	26
11.3 -THERMOSTAT MALFUNCTION-UNDERCOOLING.....	27
11.4 NOISE	27
12. FIGURES AND DETAILS OF REPAIR	
PARTS(DOCUMENTSAREPROVIDEDSEPARATELY)	28
12.1FIGURES	28
12.2LIST OF PARTS AND COMPONENTS.....	28
13APPENDIX:.....	29
13.1ELECTRICAL SCHEMATIC DIAGRAM(NONE)	29
13.2REFRIGERATOR MAINTENANCE TOOLING AND EQUIPMENT AND MATERIAL	29

1.Safety Warning Code

1.1Warning for operation safety

Important Safety Instructions

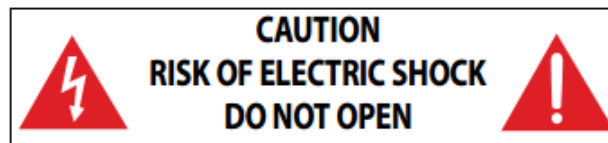

This symbol indicates that dangerous voltage constituting a risk of electric shock is present within your freezer.



This symbol indicates that there are important operating and maintenance instructions in the literature accompanying your freezer.

WARNING

- 1 Read these instructions.
- 2 Keep these instructions.
- 3 Heed all warnings.
- 4 Follow all instructions.
- 5 Do not use this appliance near water.
- 6 Clean only with a damp cloth.
- 7 Do not block any ventilation openings.
- 8 Install in accordance with the manufacturer's instructions.
- 9 Do not install near any heat sources, such as radiators, heat registers, stoves, or other apparatus that produce heat.
- 10 Do not defeat the safety purpose of the polarized or grounding-type plug. A polarized plug has two blades with one wider than the other. A grounding type plug has two blades and a third grounding prong. The wide blade or the third prong are provided for your safety. If the provided plug does not fit into your outlet, consult an electrician for replacement of the obsolete outlet.
- 11 Protect the power cord from being walked on or pinched, particularly at plugs, convenience receptacles, and the point where they exit from the appliance.
- 12 Do not attempt to modify or extend the power cord of this appliance.
- 13 Unplug this appliance during lightning storms or when it will not be used for long periods of time.
- 14 Make sure that the available AC power matches the voltage requirements of this appliance.

- 15 Do not handle the plug with wet hands. This could result in an electric shock.
- 16 Unplug the power cord by holding the plug, never by pulling the cord.
- 17 Do not turn the appliance on or off by plugging or unplugging the power cord.
- 18 Refer all servicing to qualified service personnel. Servicing is required when the appliance has been damaged in any way, such as the power-supply cord or plug is damaged, liquid has been spilled or objects have fallen into the appliance, the appliance has been exposed to rain or moisture, does not operate normally, or has been dropped.
- 19 To reduce the risk of fire or electric shock, do not expose this appliance to rain, moisture, dripping, or splashing, and no objects filled with liquids should be placed on top of it.
- 20 Do not use extension cords or ungrounded (two prong) adapters.
- 21 This appliance is not intended for use by persons (including children) with reduced physical, sensory or mental capabilities, or lack of experience and knowledge, unless they have been given supervision or instruction concerning use of the appliance by a person responsible for their safety.
- 22 Children should be supervised to ensure that they do not play with the appliance.
- 23 If the supply cord is damaged, it must be replaced by the manufacturer, its service agent, or similarly qualified person, in order to avoid a hazard.
- 24 Take off the doors and leave the shelves in place so that children may not easily climb inside.



WARNING

Electric Shock Hazard

Failure to follow these instructions can result in electric shock, fire, or death.

- 1 **WARNING**–Keep ventilation openings, in both the freezer and the built-in structure, clear of obstruction.
- 2 **WARNING**–Do not touch the interior of the freezer with wet hands. This could result in frost bite.
- 3 **WARNING**–Do not use mechanical devices or other means to accelerate the defrosting process, other than those recommended by the manufacturer.
- 4 **WARNING**–Do not damage the refrigerant circuit.

- 5 **WARNING**—Do not damage the refrigerant tubing when handling, moving, or using the freezer.
- 6 **WARNING–DANGER**—Never allow children to play with, operate, or crawl inside the freezer.
Risk of child entrapment. Before you throw away your old freezer:
 - 1) Take off the doors
 - 2) Leave the shelves in place so that children may not easily climb inside
- 7 Unplug the freezer before carrying out user maintenance on it.
- 8 This freezer can be used by children age eight years and older and persons with reduced physical or mental capabilities or lack of experience and knowledge if they are given supervision or instruction concerning the use of the freezer in a safe way and understand the hazards involved. Children should not play with the freezer. Cleaning and maintenance should not be performed by children without supervision.
- 5 **WARNING**—Do not damage the refrigerant tubing when handling, moving, or using the freezer.
- 6 **WARNING–DANGER**—Never allow children to play with, operate, or crawl inside the freezer.
Risk of child entrapment. Before you throw away your old freezer:
 - 1) Take off the doors
 - 2) Leave the shelves in place so that children may not easily climb inside
- 7 Unplug the freezer before carrying out user maintenance on it.
- 8 This freezer can be used by children age eight years and older and persons with reduced physical or mental capabilities or lack of experience and knowledge if they are given supervision or instruction concerning the use of the freezer in a safe way and understand the hazards involved. Children should not play with the freezer. Cleaning and maintenance should not be performed by children without supervision.
- 9 If a component part is damaged, it must be replaced by the manufacturer, its service agent, or similar qualified persons in order to avoid a hazard.
- 10 Please dispose of the freezer according to local regulations as the freezer contains flammable gas and refrigerant.
- 11 Follow local regulations regarding disposal of the freezer due to flammable refrigerant and gas. All refrigeration products contain refrigerants, which under the guidelines of federal law must be removed before disposal. It is the consumer's responsibility to comply with federal and local regulations when disposing of this product.

- 12** This freezer is intended to be used in household and similar environments.
- 13** Do not store or use gasoline or any flammable liquids inside or in the vicinity of this freezer.
- 14** Do not use extension cords or ungrounded (two-prong) adapters with this freezer. If the power cord is too short, have a qualified electrician install an outlet near the freezer. Use of an extension cord can negatively affect the freezer's performance.

Grounding requirement

This freezer must be grounded. This freezer is equipped with a cord having a grounding wire with a grounding plug. The plug must be inserted into an outlet that is properly installed and grounded.

Improper use of the grounding plug can result in a risk of electric shock. Consult a qualified electrician or service person if the grounding instructions are not completely understood, or if doubt exists as to whether the freezer is properly grounded.

1.2 Safety instruction for refrigerant

⚠ WARNING  **Explosion Hazard.**

Keep flammable materials and vapors, such as gasoline, away from freezer. Failure to do so can result in fire, explosion, or death.

DANGER—Risk of Fire or Explosion. Flammable Refrigerant Used. To Be Repaired Only By Trained Service Personnel. Do Not Use Mechanical Devices. Do Not Puncture Refrigerant Tubing.
 CAUTION—Risk of Fire or Explosion. Flammable Refrigerant Used. Consult Repair Manual/Owner's Guide Before Attempting To Service This Product. All Safety Precautions Must be Followed.
 CAUTION—Risk of Fire or Explosion. Dispose of Properly In Accordance With Federal Or Local Regulations. Flammable Refrigerant Used.
 CAUTION—Risk of Fire or Explosion Due To Puncture Of Refrigerant Tubing; Follow Handling Instructions Carefully. Flammable Refrigerant Used.



2. Description for product features

This product is provided with following features:

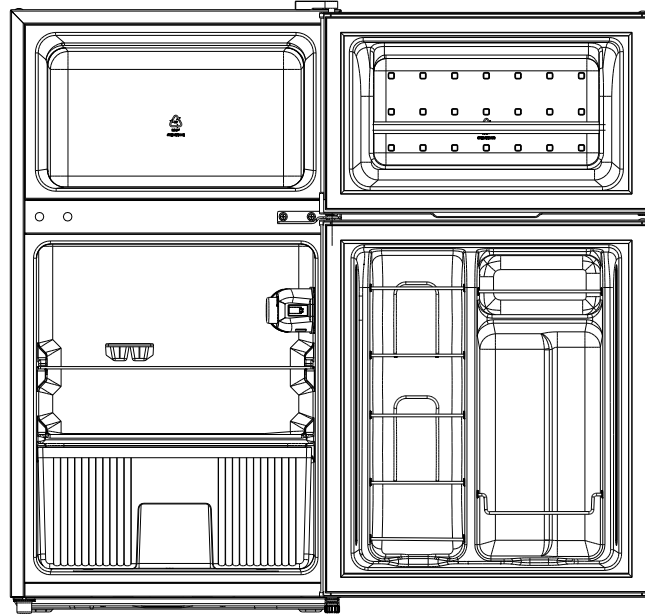

(The picture is only for reference, and specific appearance and configuration are subject to the real product)

- 1) Mechanical temperature control
- 2) Manual defrost
- 3) Change the door opening direction

3.Installation and commissioning

3.1 Handling

<ol style="list-style-type: none"> 1) Protect the refrigerator in moving it. Same as shown in left photo, please move it by hand cart with cushion. 2) Remove all packing materials and bottom cushion, then move it into house for placement. 3) After moving it to appropriate location, wait for 2 hours before power on. 	
---	--

3.2 Disassembly (None)

3.3 Installation location

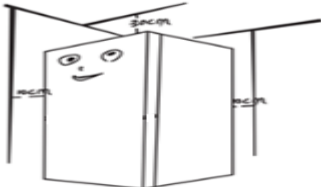
<p>Location that is easy for ventilation shall be chosen to facilitate heat dissipation, enhance its performance and reduce the energy consumption.</p>	
---	--

3.4 Leveling of the refrigerator

<p>If the refrigerator cannot be placed steadily, adjust the footing to level it.</p>	
---	--

3.5 Change the door opening direction

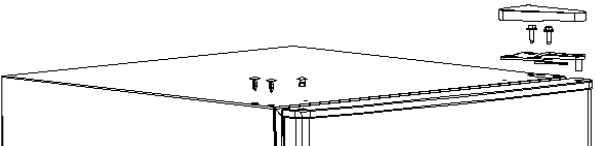
<ol style="list-style-type: none"> 1) Remove the hinge cover. Unscrew screws. Remove the upper hinge, Insert pins and hole cover. 	
--	--

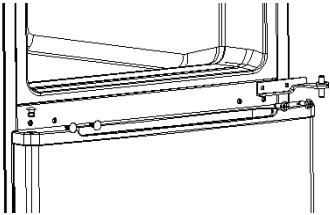
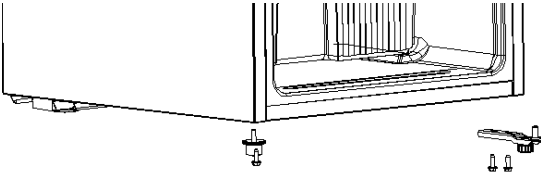
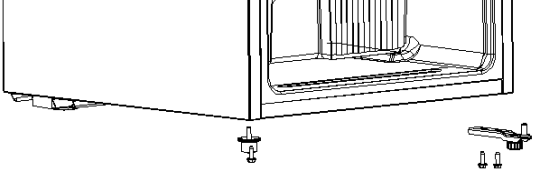
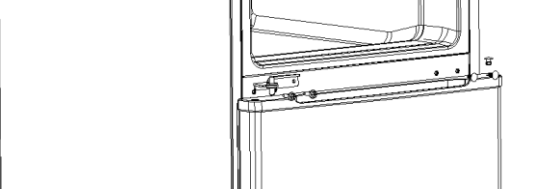
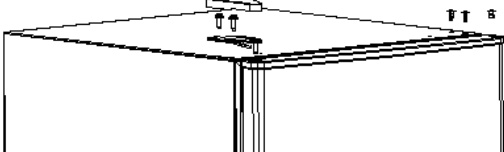
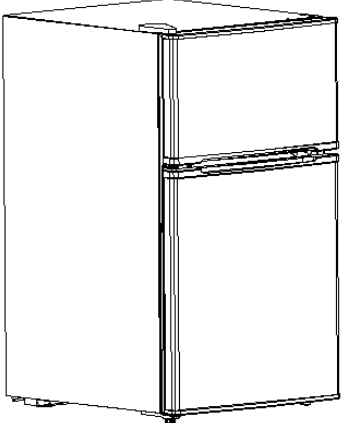
<p>2) Remove the up door. Unscrew screws. Remove the middle hinge, Insert pins and hole cover.</p>	
<p>3) Remove the bottom door. Unscrew screws and levelling feet. Remove the lower hinge adjust feet assembly.</p>	
<p>4) Fix the levelling feet, lower hinge adjust feet assembly and screws in the opposite side.</p>	
<p>5) Place the bottom door. Place and fix the the middle hinge. Fix the Insert pins and hole cover.</p>	
<p>6) Place the up door. Place and fix the the upper hinge. Fix the hinge cover, Insert pins and hole cover.</p>	
<p>7) Finish.</p>	

3.6 Installation of handle (None)

3.7 Installation of door lock(None)

3.8 Adjustment to level the door(None)

3.9 Adjustment to shelves(None)

4.Terms

4.1 Definition of model(None)

4.2 Location of nameplate

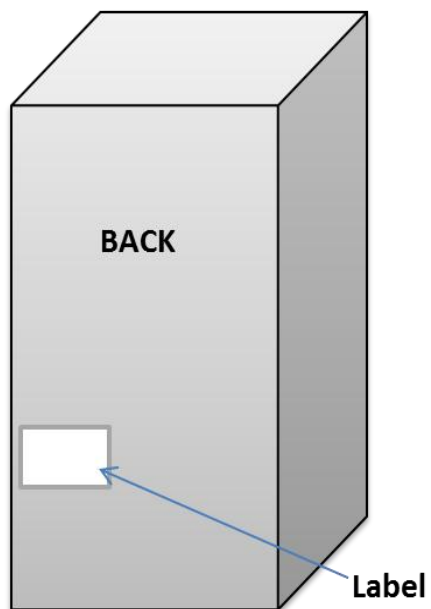

(The picture is only for reference, and specific appearance and configuration are subject to the real product)

5. Product specification

5.1 Typespecification(None)

5.2 Electrical parameters

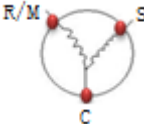
Product Name			UR-BCD87CM-S T	UR-BCD87C M-ST	UL-BCD87C M-ST	UR-BCD87C M-ST
Product Code			22031020000086 92031020Z00021 92031020Z00022 92031020Z00023 92031020Z00024	22031020000 621	22031020000 093	22031010000 462
Name	Item	Type	Specification	Specification	Specification	Specification
Compressor	Compressor	/	FZ40C1J	EZ40E1D-U	DK25BZ1	FZ40E1J
	Starter	PTC	QP2-4R7	QPE2-A4R7 MD3	QP2-4.7C/QP 2-4R7C	8EA14C1-02
	Overload protector	OLP	DRB20T61A1	DRB22T61A 1	B54-105/DR B-B54-105	4TM158NFB YY
	Winding resistance of compressor wiring terminal		Rmc:2.5-14.5Ω Rsc:7.4-21.4Ω Rms=Rmc+Rsc	Rmc:13.50±7% Ω Rsc:10.64±7%Ω Rms=Rmc+Rsc	Rmc:14.6±7%Ω Rsc:6.9±7%Ω Rms=Rmc+Rsc	Rmc:14.4±7%Ω Rsc:9.5±7%Ω Rms=Rmc+Rsc
Motor	Fan motor of the freezing chamber	/	/	/	/	/
	Ventilation door of the refrigerating chamber	/	/	/	/	/
	Condensation fan	/	/	/	/	/
Lights inside the refrigerator	Lights inside the freezing chamber	/	/	/	/	/
	Lights inside the refrigerating chamber	/	115V/15W	115V/15W	115V/15W	115V/15W
	Switch of the refrigerator door	/	Sector	Sector	Sector	Sector

5.3Refrigerating temperature

 Temperature tolerance $\leq 2^{\circ}\text{C}$

Compartment	The highest ($^{\circ}\text{C}$)	Lowest ($^{\circ}\text{C}$)
Freezing	-12	-24
Refrigerating	10	0

Variable temperature	/	/
----------------------	---	---

5.4 Defrosting parts

Defrosting period	Initial defrosting period	Normal defrosting period
	/	/
Defrosting sensor	/	/
Defrosting temperature controller	/	/
Thermal fuse	/	/
Defrosting heater in freezing chamber	/	/

5.5 Circuit diagram

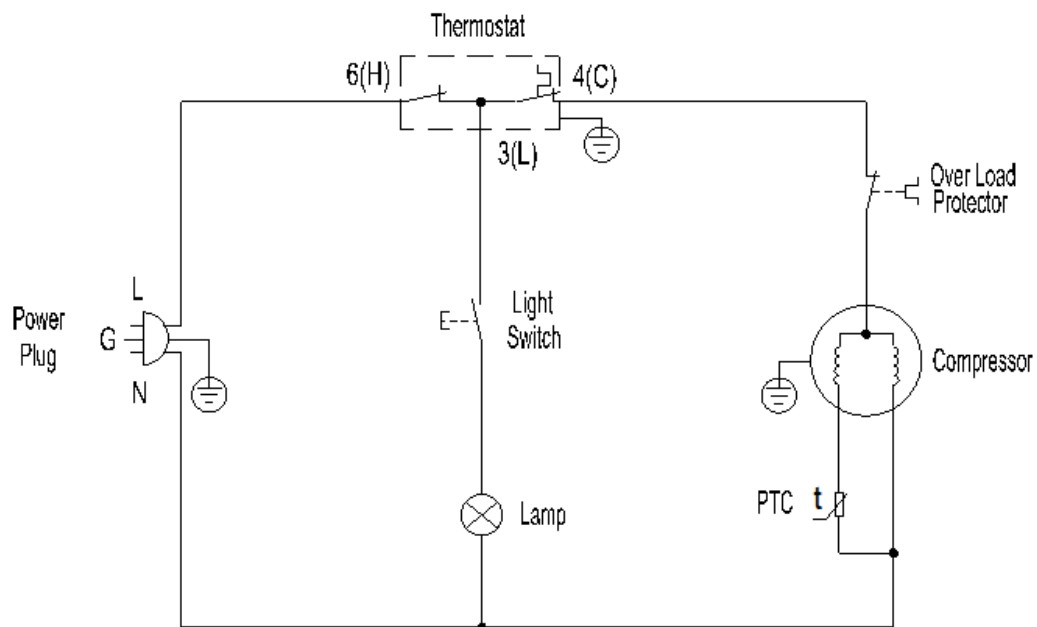

6. Internal view and dimension

6.1 Main parts and their names

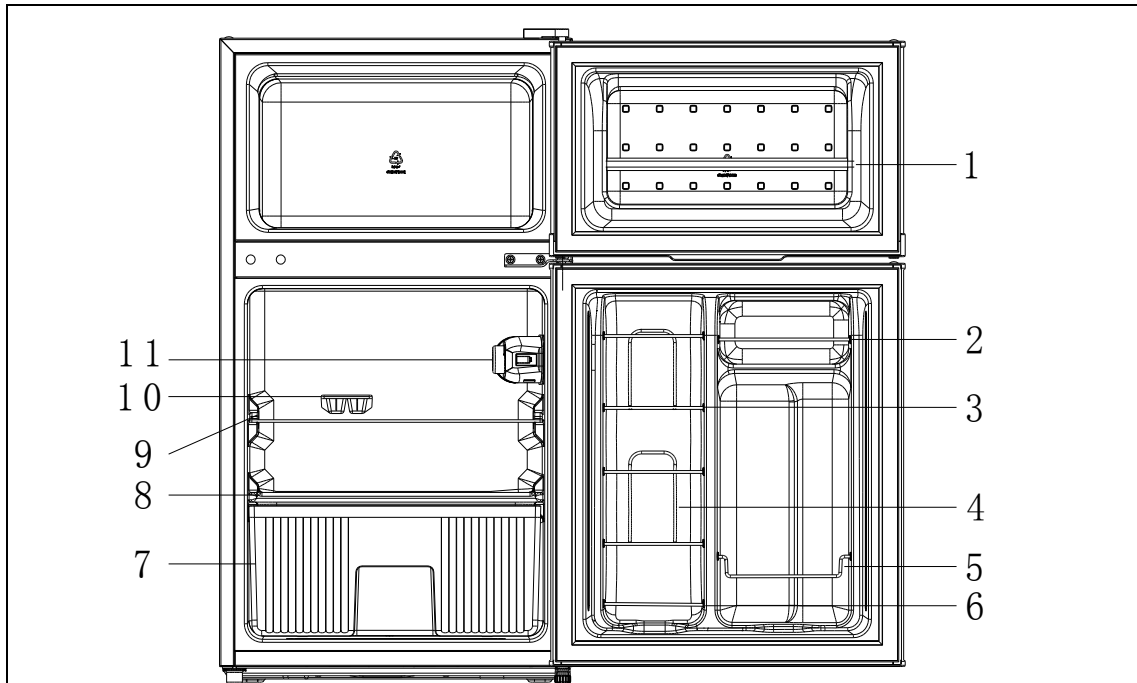

(The picture is only for reference, and specific appearance and configuration are subject to the real product)

Freezer chamber	Refrigerator chamber
1. Toolbar	2. Steel column strip 3. Zip-top can steel bar 4. Zip-top can steel bar 5. Steel column strip 6. Steel column strip 7. Fruits and vegetables box 8. Glass shelf assembly 9. Glass shelf assembly 10. Ice box 11. Temperature-control box assembly

6.2 External dimension

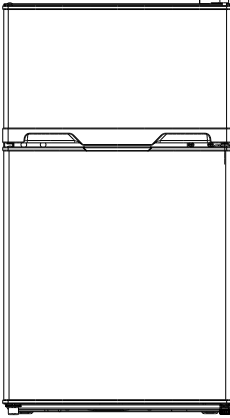
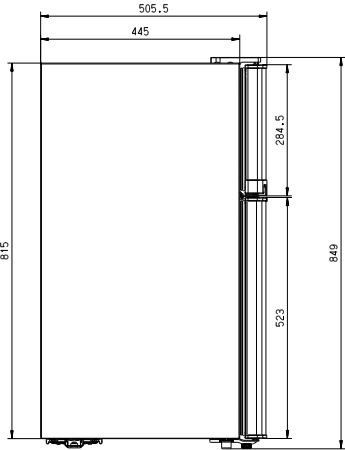
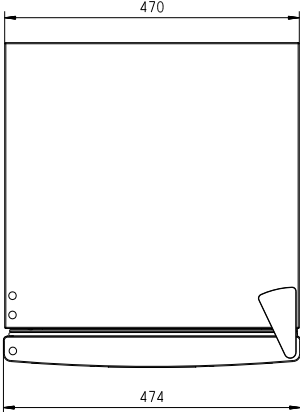
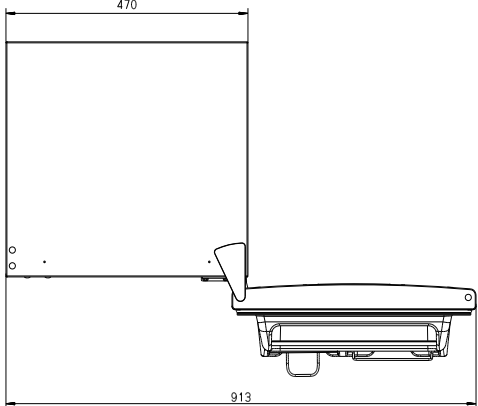
Front view	Side view
	
Down view	Maximum open angle of door(180°)
	

(The picture is only for reference, and specific appearance and configuration are subject to the real product)

7. Refrigerating piping system and circulating route of cooling air

7.1 Refrigerating piping system

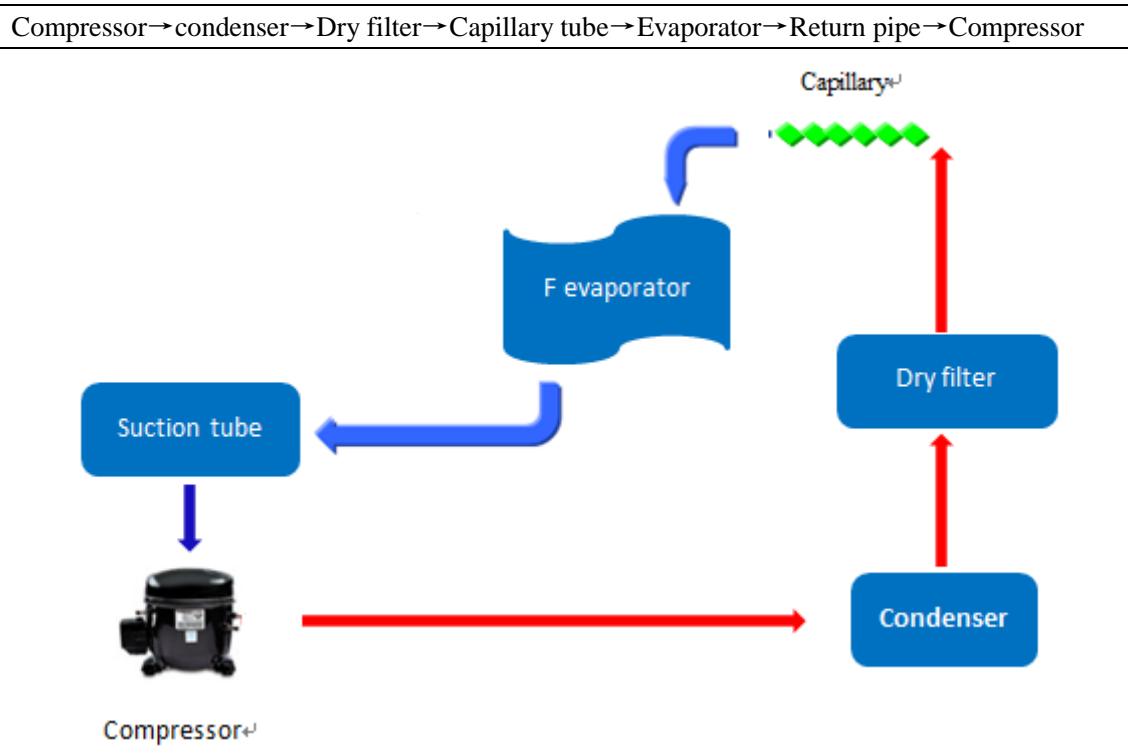

(The picture is only for reference, and specific appearance and configuration are subject to the real product)

7.2 Circulating route of cooling air (None)

8. Dismantling of parts

8.1 Parts on the door

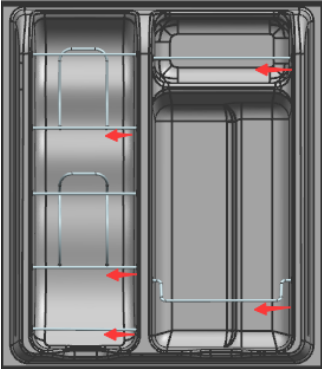
<p>Door seal</p> <p>Door seal is installed into door liner groove.</p> <ol style="list-style-type: none"> 1) Open the refrigerator door; 2) Take the door seal out of door liner; 		
<p>Guardrail</p> <p>Picture direction, move to one side, take out the other side.</p>		

8.2 Parts inside the refrigerator

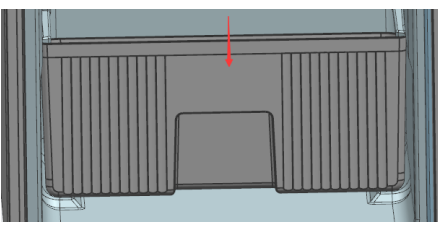
<p>Shelves</p> <ol style="list-style-type: none"> 1) move up 2) outward pulling the shelve at horizontal 		
<p>Drawer</p> <ol style="list-style-type: none"> 1) outward pulling the drawer at horizontal 		

8.3 Light system(None)



8.4 Air duct components refrigerating chamber

Air duct components refrigerating chamber	None
---	------



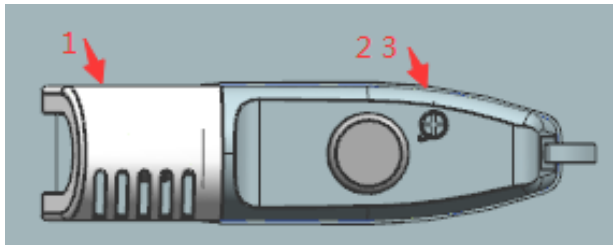

8.5 Air duct components in freezing chamber and fan motor

Disassembly and installation of Air duct	None
Fan motor of air duct	None

8.6 Evaporator and temperature sensing system

Evaporator in freezing chamber	not replace
Components on the evaporator	
Defrost thermostat	None
Fuse	None
Defrost sensor	None
Defrost heater	None
Evaporator in refrigerating chamber	None
Components on the evaporator	None
Sensor	
Sensor in freezing chamber	None
Sensor in refrigerating chamber	None
Sensor in Variable temperature chamber	None
ambient temperature senser	None
Thermostat	
Remove the lamp cover and insert pin, remove the screw under insert pin, outward pulling the thermostat-control box at horizontal	
pull out the knod,remove the socket the terminal,replace the thermostat	

8.6 Compressor case

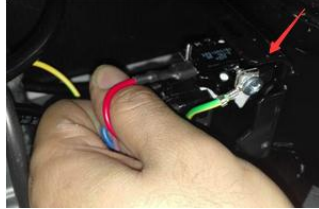
Piping system in the compressor case	
	
<p>1.compressor 2.left condenser 3.dry filter 4.suction pipe</p>	<p>5.right condenser</p>
Starter and protector of the compressor	
<p>1. Remove the screws 1) Two screws outside 2) One screw inside</p>	
<p>2. Remove the clipping strip Slowly pull it out</p>	
<p>3. Remove the protective cover 1) Pry the protective cover slowly from the upper part, 2) Pull it out and remove it.</p>	
<p>4. Remove the starter and protector Unplug the starter and protector (you can use a screwdriver to pry it slowly)</p>	
<p>5. The reverse process can complete installation.</p>	

8.7 Display and main control panel(None)

Display control board	None
-----------------------	------

Main control board	None
--------------------	------

8.8 Bar counter(None)

Disassembly and installation of bar counter	None
Disassembly and installation bar doorseal	None

8.9 Water dispenser(None)

Disassembly and installation of water valve	None
Disassembly and installation of water tank	None

8.10 Ice maker(None)

Disassembly and installation of ice maker	None
Disassembly and installation of water system	None
Disassembly and installation ice machine sensor	None

9. Function and operation

9.1 Operation panel

Direct cooling mechanical refrigerator, through the thermostat knob to adjust the stalls.

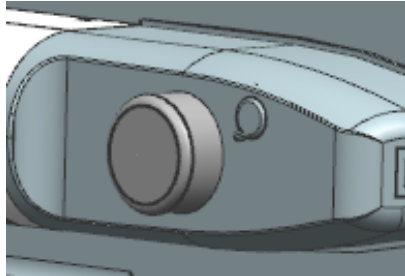

9.2 Temperature control

Turn the temperature control knob to MAX, the internal temperature of the refrigerator becomes lower.

Turn the temperature control knob to MIN, the internal temperature of the refrigerator becomes higher.

NOTE: Please adjusting and using between "MAX" and "MIN"

9.3 Give an alarm (None)

9.4 Failure code and solutions (None)

9.5 Defrost function

Manual defrost

9.6 Compressor fan control (None)

9.7 Test mode (None)

9.8 Self-diagnosis (None)

10.Circuit description

10.1 Power Supply(None)

10.2 Test circuit for door switch(None)

10.3 Temperature test circuit(None)

10.4Freezer chamber fan motor circuit (None)

10.5refrigerating chamber fan motor circuit (None)

10.6Condensation fan circuit (None)

10.5 Fan motor circuit of the ventilation door(None)

10.6Resistance value of the sensor (R/T) (None)

11. Troubleshooting Method

11.1 Not cooling

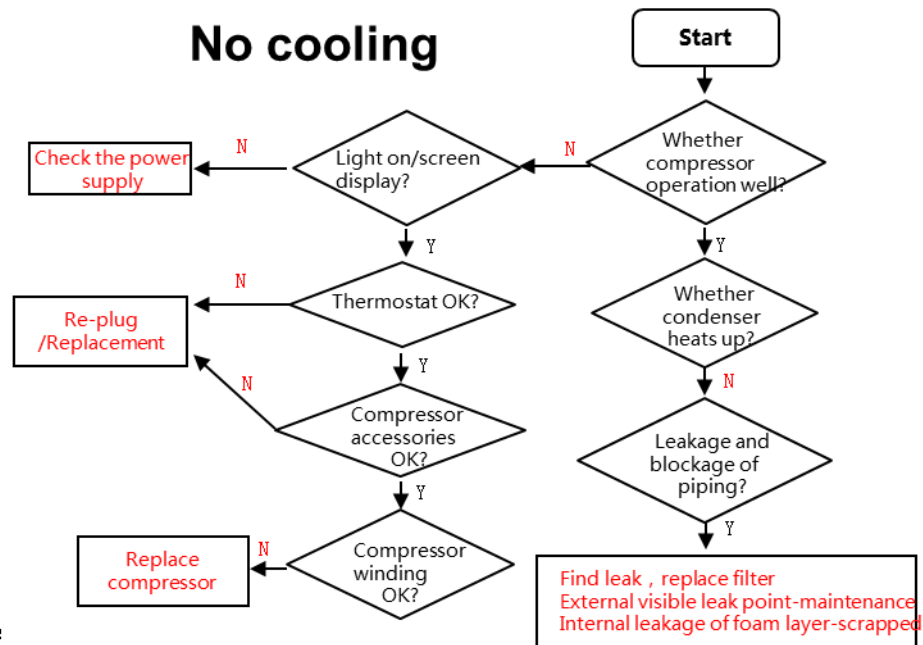

PTC: 16~50Ω
 Rmc: 10~20Ω
 Rsc: 30~50Ω
 Rms=Rmc+Rsc

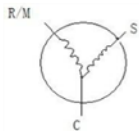

Common phenomenon of no cooling :

- The connector has a leak or the terminals are loose.
- Defective protector or starter.
- The connector is reversed, the timer is connected to the wrong line, or the timer is not reset.
- The leakage of the refrigeration system, welding plugs, the capillary depth of the dryer is not enough lead to solder plug.

11.2 Not working of compressor

No working of compressor

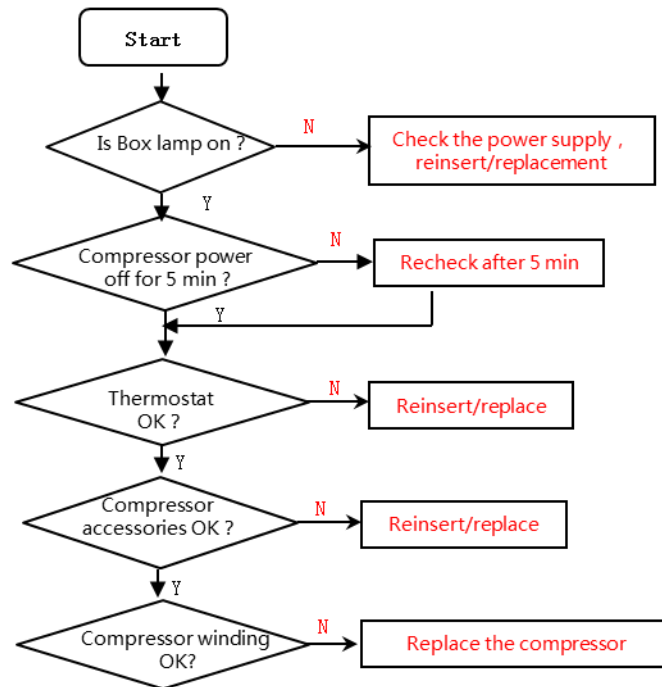

11.3 -Thermostat malfunction-Undercooling

Thermostat malfunction-Undercooling

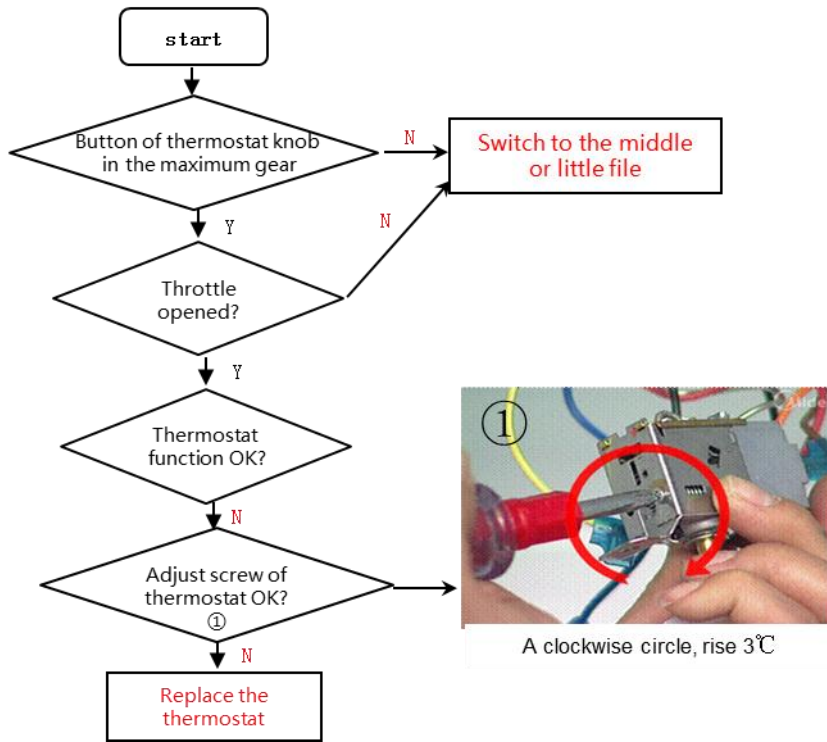

11.4 Noise

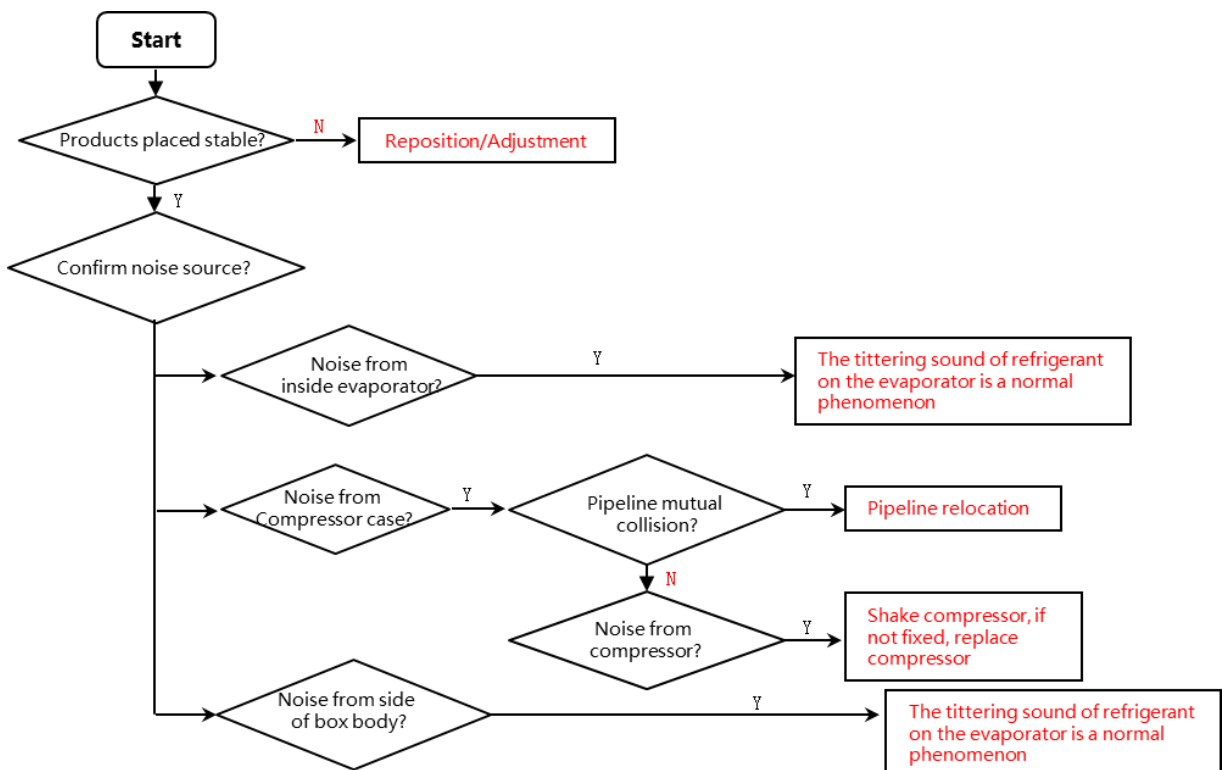

12. Figures and details of repair parts(Documentsareprovidedseparately)

12.1 Figures

12.2 List of parts and components



13Appendix:

13.1Electrical Schematic Diagram(None)

(Model: ***)

13.2Refrigerator maintenance tooling and equipment and material

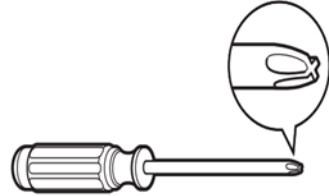
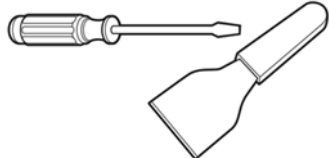
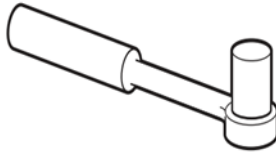

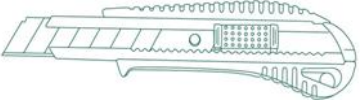

Tooling

No.	Name	Photo	Main Usage
1	Phillips screwdriver		screw assemble and disassemble
2	slotted screwdriver/scrapper		screw and rivet assemble and disassemble
3	Socket spanner 5/16"		hinge and compressor screw assemble and disassemble
4	Sucker		display panel and air duct cover disassemble
5	Allen wrench (2.8~4mm)		handle assemble and disassemble

6	Vise grip pliers		sealing process tube
7	Pipe cutter		pipe cutting
8	Knife		assistive tool
9	Nipper pliers		assistive tool
10	Capillary tube scissors		Shear capillary





Equipment

No.	Name	Photo	Main Usage
1	Vacuum pump		vacuum pumping

2	Electronic scale		weighing refrigerant/gas
3	High pressure nitrogen with piezometer		pipe and cooling system(condenser, evaporator, etc) impurities clean
4	Soldering gun		heating and welding
5	Quick coupling		connection process pipeline, vacuum or charge refrigerant will be used.
6	hand leak detector		welding point leakage detect, if no, use soap-suds

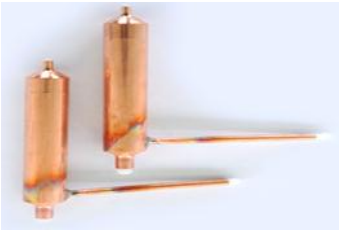
material

No.	Name	Photo	Main Usage
1	Process pipeline		Charge therefrigerant

2	Dry filter		Involving a system failure to be replaced
3	Copper welding rod		tube welding
4	Refrigerant/gas		Add refrigerant to the system
5	Sealing tape		door fixing for reversible door option

Midea Refrigerators

If you need to get detailed technical information from the manufacturer, please contact:

xxx@midea.com

Refrigeration Division

Overseas Sales Company

Address: No. 176, Jinxiu Avenue, Economic-Technological Development Area, Hefei, Anhui,
China