

Littlewood-Richardson Coefficients via Yang-Baxter Equation

Oleg Gleizer and Alexander Postnikov

1 Introduction

This paper presents an interpretation for the Littlewood-Richardson coefficients in terms of a system of quantum particles. Our approach is based on a certain scattering matrix that satisfies a Yang-Baxter-type equation. The corresponding piecewise-linear transformations of parameters give a solution to the tetrahedron equation. These transformation maps are naturally related to the dual canonical bases for modules over the quantum enveloping algebra $U_q(\mathfrak{sl}_n)$. A byproduct of our construction is an explicit description for Kashiwara's parametrizations of dual canonical bases. This solves a problem posed by Berenstein and Zelevinsky. We present a graphical interpretation of the scattering matrices in terms of web functions, which are related to honeycombs of Knutson and Tao.

The aim of this paper is to further investigate the Grothendieck ring K_N of polynomial representations of the general linear group $GL(N)$. Let V_λ be the irreducible representation of $GL(N)$ with highest weight λ . The structure constants $c_{\lambda\mu}^\nu$ of the Grothendieck ring in the basis of irreducible representations are given by

$$V_\lambda \otimes V_\mu = \sum_{\nu} c_{\lambda\mu}^\nu V_\nu.$$

We also mention several alternative interpretations for the numbers $c_{\lambda\mu}^\nu$. These numbers are

- the structure constants of the ring of symmetric polynomials in the basis of Schur polynomials;
- the coefficients of the decomposition into irreducibles of representations of

Received 22 February 2000.

Communicated by Andrei Zelevinsky.

symmetric groups induced from parabolic subgroups;

- the structure constants of the cohomology ring of a Grassmannian in the basis of Schubert classes.

The celebrated Littlewood-Richardson rule (see, e.g., [8]) is an explicit combinatorial description of the coefficients $c_{\lambda\mu}^\nu$. Several variations of this rule are known, including Zelevinsky pictures and Berenstein-Zelevinsky triangles [2].

In this paper we present a new interpretation of the Grothendieck ring K_N and the Littlewood-Richardson coefficients $c_{\lambda\mu}^\nu$. Our construction is based on the scattering matrix $R(c)$ that acts in the tensor square of the linear space E with the basis e_0, e_1, e_2, \dots by

$$R(c) : e_x \otimes e_y \mapsto \begin{cases} e_{y+c} \otimes e_{x-c} & \text{if } c \geq x - y, \\ 0 & \text{otherwise.} \end{cases}$$

(We assume that $e_x = 0$ whenever $x < 0$.) We denote by $R_{ij}(c)$ the operator acting on $E^{\otimes m}$ as $R(c)$ on the i th and j th copy of E and as an identity elsewhere. The tensor product of two irreducible representations V_λ and V_μ can be written as a certain combination of the operators $R_{ij}(c)$.

Using the operators $R_{ij}(c)$ we define a new bilinear operation “ $*$ ” on the tensor algebra $T(E)$ that corresponds to the operation of the tensor product of representations of $GL(N)$. It is straightforward that a Pieri-type formula holds for the $*$ -product of any basis element in $T(E)$ with e_k . The proof of the statement that tensor product $V_\lambda \otimes V_\mu$ is given by the $*$ -product easily follows from this fact and the fact that “ $*$ ” is an associative operation.

The associativity of the $*$ -multiplication is obtained from the following Yang-Baxter-type relation for the scattering matrices. The operators $R_{12}(c_{12})$, $R_{13}(c_{13})$, and $R_{23}(c_{23})$ acting on $E^{\otimes 3}$ satisfy the relation

$$R_{23}(c_{23})R_{13}(c_{13})R_{12}(c_{12}) = R_{12}(c'_{12})R_{13}(c'_{13})R_{23}(c'_{23}),$$

where c_{12} , c_{13} , and c_{23} are arbitrary parameters and c'_{12} , c'_{13} , and c'_{23} are given by the following piecewise-linear formulas:

$$\begin{aligned} c'_{12} &= \min(c_{12}, c_{13} - c_{23}), \\ c'_{13} &= c_{12} + c_{23}, \\ c'_{23} &= \max(c_{23}, c_{13} - c_{12}). \end{aligned} \tag{1.1}$$

Surprisingly, the same piecewise-linear transformations arise in the theory of dual canonical bases for the modules over the quantum enveloping algebra $U_q(\mathfrak{sl}_n)$

(see [3], [4]). For a fixed reduced decomposition of the longest element w_o in the symmetric group S_n , elements of the dual canonical basis (also known as the string basis) are parameterized by $\binom{n}{2}$ -tuples of integers (strings) that belong to a certain string cone (Kashiwara's parametrization). Two parametrizations that correspond to reduced decompositions related by a Coxeter move are obtained from each other by the formulas (1.1).

The string cone was described in [3] for a certain reduced decomposition of w_o . The core of our construction lies in an explicit description of the string cone for any reduced decomposition. Thus we solve a rather nontrivial problem posed in [3].

We also present a graphical (or "pseudophysical") interpretation of the scattering matrices and their compositions in the language of web functions and "systems of quantum particles." Web functions are closely related to honeycombs of Knutson and Tao [7] and Berenstein-Zelevinsky triangles [2]. It is shown in [7] that integral honeycombs are in one-to-one correspondence with Berenstein-Zelevinsky patterns. We establish a simple "dual" correspondence between integral web functions and Berenstein-Zelevinsky patterns. This reveals the "hidden duality" of the Littlewood-Richardson coefficients under the conjugation of partitions.

We briefly outline the structure of the paper. In Section 2 we give some background on the representation theory of general linear groups, the Littlewood-Richardson coefficients, and the combinatorics of symmetric groups and reduced decompositions. In Section 3 we define the scattering matrices $R_{ij}(c)$ and formulate our rule for the Littlewood-Richardson coefficients. Section 4 is devoted to the Yang-Baxter-type relation for the scattering matrices. In Section 5 we define and study principal cones for any reduced decomposition of a permutation. In the case of the longest permutation, these cones are exactly the string cones of parametrizations of dual canonical bases. The associativity of the $*$ -product is deduced in Section 6. In Section 7 we define web functions and establish their relationship with the scattering matrices and Berenstein-Zelevinsky patterns.

2 Preliminaries

In this section we remind the reader of the basic notions and notation related to symmetric groups and representations of general linear groups.

2.1 Representations of general linear groups

Let us recall the basics of the representation theory of the general linear group $GL(N)$.

The general linear group $GL(N)$ is the automorphism group of the N -dimensional complex linear space \mathbb{C}^N . A complex finite-dimensional linear representation V of $GL(N)$ is called *polynomial* if the corresponding mapping $GL(N) \rightarrow \text{Aut}(V)$ is given by polynomial functions. An arbitrary holomorphic finite-dimensional representation is obtained by tensoring a polynomial representation with a determinant representation $g \mapsto \det^k(g)$ for suitable negative k .

An irreducible polynomial representation of $GL(N)$ is uniquely determined by its highest weight $\lambda = (\lambda_1, \dots, \lambda_N)$, which can be any integer element of the dominant chamber given by $\lambda_1 \geq \lambda_2 \geq \dots \geq \lambda_N \geq 0$. We denote by V_λ the irreducible representation with highest weight λ . Its degree is $|\lambda| = \lambda_1 + \dots + \lambda_N$.

The collection of polynomial representations of $GL(N)$ equipped with the operations of direct sum and tensor product has the structure of an abelian category. Let $K_N = K(GL(N))$ be the Grothendieck ring of this category. Degree of representations provides a natural grading on the ring K_N . Slightly abusing notation, we identify a representation with its image in the Grothendieck ring K_N .

The irreducible representations V_λ form a \mathbb{Z} -basis of K_N . Our primary interest is in the structure constants of K_N . In other words, we investigate the coefficients $c_{\lambda\mu}^\nu$ of the expansion of the tensor product of two irreducible representations into a direct sum of irreducibles:

$$V_\lambda \otimes V_\mu = \sum_{\nu} c_{\lambda\mu}^\nu V_\nu.$$

The weights $\omega_k = (1, \dots, 1, 0, \dots, 0)$ (with k ones) are called the *fundamental weights*. By convention, $\omega_0 = (0, \dots, 0)$. Every dominant weight λ can be written uniquely as a sum of fundamental weights $\lambda = \omega_{x_1} + \dots + \omega_{x_m}$, $1 \leq x_1 \leq \dots \leq x_m \leq N$. Actually, the numbers x_i are just parts of the partition λ' *conjugate* to λ ; that is, $\lambda' = (x_m, x_{m-1}, \dots, x_1)$.

The fundamental representation V_{ω_k} is the k th exterior power of the tautological representation of $GL(N)$. Pieri's formula gives an explicit rule for the tensor product of V_{ω_k} with an irreducible representation V_λ .

Proposition 2.1 (Pieri's formula). For $\lambda = \omega_{x_1} + \dots + \omega_{x_m}$, $1 \leq x_1 \leq x_2 \leq \dots \leq x_m \leq N$, we have

$$V_{\omega_k} \otimes V_\lambda = \sum V_\mu, \tag{2.1}$$

where the sum is over all $\mu = \omega_{y_1} + \dots + \omega_{y_{m+1}}$ satisfying the following interlacing conditions:

$$0 \leq y_1 \leq x_1 \leq y_2 \leq x_2 \leq \dots \leq y_m \leq x_m \leq y_{m+1} \leq N,$$

$$y_1 - x_1 + y_2 - x_2 + \cdots + y_m - x_m + y_{m+1} = k. \quad \square$$

The Grothendieck ring K_N is generated by the fundamental representations V_{ω_k} . This implies the following statement that is handy afterward.

Lemma 2.2. Suppose that \odot is a bilinear associative multiplication operation on the linear space K_N such that for any fundamental weight ω_k and any dominant weight λ the product $V_{\omega_k} \odot V_\lambda$ is given by Pieri’s formula (2.1) and $V_{(0,\dots,0)}$ is the identity element. Then \odot is the usual multiplication in K_N , which is the tensor product of representations. \square

Proof. We show that $V_\lambda \odot V_\mu = V_\lambda \otimes V_\mu$ by induction on the degree $|\lambda|$ of V_λ . First, $V_{(0,\dots,0)} \odot V_\mu = V_\mu$ by the condition of the lemma. Suppose that the statement is true for any V_λ with $|\lambda| < d$. For $|\lambda| = d$, we can express V_λ via the generators V_{ω_k} as $\sum V_{\omega_k} \otimes W_k$, where the W_k are degree $d - 1$ elements of K_N . Then, by the inductive hypothesis,

$$\begin{aligned} V_\lambda \odot V_\mu &= \left(\sum V_{\omega_k} \odot W_k \right) \odot V_\mu \\ &= \sum V_{\omega_k} \odot (W_k \odot V_\mu) \\ &= \sum V_{\omega_k} \otimes W_k \otimes V_\mu \\ &= V_\lambda \otimes V_\mu. \quad \blacksquare \end{aligned}$$

2.2 Symmetric group

Our constructions rely strongly on the combinatorics of reduced decompositions in the symmetric group S_n . This section is devoted to a brief account of this theory.

Let $s_a \in S_n$ be the adjacent transposition that interchanges a and $a + 1$. Then s_1, \dots, s_{n-1} generate the symmetric group S_n . The generators s_a satisfy the following Coxeter relations:

$$\begin{aligned} s_a^2 &= 1, \\ s_a s_b &= s_b s_a, \quad \text{for } |a - b| \geq 2, \\ s_a s_{a+1} s_a &= s_{a+1} s_a s_{a+1}. \end{aligned} \tag{2.2}$$

For a permutation $w \in S_n$, an expression $w = s_{a_1} s_{a_2} \cdots s_{a_l}$ of minimal possible length l is called a *reduced decomposition*, and $l = \ell(w)$ is the *length* of w . The corresponding sequence $\mathbf{a} = (a_1, a_2, \dots, a_l)$ is called a *reduced word* for w . Let $\mathcal{R}(w)$ denote the set of all reduced words for w . A pair (i, j) , $1 \leq i < j \leq n$, is called an *inversion* in w if $w(i) > w(j)$. By $I(w)$ we denote the set of all inversions of w . The number $|I(w)|$ of inversions in w is equal to its length $\ell(w)$.

Let w_o be the longest permutation in S_n given by $w_o(i) = n + 1 - i$. Then $I(w_o)$ is the set of all pairs $1 \leq i < j \leq n$. A total ordering " $<$ " of inversions (i, j) in $I(w_o)$ is said to be a *reflection ordering* if for any triple $i < j < k$ we have either

$$(i, j) < (i, k) < (j, k) \quad \text{or} \quad (j, k) < (i, k) < (i, j).$$

Also, for any $w \in S_n$, we say that a total ordering of inversions in $I(w)$ is a reflection ordering if it is a final interval of some reflection ordering of $I(w_o)$.

The set of all reflection orderings of $I(w)$ is in one-to-one correspondence with the set of reduced decompositions of w (cf. [6, Proposition 2.13]). Explicitly, for a reduced decomposition $w = s_{a_1} s_{a_2} \cdots s_{a_l}$, the sequence of pairs $(i_1, j_1) < \cdots < (i_l, j_l)$ such that $i_r = s_{a_1} s_{a_{l-1}} \cdots s_{a_{r+1}}(a_r)$ and $j_r = s_{a_1} s_{a_{l-1}} \cdots s_{a_{r+1}}(a_r + 1)$, $r = 1, \dots, l$, is a reflection ordering of $I(w)$. Moreover, every reflection ordering of $I(w)$ arises in this fashion.

Graphically, we represent a reduced decomposition by its *wiring diagram*, which is also called a *pseudoline arrangement*. For instance, the reduced decomposition $s_3 s_2 s_1 s_2$ of an element in S_4 is depicted by the diagram in Figure 1.

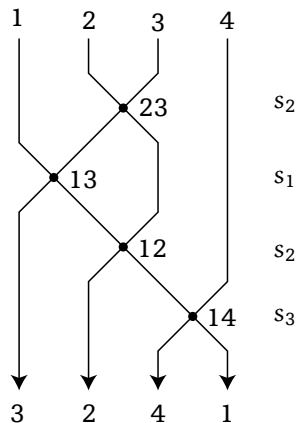

Figure 1

The nodes of this diagram correspond to the adjacent transpositions. On the other hand, each node is a crossing of i th and j th pseudolines, where (i, j) forms an inversion. Reading these pairs in the wiring diagram from bottom to top gives the corresponding reflection ordering of the inversions. In the example of Figure 1, the associated reflection ordering is $(1, 4) < (1, 2) < (1, 3) < (2, 3)$.

Applying the Coxeter relations to reduced decompositions results in the local transformations that are called 2- and 3-moves. Namely, 2-moves correspond to the

second equation in (2.2) and 3-moves to the third equation in (2.2). Two reduced decompositions of the same permutation are always connected by a sequence of 2- and 3-moves. Graphically, 2- and 3-moves can be represented by the local transformations of wiring diagrams in Figures 2 and 3, where $i < j < k < l$.

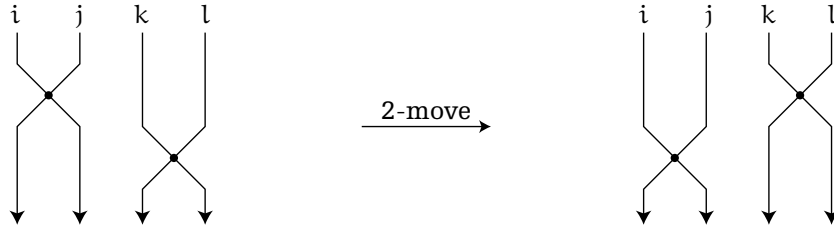

Figure 2

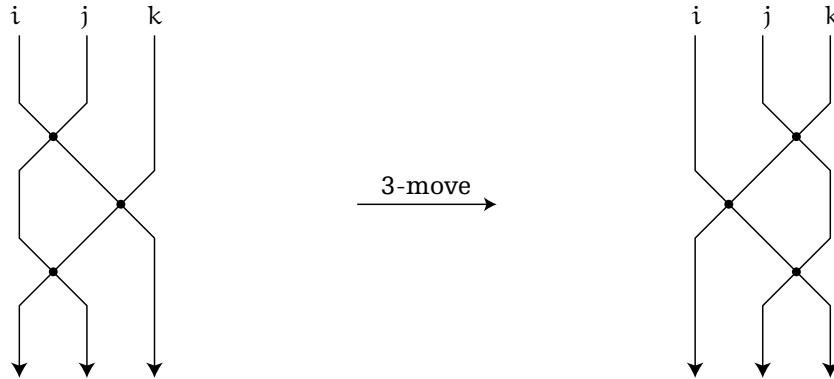

Figure 3

3 Scattering matrix

Let E be the linear space with a basis $e_x, x \in \mathbb{Z}_+$. We always assume that $e_x = 0$ for $x < 0$.

Definition 3.1. For $c \in \mathbb{Z}$, the *scattering matrix* $R(c)$ is the linear operator that acts on the space $E \otimes E$ by

$$R(c) : e_x \otimes e_y \mapsto \begin{cases} e_{y+c} \otimes e_{x-c} & \text{if } c \geq x - y, \\ 0 & \text{otherwise.} \end{cases} \quad (3.1)$$

The space E can be viewed as the space of states of a certain quantum particle. The basis vector e_x corresponds to a particle with energy level x . We think of the scattering

matrix $R(c)$ as the result of the interaction of two particles with energy levels x and y . Pictorially, we can represent it by the following “Feynman diagram” in Figure 4.

Notice that the energy conservation law holds in our model, since the sum of energies of particles after the interaction $(y + c) + (x - c)$ is the same as before the interaction.

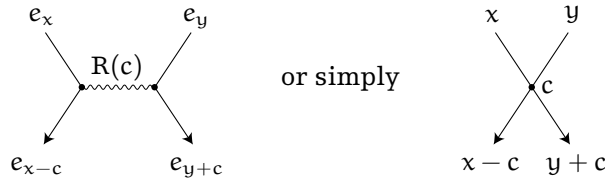

Figure 4 Operator $R(c)$.

By $R_{ij}(c)$ we denote the linear endomorphism of $E^{\otimes m} = E \otimes \dots \otimes E$ which acts as the transformation $R(c)$ on the i th and the j th copies of E and as an identity operator on other copies. Let $\mathbf{a} = (a_1, \dots, a_l)$ be a reduced word for $w \in S_n$, which is associated with the reduced decomposition $w = s_{a_1} s_{a_2} \dots s_{a_l}$, and let $(i_1, j_1) < \dots < (i_l, j_l)$ be the corresponding reflection ordering of the inversion set $I(w)$. For a collection $C = (c_{ij})$, $(i, j) \in I(w)$, of integer parameters, we define an endomorphism $R_{\mathbf{a}}(C)$ of $E^{\otimes m}$ as the composition of scattering matrices

$$R_{\mathbf{a}}(C) = R_{i_1 j_1}(c_{i_1 j_1}) R_{i_2 j_2}(c_{i_2 j_2}) \dots R_{i_l j_l}(c_{i_l j_l}). \tag{3.2}$$

It is clear that $R_{ij}(c_{ij})$ commutes with $R_{kl}(c_{kl})$ provided that all i, j, k , and l are distinct. Thus the composition $R_{\mathbf{a}}(C)$ stays invariant when we apply a 2-move to the reduced word \mathbf{a} .

For positive integers m and n , let $w(m, n)$ be the permutation from S_{m+n} given by

$$\begin{pmatrix} 1 & 2 & \dots & m & m+1 & m+2 & \dots & m+n \\ n+1 & n+2 & \dots & n+m & 1 & 2 & \dots & n \end{pmatrix}.$$

All reduced decompositions of the permutation $w(m, n)$ are related by 2-moves (cf. the diagram in Figure 5). Thus the map $R_{\mathbf{a}}(C)$ does not depend upon any particular choice of a reduced word \mathbf{a} for $w(m, n)$. We denote by $R_{(m,n)}(C)$ this endomorphism of $E^{\otimes m} \otimes E^{\otimes n}$. It depends upon the collection of mn parameters $C = (c_{ij})$, $1 \leq i \leq m < j \leq m+n$.

Let $T(E)$ denote the tensor algebra of the linear space E . We define a new bilinear operation $M : T(E) \otimes T(E) \rightarrow T(E)$ whose restriction $M_{m,n} : E^{\otimes m} \otimes E^{\otimes n} \rightarrow E^{\otimes(m+n)}$ is

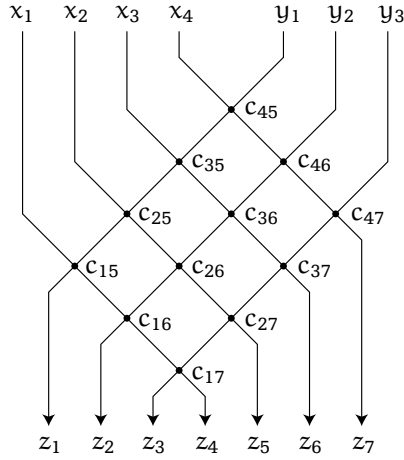

Figure 5 Operator $R(4, 3)$.

given by

$$M_{m,n} = \sum_C R_{(m,n)}(C), \tag{3.3}$$

where the sum is over all collections C of nonnegative integer parameters c_{ij} , $1 \leq i \leq m < j \leq m + n$, such that

$$c_{ij} \geq c_{kl} \text{ whenever } k \leq i < j \leq l. \tag{3.4}$$

We use the notation $A * B$ for $M(A, B)$, where $A, B \in T(E)$, and occasionally call this multiplication operation **-product*. Although the sum in (3.3) involves infinitely many terms, only a finite number of them are nonzero in the expansion for $A * B$.

Let us remark that a collection C of nonnegative integers that satisfy (3.4) is usually called a *rectangular-shaped plane partition*.

The composition of scattering matrices $R_{(m,n)}$ can be represented by the wiring diagram shown in Figure 5 (for $m = 4$ and $n = 3$). The summation in (3.3) is over all collections of nonnegative integer parameters c_{ij} that weakly decrease downward along the pseudolines of this diagram.

Theorem 3.2. The space $T(E)$ equipped with the multiplication operation M is an associative ring. □

Recall that $\omega_1, \dots, \omega_N$ are the fundamental weights of $GL(N)$. By convention, $\omega_0 = 0$.

Theorem 3.3. The projection $p_N : T(E) \rightarrow K_N$ defined on the basis elements by

$$p_N : e_{x_1} \otimes \cdots \otimes e_{x_m} \mapsto \begin{cases} V_\lambda, & \lambda = \omega_{x_1} + \cdots + \omega_{x_m}, \text{ provided } x_1 \leq x_2 \leq \cdots \leq x_m \leq N, \\ 0, & \text{otherwise,} \end{cases}$$

is a homomorphism from the ring $(T(E), M)$ to the Grothendieck ring K_N of polynomial representations of $GL(N)$. In other words, if $p_N(A) = V_\lambda$ and $p_N(B) = V_\mu$, then $p_N(A * B) = V_\lambda \otimes V_\mu$, the tensor product of representations. \square

Summarizing the above assertions and definitions, we can formulate a rule for the Littlewood-Richardson coefficients. Let us denote by $e_{x_1 \cdots x_m}$ the element $e_{x_1} \otimes \cdots \otimes e_{x_m} \in T(E)$.

Corollary 3.4. Let $\lambda = \omega_{x_1} + \cdots + \omega_{x_m}$, $\mu = \omega_{y_1} + \cdots + \omega_{y_n}$, and $\nu = \omega_{z_1} + \cdots + \omega_{z_{m+n}}$, where $x_1 \leq \cdots \leq x_m$, $y_1 \leq \cdots \leq y_n$, and $z_1 \leq \cdots \leq z_{m+n}$. The Littlewood-Richardson coefficient $c_{\lambda\mu}^\nu$ is equal to the number of collections C of nonnegative integers c_{ij} , $1 \leq i \leq m$, $m + 1 \leq j \leq m + n$, such that

$$c_{ij} \geq c_{kl}, \quad \text{for } i \leq k < l \leq j;$$

and

$$R_{(m,n)}(C) \cdot (e_{x_1 \cdots x_m} \otimes e_{y_1 \cdots y_n}) = e_{z_1 \cdots z_{m+n}}. \quad \square$$

Proposition 3.5. (1) We have $e_{x_1 \cdots x_m} * e_{y_1 \cdots y_n} = 0$ unless $x_1 \leq \cdots \leq x_m$ and $y_1 \leq \cdots \leq y_n$.

(2) The product $e_{x_1 \cdots x_m} * e_{y_1 \cdots y_n}$ involves only terms $e_{z_1 \cdots z_{m+n}}$ with $z_1 \leq \cdots \leq z_{m+n}$. \square

Proof. (1) First, we show that applying $R_{13}(c_{13})R_{23}(c_{23})$ to $e_{x_1} \otimes e_{x_2} \otimes e_{y_1}$ always results in zero, provided $c_{23} \geq c_{13}$ and $x_1 > x_2$. Indeed, we have $R_{13}(c_{13})R_{23}(c_{23}) \cdot (e_{x_1} \otimes e_{x_2} \otimes e_{y_1}) = R_{13}(c_{13}) \cdot (e_{x_1} \otimes e_{y_1+c_{23}} \otimes e_{x_2-c_{23}})$ (or zero). This expression is nonzero only if $c_{13} \geq x_1 - (x_2 - c_{23})$, that is, $c_{13} - c_{23} \geq x_1 - x_2$, which is a contradiction.

In general, suppose that, say, $x_i > x_{i+1}$. The composition of operators $R_{(m,n)}(C)$ with C satisfying (3.4) involves the fragment $R_{i+1\ m+1}(c_{i+1\ m+1})R_{i\ m+1}(c_{i\ m+1})$, where $c_{i+1\ m+1} \geq c_{i\ m+1}$. By the above argument, applying these operators gives zero.

(2) This statement follows by induction on m from Proposition 3.6. \blacksquare

Let us verify the statement of Theorem 3.3 for the $*$ -product of e_x with an arbitrary $e_{x_1 \cdots x_m}$. This product is given by the following Pieri-type formula.

Proposition 3.6. For $0 \leq x_1 \leq \cdots \leq x_m$, we have

$$e_x * e_{x_1 \cdots x_m} = \sum e_{y_1 \cdots y_{m+1}},$$

where the sum is over all y_1, \dots, y_{m+1} satisfying the following interlacing conditions:

$$\begin{aligned} 0 \leq y_1 \leq x_1 \leq y_2 \leq x_2 \leq \cdots \leq y_m \leq x_m \leq y_{m+1}, \\ y_1 - x_1 + y_2 - x_2 + \cdots + y_m - x_m + y_{m+1} = x. \end{aligned} \quad (3.5)$$

Proof. By definition, $e_x * e_{x_1 \cdots x_m} = \sum R_{1\ m+1}(c_m) R_{1\ m}(c_{m-1}) \cdots R_{12}(c_1) \cdot (e_x \otimes e_{x_1} \otimes \cdots \otimes e_{x_m})$, where the sum is over $c_1 \geq c_2 \geq \cdots \geq c_m \geq 0$. Each nonvanishing summand in the previous sum is equal to $e_{x-c_1} \otimes e_{x_1+c_1-c_2} \otimes e_{x_2+c_2-c_3} \otimes \cdots \otimes e_{x_{m-1}+c_{m-1}-c_m} \otimes e_{x_m+c_m}$, provided $c_1 \geq x - x_1$, $c_2 \geq (x_1 + c_1) - x_2$, $c_3 \geq (x_2 + c_2) - x_3$, and so on. Let us denote $y_1 = x - c_1$, $y_2 = x_1 + c_1 - c_2$, $y_3 = x_2 + c_2 - c_3$, \dots , $y_m = x_{m-1} + c_{m-1} - c_m$, $y_{m+1} = x_m + c_m$. Then all the above inequalities are equivalent to the interlacing conditions (3.5). ■

Due to Lemma 2.2 and Proposition 3.6, Theorem 3.3 and Corollary 3.4 would follow from Theorem 3.2, which says that M is an associative operation. The proof of associativity given in Section 6 is based on a Yang-Baxter-type relation for the scattering matrices $R_{ij}(c)$ (see Section 4) and on the construction of certain polyhedral cones in the space of the parameters c_{ij} (see Section 5).

4 Yang-Baxter equation and tetrahedron equation

As we mentioned before, for distinct i, j, k , and l , the endomorphism $R_{ij}(c_{ij})$ commutes with $R_{kl}(c_{kl})$. Thus $R_a(C)$ does not change when we apply a 2-move to the reduced word a . The relations that involve 3-moves are less trivial.

Theorem 4.1. The operators $R_{12}(c_{12})$, $R_{13}(c_{13})$, and $R_{23}(c_{23})$ acting on $E^{\otimes 3}$ satisfy the relation

$$R_{23}(c_{23}) R_{13}(c_{13}) R_{12}(c_{12}) = R_{12}(c'_{12}) R_{13}(c'_{13}) R_{23}(c'_{23}), \quad (4.1)$$

where c_{12} , c_{13} , and c_{23} are arbitrary parameters and c'_{12} , c'_{13} , and c'_{23} are given by

$$\begin{aligned} c'_{12} &= \min(c_{12}, c_{13} - c_{23}), \\ c'_{13} &= c_{12} + c_{23}, \\ c'_{23} &= \max(c_{23}, c_{13} - c_{12}). \end{aligned} \quad (4.2)$$

Moreover, for fixed c_{12} , c_{13} , and c_{23} , the collection c'_{12} , c'_{13} , and c'_{23} defined by (4.2) is a unique collection of parameters such that (4.1) holds identically. \square

In Figure 6, the two wiring diagrams related by a 3-move illustrate the statement of the theorem.

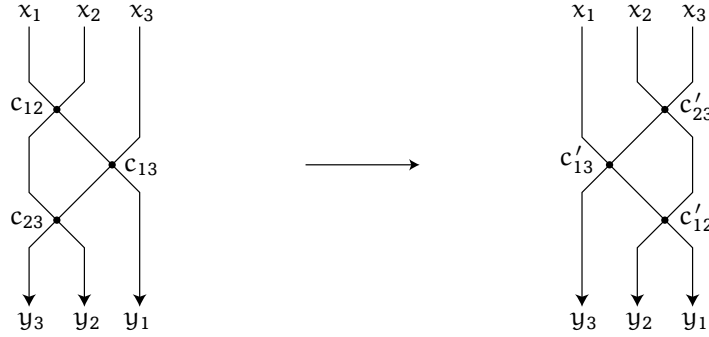

$$\begin{aligned} y_1 &= x_3 + c_{13} = x_3 + c'_{23} + c'_{12}, \\ y_2 &= x_2 + c_{12} - c_{13} + c_{23} = x_2 - c'_{23} + c'_{13} - c'_{12}, \\ y_3 &= x_1 - c_{12} - c_{23} = x_1 - c'_{13}. \end{aligned}$$

Figure 6

Remark 4.2. If $c_{13} = c_{12} + c_{23}$, then $c'_{12} = c_{12}$, $c'_{13} = c_{13}$, and $c'_{23} = c_{23}$. In this case, equation (4.1) becomes the famous *quantum Yang-Baxter equation* with two parameters, which is well known in the form $R_{12}(u)R_{13}(u+v)R_{23}(v) = R_{23}(v)R_{13}(u+v)R_{12}(u)$.

Proof of Theorem 4.1. The operator $R_{23}(c_{23})R_{13}(c_{13})R_{12}(c_{12})$ maps the basis vector $e_{x_1} \otimes e_{x_2} \otimes e_{x_3}$ either to $e_{x_3+c_{13}} \otimes e_{x_2+c_{12}-c_{13}+c_{23}} \otimes e_{x_1-c_{12}-c_{23}}$ if

$$\begin{cases} c_{12} \geq x_1 - x_2, \\ c_{13} \geq (x_2 + c_{12}) - x_3, \\ c_{23} \geq (x_1 - c_{12}) - (x_2 + c_{12} - c_{13}) \end{cases} \tag{4.3}$$

or to zero otherwise. Likewise, the operator $R_{12}(c'_{12})R_{13}(c'_{13})R_{23}(c'_{23})$ maps $e_{x_1} \otimes e_{x_2} \otimes e_{x_3}$ either to $e_{x_3+c'_{23}+c'_{12}} \otimes e_{x_2-c'_{23}+c'_{13}-c'_{12}} \otimes e_{x_1-c'_{13}}$ if

$$\begin{cases} c'_{23} \geq x_2 - x_3, \\ c'_{13} \geq x_1 - (x_2 - c'_{23}), \\ c'_{12} \geq (x_2 - c'_{23} + c'_{13}) - (x_3 - c'_{23}) \end{cases} \tag{4.4}$$

or to zero otherwise. These two operators are equal if and only if

$$\begin{aligned} c_{13} &= c'_{12} + c'_{23}, \\ c_{12} - c_{13} + c_{23} &= -c'_{23} + c'_{13} - c'_{12}, \\ c_{12} + c_{23} &= c'_{13} \end{aligned} \tag{4.5}$$

(the second identity is the difference of two others), and for any x_1, x_2, x_3 the condition (4.3) is equivalent to the condition (4.4). We can write these two sets of inequalities in a more compact form as

$$\begin{cases} \min(c_{12}, c_{23} + 2c_{12} - c_{13}) \geq x_1 - x_2, \\ c_{13} - c_{12} \geq x_2 - x_3, \end{cases}$$

which is equivalent to

$$\begin{cases} c'_{13} - c'_{23} \geq x_1 - x_2, \\ \min(c'_{23}, c_{12} + 2c'_{23} - c'_{13}) \geq x_2 - x_3. \end{cases}$$

Thus

$$\begin{aligned} \min(c_{12}, c_{23} + 2c_{12} - c_{13}) &= c'_{13} - c'_{23}, \\ c_{13} - c_{12} &= \min(c'_{23}, c_{12} + 2c'_{23} - c'_{13}). \end{aligned}$$

These two identities together with (4.5) are equivalent to the relations (4.2). ■

It follows for Theorem 4.1 that, for $i < j < k$, the operators $R_{ij}(c_{ij})$, $R_{ik}(c_{ik})$, and $R_{jk}(c_{jk})$ acting on $E^{\otimes n}$ satisfy the relation $R_{jk}(c_{jk})R_{ik}(c_{ik})R_{ij}(c_{ij}) = R_{ij}(c'_{ij})R_{ik}(c'_{ik})R_{jk}(c'_{jk})$, where

$$\begin{aligned} c'_{ij} &= \min(c_{ij}, c_{ik} - c_{jk}), \\ c'_{ik} &= c_{ij} + c_{jk}, \\ c'_{jk} &= \max(c_{jk}, c_{ik} - c_{ij}). \end{aligned} \tag{4.6}$$

The inverse transformation $(c'_{ij}, c'_{ik}, c'_{jk}) \rightarrow (c_{ij}, c_{ik}, c_{jk})$ is given by similar formulas

$$\begin{aligned} c_{ij} &= \max(c'_{ij}, c'_{ik} - c'_{jk}), \\ c_{ik} &= c'_{ij} + c'_{jk}, \\ c_{jk} &= \min(c'_{jk}, c'_{ik} - c'_{ij}). \end{aligned} \tag{4.7}$$

We denote by $\mathbb{Z}^{I(w)}$ the set of all collections of integer parameters $C = (c_{pq})$ with $(p, q) \in I(w)$, $p < q$. For $i < j < k$ such that $(i, j), (i, k), (j, k) \in I(w)$, we denote by T_{ijk} the local transformation of parameters

$$\begin{aligned} T_{ijk} : \mathbb{Z}^{I(w)} &\longrightarrow \mathbb{Z}^{I(w)}, \\ T_{ijk} : (c_{pq}) &\longmapsto (c'_{pq}), \end{aligned}$$

where the c'_{pq} are given by formulas (4.6) for $p, q \in \{i, j, k\}$ and $c'_{pq} = c_{pq}$ otherwise.

For any two reduced words $\mathbf{a}, \mathbf{b} \in \mathcal{R}(w)$ of a permutation $w \in S_n$, we define a transition map $T_{\mathbf{a}}^{\mathbf{b}} : \mathbb{Z}^{I(w)} \rightarrow \mathbb{Z}^{I(w)}$ as a composition of local transformation maps T_{ijk} . If $\mathbf{a} = (\dots, a, b, \dots)$ and $\mathbf{a}' = (\dots, b, a, \dots)$, $|a - b| \geq 2$, are two reduced words for w related by a 2-move, then $T_{\mathbf{a}}^{\mathbf{a}'}$ is the identity map. If $\mathbf{a} = (\dots, a, a + 1, a, \dots)$ and $\mathbf{a}' = (\dots, a + 1, a, a + 1, \dots)$ are two reduced words related by a 3-move, then the corresponding reflection orderings of $I(w)$ differ only in three places: $\dots < (j, k) < (i, k) < (i, j) < \dots$ and $\dots < (i, j) < (i, k) < (j, k) < \dots$ for certain $i < j < k$. In this case, we define $T_{\mathbf{a}}^{\mathbf{a}'} = T_{ijk}$ and $T_{\mathbf{a}'}^{\mathbf{a}} = T_{ijk}^{-1}$. In general, we choose a chain of reduced words $\mathbf{a}, \mathbf{a}^1, \mathbf{a}^2, \dots, \mathbf{a}^k, \mathbf{b} \in \mathcal{R}(w)$ that interpolates between \mathbf{a} and \mathbf{b} such that any two adjacent words are related by a 2- or 3-move. Then we define $T_{\mathbf{a}}^{\mathbf{b}} = T_{\mathbf{a}^k}^{\mathbf{b}} \cdots T_{\mathbf{a}^2}^{\mathbf{a}^1} T_{\mathbf{a}}^{\mathbf{a}^1}$.

It follows from the uniqueness part of Theorem 4.1 that the transition map $T_{\mathbf{a}}^{\mathbf{b}}$ does not depend upon a choice of path of 2- and 3-moves joining the reduced words \mathbf{a} and \mathbf{b} . Let us remark that this property amounts to verifying that the local transformation maps T_{ijk} satisfy the following tetrahedron equation.

Theorem 4.3 (Tetrahedron equation). Let w_o be the longest element in S_4 . The following identity for the compositions of maps $\mathbb{Z}^{I(w_o)} \rightarrow \mathbb{Z}^{I(w_o)}$ holds:

$$T_{123} T_{124} T_{134} T_{234} = T_{234} T_{134} T_{124} T_{123}. \quad \square$$

It is left as an exercise for the reader to verify directly that the local transformation maps T_{ijk} satisfy the tetrahedron equation.

Recall that $R_{\mathbf{a}}(C)$ is the composition of scattering matrices defined by (3.2). It is immediately clear from Theorem 4.1 that $R_{\mathbf{a}}(C) = R_{\mathbf{a}'}(T_{\mathbf{a}}^{\mathbf{a}'}(C))$ if \mathbf{a} and \mathbf{a}' are related by a 2- or 3-move. Thus, in general, we have

$$R_{\mathbf{a}}(C) = R_{\mathbf{b}}(T_{\mathbf{a}}^{\mathbf{b}}(C)) \tag{4.8}$$

for any two reduced words \mathbf{a} and \mathbf{b} for w and any collection of parameters $C \in \mathbb{Z}^{I(w)}$.

5 Principal cones

Let \mathbf{a} be a reduced word of a permutation $w \in S_n$. In this section we construct and study a certain polyhedral cone $\mathcal{C}_{\mathbf{a}}$ in the space $\mathbb{Z}^{I(w)}$. In the case when $w = w_o$ is the longest permutation in S_n , the cone $\mathcal{C}_{\mathbf{a}}$ is exactly the cone of Kashiwara’s parametrizations of dual canonical bases for $U_q(\mathfrak{sl}_n)$. It is the *string cone* in the terminology of Berenstein and Zelevinsky [3]. The explicit description of $\mathcal{C}_{\mathbf{a}}$ gives an answer to a question posed in [3].

5.1 Rigorous paths and statements of results

Let us fix a reduced word $\mathbf{a} \in \mathcal{R}(w)$ and an integer $0 \leq s \leq n$. We construct an oriented graph $G(\mathbf{a}, s)$ from the wiring diagram corresponding to \mathbf{a} as follows. Denote by v_{ij} the vertex of the wiring diagram which is the intersection of the i th and j th pseudolines. The vertex set of the graph $G(\mathbf{a}, s)$ is composed of the vertices v_{ij} together with $2n$ boundary vertices: U_1, \dots, U_n , which mark the upper ends of pseudolines from left to right, and L_1, \dots, L_n , which mark the lower ends of pseudolines from left to right. Notice that U_i is the upper end of the i th pseudoline. We orient downward the s pseudolines of the wiring diagram whose lower ends are labeled L_1, \dots, L_s , and we orient upward the remaining $n - s$ pseudolines whose lower ends are labeled L_{s+1}, \dots, L_n . Two vertices are connected by an edge in the graph $G(\mathbf{a}, s)$ if they are adjacent vertices on the same pseudoline. Directions of edges in $G(\mathbf{a}, s)$ agree with directions of the corresponding pseudolines. For example, the graph $G(121, 2)$ is shown in Figure 7.

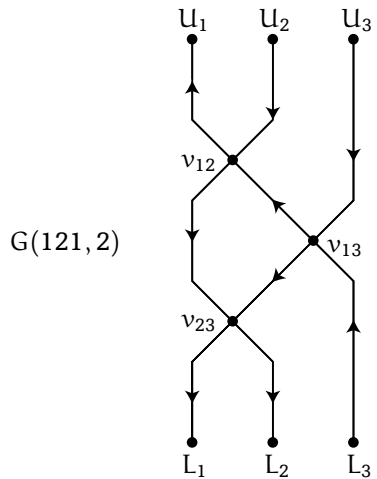

Figure 7

An oriented path in the graph $G(\mathbf{a}, s)$ is a sequence of vertices v_0, \dots, v_l connected by the oriented edges $v_0 \rightarrow v_1, v_1 \rightarrow v_2, \dots, v_{l-1} \rightarrow v_l$. Notice that the graph $G(\mathbf{a}, s)$ is acyclic; that is, there is no closed oriented cycle in the graph. Thus there are finitely many oriented paths in $G(\mathbf{a}, s)$. We say that an oriented path $v_0 \rightarrow v_1 \rightarrow \dots \rightarrow v_l$ is *rigorous* if it satisfies the following condition: There are no three adjacent vertices $v_a \rightarrow v_{a+1} \rightarrow v_{a+2}$ in the path such that v_a, v_{a+1} , and v_{a+2} belong to the same i th pseudoline, v_{a+1} is the intersection of the i th and j th pseudoline, and either $i < j$ and both i th and j th pseudolines are oriented upward, or $i > j$ and the i th and j th pseudolines are oriented downward. In other words, a path is rigorous if and only if it avoids the two fragments in Figure 8.



Figure 8

In Figure 8, the thick lines show path fragments and the thin lines show the pseudolines they intersect.

For example, in the graph $G(121, 2)$ shown in Figure 7 all paths connecting boundary vertices are rigorous except the following two paths: $L_3 \rightarrow v_{13} \rightarrow v_{23} \rightarrow L_1$ and $U_3 \rightarrow v_{13} \rightarrow v_{23} \rightarrow L_1$.

Let $P = (v_0 \rightarrow v_1 \rightarrow \dots \rightarrow v_l)$ be a rigorous path connecting two boundary vertices v_0 and v_l . Suppose that the edge $v_{r-1} \rightarrow v_r$ is on the i_r th pseudoline, for $r = 1, \dots, l$. We denote by c_P the expression

$$c_P = c_{i_1 i_2} + c_{i_2 i_3} + \dots + c_{i_{l-1} i_l}, \tag{5.1}$$

where we assume that $c_{ii} = 0$ and for $i > j$ the coefficients c_{ij} are given by $c_{ij} = -c_{ji}$.

Definition 5.1. For a reduced word $\mathbf{a} \in \mathcal{R}(w)$, we define the *principal cone* $\mathcal{C}_\mathbf{a}$ as the polyhedral cone in the integer lattice $\mathbb{Z}^{I(w)}$ of collections $C = (c_{ij})$ given by the inequalities $c_P \geq 0$ for all rigorous paths P in the graph $G(\mathbf{a}, s)$ from the vertex L_{s+1} to L_s , for $1 \leq s \leq n - 1$.

Theorem 5.2. For any two reduced words $\mathbf{a}, \mathbf{b} \in \mathcal{R}(w)$, the transition map $T_\mathbf{a}^\mathbf{b}$ bijectively maps the cone $\mathcal{C}_\mathbf{a}$ to the cone $\mathcal{C}_\mathbf{b}$. □

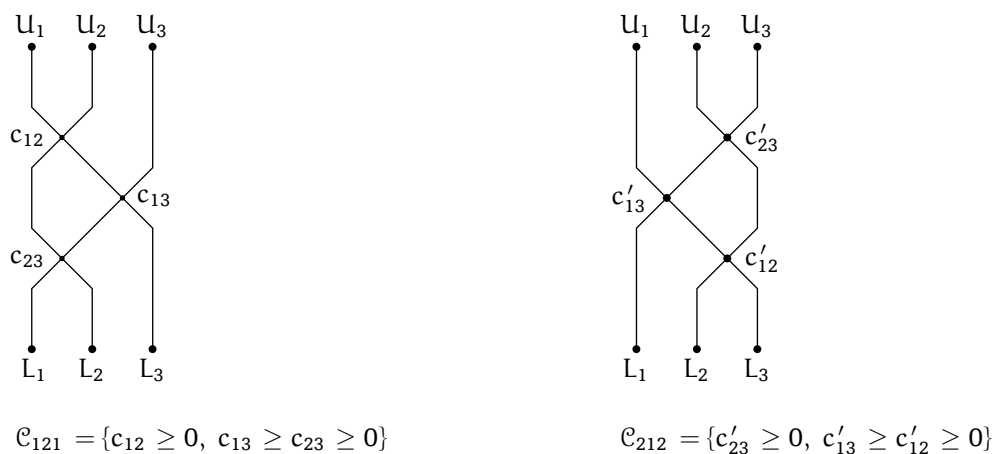

Figure 9

Example 5.3. To illustrate Definition 5.1 and Theorem 5.2, we describe in Figure 9 the principal cones for two reduced decompositions of w_0 in S_3 . Indeed, for $\mathbf{a} = 121$ we have the rigorous paths $L_2 \rightarrow v_{23} \rightarrow L_1, L_3 \rightarrow v_{13} \rightarrow v_{23} \rightarrow L_2$, and $L_3 \rightarrow v_{13} \rightarrow v_{12} \rightarrow v_{23} \rightarrow L_2$. Analogously, for $\mathbf{a} = 212$ we have the rigorous paths $L_2 \rightarrow v_{12} \rightarrow v_{23} \rightarrow v_{13} \rightarrow L_1$, $L_2 \rightarrow v_{12} \rightarrow v_{13} \rightarrow L_1$, and $L_3 \rightarrow v_{12} \rightarrow L_2$. One can easily verify that the transformation map T_{123} maps the cone \mathcal{C}_{121} into the cone \mathcal{C}_{212} .

In the case when $\mathbf{a} \in \mathcal{R}(w_0)$ is a reduced word for the longest permutation in S_n , there are two alternative descriptions of the principal cone $\mathcal{C}_\mathbf{a}$.

Theorem 5.4. For a reduced word $\mathbf{a} \in \mathcal{R}(w_0)$, the principal cone $\mathcal{C}_\mathbf{a}$ is the set of all collections $C = (c_{ij}) \in \mathbb{Z}^{I(w_0)}$ such that, for any reduced word $\mathbf{b} \in \mathcal{R}(w_0)$, all entries c'_{ij} of the collection $C' = (c'_{ij}) = T_\mathbf{a}^\mathbf{b}(C) \in \mathbb{Z}^{I(w)}$ are nonnegative. \square

For a reduced word $\mathbf{b} \in \mathcal{R}(w_0)$, let $\text{low}(\mathbf{b})$ denote the pair (i, j) , $1 \leq i < j \leq n$, such that the lowest node of the wiring diagram of \mathbf{b} is the crossing of i th and j th pseudolines. (It is clear that $j = i + 1$.) For example, $\text{low}(121) = (2, 3)$ and $\text{low}(212) = (1, 2)$.

The principal cone can be described by a weaker set of conditions as follows.

Theorem 5.5. For a reduced word $\mathbf{a} \in \mathcal{R}(w_0)$, the principal cone $\mathcal{C}_\mathbf{a}$ is the set of all collections $C = (c_{ij}) \in \mathbb{Z}^{I(w_0)}$ such that, for any reduced word $\mathbf{b} \in \mathcal{R}(w_0)$, the lowest entry $c'_{\text{low}(\mathbf{b})}$ of $C' = (c'_{ij}) = T_\mathbf{a}^\mathbf{b}(C)$ is nonnegative. \square

Remark 5.6. In the case of w_0 , we can choose either of the descriptions from Theorems 5.4 or 5.5 as the definition of the principal cone. Then Theorem 5.2 would become trivial. But this would obscure the fact that the principal cone is actually a polyhedral cone.

Before we proceed, let us consider several examples of principal cones.

Example 5.7. Let $\alpha_o = (1, 2, 1, 3, 2, 1, \dots, n - 1, n - 2, \dots, 1) \in \mathcal{R}(w_o)$ be the lexicographically minimal reduced word for the longest permutation. By Definition 5.1, the principal cone \mathcal{C}_{α_o} is given by the inequalities

$$\begin{aligned} c_{12} &\geq 0, \\ c_{13} &\geq c_{23} \geq 0, \\ c_{14} &\geq c_{24} \geq c_{34} \geq 0, \\ c_{15} &\geq c_{25} \geq c_{35} \geq c_{45} \geq 0, \dots \end{aligned} \tag{5.2}$$

Indeed, in this case all inequalities $c_p \geq 0$ in Definition 5.1 are of the form $c_{s\ s+1} \geq 0$ and $c_{s\ i} - c_{s+1\ i} \geq 0$ for $i > s + 1$.

Berenstein and Zelevinsky [3] studied the string cone of Kashiwara’s parametrizations of dual canonical basis for $U_q(\mathfrak{sl}_n)$. This is a cone $\tilde{\mathcal{C}}_{\alpha}$ in the $\binom{n}{2}$ -dimensional space of strings $C = (c_{ij})$ that depends upon a choice of reduced word $\alpha \in \mathcal{R}(w_o)$ for the longest permutation. It follows from the definitions that if α and α' differ by a 2- or 3-move, then $\tilde{\mathcal{C}}_{\alpha'} = T_{\alpha'}^{\alpha}(\tilde{\mathcal{C}}_{\alpha})$. Thus string cones $\tilde{\mathcal{C}}_{\alpha}$ transform according to the transition maps T_{α}^{β} . The string cone was explicitly calculated in [3] for the lexicographically minimal reduced word α_o . In this case $\tilde{\mathcal{C}}_{\alpha_o}$ is given by the inequalities (5.2). Theorem 5.2 and Example 5.7 imply the following statement.

Corollary 5.8 (String cones). For a reduced word $\alpha \in \mathcal{R}(w_o)$, the principal cone \mathcal{C}_{α} is exactly the string cone $\tilde{\mathcal{C}}_{\alpha}$. □

Definition 5.1 gives an explicit description of the string cone $\tilde{\mathcal{C}}_{\alpha}$. This settles the problem of describing the string cones for any reduced word $\alpha \in \mathcal{R}(w_o)$.

Example 5.9. This example is related to our construction of the $*$ -product in Section 3. Recall that the permutation $w(m, n) : i \mapsto i + n \pmod{m + n}$ in S_{m+n} has a unique reduced decomposition up to 2-moves. For example, for $m = 4$ and $n = 3$ we have the wiring diagram in Figure 10.

By Definition 5.1, the corresponding principal cone $\mathcal{C}_{(m,n)} = \mathcal{C}_{\alpha}$ is given by the inequalities $-c_{ik} + c_{ij} \geq 0$ for $i \leq m < j < k$, $c_{1\ m+n} \geq 0$, and $c_{jk} - c_{ik} \geq 0$ for $i < j \leq m < k$. These are exactly the conditions (3.4) on the parameters in the sum (3.3). Thus the $*$ -product in $T(E)$ can be written as the sum

$$e_{x_1 \dots x_m} * e_{y_1 \dots y_n} = \sum_{C \in \mathcal{C}_{(m,n)}} R_{(m,n)}(C) \cdot (e_{x_1 \dots x_m} \otimes e_{y_1 \dots y_n}).$$

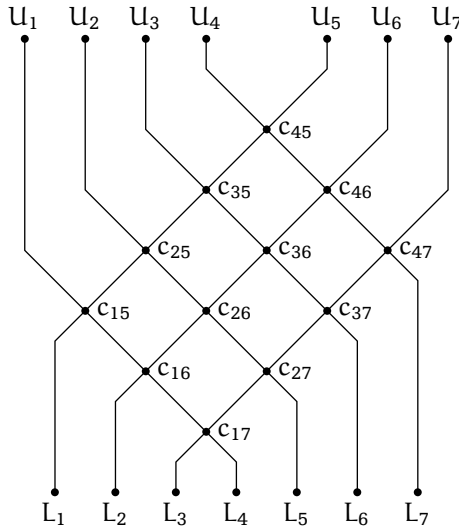

Figure 10

Example 5.10. Let us also illustrate the definitions by the example in Figure 11 for the reduced decomposition $s_2 s_1 s_2 s_3 s_2 s_1$ of the longest element $w_o \in S_4$.

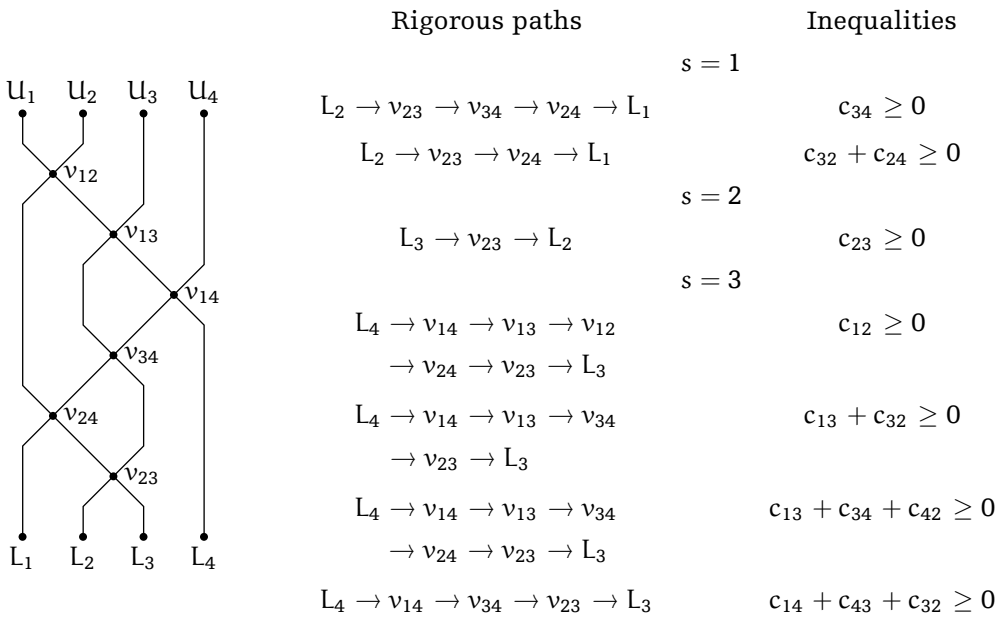

Figure 11

In more conventional notation the inequalities defining the cone \mathcal{C}_{212321} can be written as

$$\mathcal{C}_{212321} = \left\{ \begin{array}{l} c_{12} \geq 0 \\ c_{13} \geq c_{23} \geq 0 \\ c_{13} + c_{34} \geq c_{24} \geq c_{23} \\ c_{14} \geq c_{23} + c_{34} \\ c_{34} \geq 0 \end{array} \right\}.$$

To prove Theorems 5.2, 5.4, and 5.5, we need some extra notation. For two boundary vertices B and E in $\{U_1, \dots, U_n, L_1, \dots, L_n\}$, let

$$M_{B,E}^{\mathbf{a},s} = M_{B,E}^{\mathbf{a},s}(C) = \min_C c_P$$

be the minimum of expressions (5.1) over all rigorous paths P in the graph $G(\mathbf{a}, s)$ from the vertex B to the vertex E , here $C = (c_{ij})$. (Note that there are finitely many such paths.) If there are no rigorous paths from B to E in $G(\mathbf{a}, s)$, then we set $M_{B,E}^{\mathbf{a},s} = +\infty$.

Using this notation, Definition 5.1 of the principal cone can be written as

$$\mathcal{C}_{\mathbf{a}} = \{C \in \mathbb{Z}^{I(w)} \mid M_{L_{s+1}, L_s}^{\mathbf{a},s}(C) \geq 0, \text{ for } s = 1, \dots, n-1\}. \tag{5.3}$$

Theorem 5.2 is an immediate corollary of the following more general statement.

Theorem 5.11. For any two reduced words $\mathbf{a}, \mathbf{b} \in \mathcal{R}(w_o)$, an integer $0 \leq s \leq n$, and two boundary vertices B and E , we have $M_{B,E}^{\mathbf{a},s}(C) = M_{B,E}^{\mathbf{b},s}(C')$, where $C' = T_{\mathbf{a}}^{\mathbf{b}}(C)$. In other words, the expressions $M_{B,E}^{\mathbf{a},s}(C)$ are invariant under the transition maps $T_{\mathbf{a}}^{\mathbf{b}}$. \square

5.2 Proofs

Proof of Theorem 5.11. Let us first verify the statement of the theorem for the symmetric group S_3 . In this case we have only two reduced words 121 and 212 for w_o . There are four possible cases: $s = 0$, $s = 1$, $s = 2$, and $s = 3$.

Let us start with the case $s = 3$ when all pseudolines are oriented downward. The graphs $G(121, 0)$ and $G(212, 0)$ are given in Figure 12. We also give the transition maps T_{121}^{212} and its inverse T_{212}^{121} for a quick reference (cf. (4.2) and (4.7)).

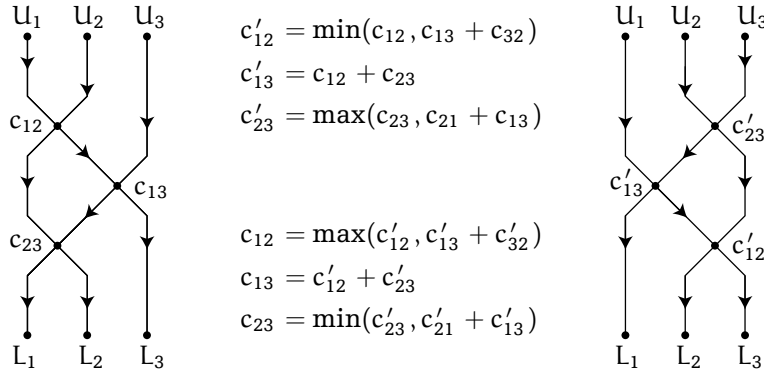

Figure 12

Enumerating rigorous paths in these graphs, we obtain

$$\begin{pmatrix} M_{U_1, L_1}^{121, 3} & M_{U_1, L_2}^{121, 3} & M_{U_1, L_3}^{121, 3} \\ M_{U_2, L_1}^{121, 3} & M_{U_2, L_2}^{121, 3} & M_{U_2, L_3}^{121, 3} \\ M_{U_3, L_1}^{121, 3} & M_{U_3, L_2}^{121, 3} & M_{U_3, L_3}^{121, 3} \end{pmatrix} = \begin{pmatrix} c_{12} + c_{23} & \min(c_{12}, c_{13} + c_{32}) & 0 \\ +\infty & c_{21} + c_{13} + c_{32} & c_{21} \\ +\infty & +\infty & c_{31} \end{pmatrix},$$

$$\begin{pmatrix} M_{U_1, L_1}^{212, 3} & M_{U_1, L_2}^{212, 3} & M_{U_1, L_3}^{212, 3} \\ M_{U_2, L_1}^{212, 3} & M_{U_2, L_2}^{212, 3} & M_{U_2, L_3}^{212, 3} \\ M_{U_3, L_1}^{212, 3} & M_{U_3, L_2}^{212, 3} & M_{U_3, L_3}^{212, 3} \end{pmatrix} = \begin{pmatrix} c'_{13} & c'_{12} & 0 \\ +\infty & c'_{23} + c'_{31} + c'_{12} & \min(c'_{21}, c'_{23} + c'_{31}) \\ +\infty & +\infty & c'_{32} + c'_{21} \end{pmatrix}.$$

It is immediate from the formulas for the transition maps T_{121}^{212} and T_{212}^{121} that these two matrices are equal to each other.

In the next case ($s = 2$) the pseudolines with the lower ends L_1 and L_2 are oriented downward, and the pseudoline with the lower end L_3 is oriented upward as shown in Figure 13.

In this case we have

$$\begin{pmatrix} M_{L_3, U_1}^{121, 2} & M_{L_3, U_2}^{121, 2} & M_{L_3, U_3}^{121, 2} \\ M_{U_2, U_1}^{121, 2} & M_{U_2, U_2}^{121, 2} & M_{U_2, U_3}^{121, 2} \\ M_{U_3, U_1}^{121, 2} & M_{U_3, U_2}^{121, 2} & M_{U_3, U_3}^{121, 2} \end{pmatrix} = \begin{pmatrix} 0 & \min(c_{12}, c_{13} + c_{32}) & c_{12} + c_{23} \\ c_{21} & 0 & c_{23} \\ c_{31} & \min(c_{32}, c_{31} + c_{12}) & c_{31} + c_{12} + c_{23} \end{pmatrix},$$

$$\begin{pmatrix} M_{L_3, U_1}^{212, 2} & M_{L_3, U_2}^{212, 2} & M_{L_3, U_3}^{212, 2} \\ M_{U_2, U_1}^{212, 2} & M_{U_2, U_2}^{212, 2} & M_{U_2, U_3}^{212, 2} \\ M_{U_3, U_1}^{212, 2} & M_{U_3, U_2}^{212, 2} & M_{U_3, U_3}^{212, 2} \end{pmatrix} = \begin{pmatrix} 0 & c'_{12} & c'_{13} \\ \min(c'_{21}, c'_{23} + c'_{31}) & 0 & \min(c'_{23}, c'_{21} + c'_{13}) \\ c'_{32} + c'_{21} & c'_{32} & c'_{32} + c'_{21} + c'_{13} \end{pmatrix}.$$

Again, it is clear that these two matrices are equal to each other.

The cases $s = 0$ and $s = 1$ are completely symmetric to the cases $s = 3$ and $s = 2$, respectively.

We can now verify the statement of the theorem for an arbitrary n . This general statement reduces to the case of S_3 ($n = 3$) as follows. Clearly, it is enough to prove the statement for two reduced words \mathbf{a} and \mathbf{a}' related by a 3-move. The corresponding reflection orderings of inversions differ only in three terms: $\dots < (j, k) < (i, k) < (i, j) < \dots$ and $\dots < (i, j) < (i, k) < (j, k) < \dots$ for some $i < j < k$. The transition map $T_{\mathbf{a}}^{\mathbf{a}'}$ is the map T_{ijk} that transforms c_{ij} , c_{ik} , and c_{jk} into c'_{ij} , c'_{ik} , and c'_{jk} according to formulas (4.6) and does not change other variables.

The intersection points of the pseudolines labeled i, j , and k form a subdiagram S in the wiring diagram of \mathbf{a} (resp., a subdiagram S' in the wiring diagram of \mathbf{a}') isomorphic to a wiring diagram for S_3 . Let us add six auxiliary vertices u_1, u_2, u_3 and l_1, l_2, l_3 to the graph $G(\mathbf{a}, s)$ (resp., in $G(\mathbf{a}', s)$) that mark the upper and lower ends of the pseudolines i, j , and k in this subdiagram.

If a path P in the graph $G(\mathbf{a}, s)$ does not pass through any of the vertices v_{ij}, v_{ik} , and v_{jk} , then the expression (5.1) for c_P does not change under the transformation map $T_{\mathbf{a}}^{\mathbf{a}'}$. Otherwise, the path P arrives to the subdiagram S via one of the six auxiliary points u_1, \dots, l_3 and leaves the subdiagram via another of these six points.

Let us fix two vertices b and e of the six auxiliary vertices and two rigorous paths P_1 (from B to b) and P_2 (from e to E). And let $\bar{M}_{b,e,P_1,P_2}^{\mathbf{a},s}(C)$ (resp., $\bar{M}_{b,e,P_1,P_2}^{\mathbf{a}',s}(C')$) be the minimum of the expressions c_P over rigorous paths P in $G(\mathbf{a}, s)$ (resp., in $G(\mathbf{a}', s)$) which are obtained by concatenation of the path P_1 , a rigorous path in S (resp., in S') from b to e , and the path P_2 . Then, by our definitions,

$$M_{B,E}^{\mathbf{a},s} = \min_{b,e,P_1,P_2} \bar{M}_{b,e,P_1,P_2}^{\mathbf{a},s} \quad \text{and} \quad M_{B,E,s}^{\mathbf{a}'} = \min_{b,e,P_1,P_2} \bar{M}_{b,e,P_1,P_2}^{\mathbf{a}',s}.$$



Figure 13

It follows from the case of S_3 considered above that $\bar{M}_{b,e,P_1,P_2}^a(C) = \bar{M}_{b,e,P_1,P_2}^{a'}(C')$. Therefore, $M_{B,E}^{a,s}(C) = M_{B,E}^{a',s}(C')$. This proves the theorem. ■

Proof of Theorem 5.5. Suppose that $\text{low}(\mathbf{b}) = (i, j)$, the lower end of i th pseudoline is L_{s+1} , and the lower end of j th pseudoline is L_s . (In the case of w_o we have $i = n - s$ and $j = n - s + 1$.) Then there is only one rigorous path in $G(\mathbf{b}, s)$ from L_{s+1} to L_s , namely, $L_{s+1} \rightarrow v_{ij} \rightarrow L_s$. In this case $M_{L_{s+1},L_s}^{b,s}(C') = c'_{ij}$. Thus $M_{L_{s+1},L_s}^{a,s}(C) = M_{L_{s+1},L_s}^{b,s}(C') = c'_{ij} = c'_{\text{low}(\mathbf{b})}$, where $C' = T_a^b(C)$.

For any $s = 1, \dots, n - 1$, there is a reduced decomposition \mathbf{b} of the longest permutation w_o such that $\text{low}(\mathbf{b}) = (n - s, n - s + 1)$. Thus the inequality $M_{L_{s+1},L_s}^{a,s}(C) \geq 0$ is equivalent to saying that, for any reduced word $\mathbf{b} \in \mathcal{R}(w_o)$ such that $\text{low}(\mathbf{b}) = (n - s, n - s + 1)$, the lowest entry $c'_{\text{low}(\mathbf{b})}$ of $C' = T_a^b(C)$ is nonnegative. The statement follows. ■

Proof of Theorem 5.4. We deduce this theorem from Theorem 5.5. Let us fix $\mathbf{a} \in \mathcal{R}(w_o)$. It is enough to show that if $C = (c_{ij})$ has a negative entry, then there is a reduced word $\mathbf{b} \in \mathcal{R}(w_o)$ such that the lowest entry $c'_{\text{low}(\mathbf{b})}$ of $C' = T_a^b(C)$ is negative.

Suppose not. Let us pick a reduced word \mathbf{b} such that $C' = T_a^b(C)$ has a negative entry $c'_{pq} < 0$ located on the lowest possible level. The pair $(p, q) \neq \text{low}(\mathbf{b})$ does not correspond to the lowest crossing in the wiring diagram of \mathbf{b} . Thus (possibly, after several 3-moves that do not affect c'_{pq}) we can make a 3-move transforming three entries $(c'_{ij}, c'_{ik}, c'_{jk}) \rightarrow (c''_{ij}, c''_{ik}, c''_{jk})$ by the rule (4.6) such that $(p, q) \in \{(i, j), (i, k), (j, k)\}$, but (p, q) is not the lowest pair (j, k) among these three. By our assumption, c'_{jk} is nonnegative. Then $c''_{ij} = \min(c'_{ij}, c'_{ik} - c_{jk})$ is negative, and c''_{ij} is located on a lower level in the resulting wiring diagram than the level of c'_{pq} in \mathbf{b} . This is a contradiction. ■

6 Associativity

In this section we prove Theorem 3.2, which claims that the $*$ -product defined by (3.3) is an associative operation.

Proof of Theorem 3.2. We need to verify that

$$(e_{x_1 \dots x_m} * e_{y_1 \dots y_n}) * e_{z_1 \dots z_k} = e_{x_1 \dots x_m} * (e_{y_1 \dots y_n} * e_{z_1 \dots z_k}), \tag{6.1}$$

for any positive m, n, k and $x_1 \leq \dots \leq x_m, y_1 \leq \dots \leq y_n, z_1 \leq \dots \leq z_k$.

Let Id_k be the identity permutation in S_k . The permutation $w(m, n) \times \text{Id}_k \in S_{m+n} \times S_k$ is canonically embedded into S_{m+n+k} . Likewise, the permutation $\text{Id}_m \times w(n, k) \in S_m \times S_{n+k}$ is canonically embedded into S_{m+n+k} . Then $w(m+n, k) \cdot (w(m, n) \times \text{Id}_k) = w(m, n+k) \cdot (\text{Id}_m \times w(n, k))$. We denote this permutation by $w(m, n, k)$.

Note that the permutations $w(m+n, k)$ and $w(m, n) \times \text{Id}_k$ have unique (up to 2-moves) reduced decompositions. Let \mathbf{a}^1 be a reduced word for $w(m, n, k)$ obtained by concatenation of reduced words for $w(m+n, k)$ and $w(m, n) \times \text{Id}_k$. Analogously, let \mathbf{a}^2 be a reduced word for $w(m, n, k)$ obtained by concatenation of reduced words for $w(m, n+k)$ and $\text{Id}_m \times w(n, k)$.

The inversion set $I(w(m, n, k))$ of the permutation $w(m, n, k)$ is the union of the following three sets of pairs: $[1, m] \times [m+1, m+n]$, $[1, m] \times [m+n+1, m+n+k]$, and $[m+1, m+n] \times [m+n+1, m+n+k]$, where $[a, b] = \{a, a+1, \dots, b\}$.

By the definition of $*$ -product, the left-hand side of the expression (6.1) is equal to the sum $\sum R_{\mathbf{a}^1}(C) \cdot (e_{x_1 \dots x_m} \otimes e_{y_1 \dots y_n} \otimes e_{z_1 \dots z_k})$ over all collections $C = (c_{ij}) \in \mathbb{Z}^{I(w(m, n, k))}$ with nonnegative integer entries such that

$$\begin{aligned} c_{ij} &\geq c_{pq} \quad \text{whenever } 1 \leq p \leq i \leq m, \quad m+1 \leq j \leq q \leq m+n, \\ c_{ij} &\geq c_{pq} \quad \text{whenever } 1 \leq p \leq i \leq m+n, \quad m+n+1 \leq j \leq q \leq m+n+k \end{aligned}$$

(cf. (3.4)). These are exactly the inequalities defining the principal cones $\mathcal{C}_{\mathbf{a}^1}$ (cf. Example 5.9). Thus the left-hand side of (6.1) can be written as

$$\sum_{C \in \mathcal{C}_{\mathbf{a}^1}} R_{\mathbf{a}^1}(C) \cdot (e_{x_1 \dots x_m} \otimes e_{y_1 \dots y_n} \otimes e_{z_1 \dots z_k}).$$

Analogously, the right-hand side of (6.1) can be written as

$$\sum_{C \in \mathcal{C}_{\mathbf{a}^2}} R_{\mathbf{a}^2}(C) \cdot (e_{x_1 \dots x_m} \otimes e_{y_1 \dots y_n} \otimes e_{z_1 \dots z_k}).$$

The equality of these two expressions follows from (4.8) and Theorem 5.2.

This proves Theorem 3.2 and thus completes the proof of our main statement concerning the $*$ -product (see Theorem 3.3). ■

7 Web functions, Berenstein-Zelevinsky triangles, and hidden duality

In this section we give a geometric interpretation of the scattering matrix (3.1) in terms of certain *web functions* as well as a “physical” motivation for it. Then we establish a relationship between integral web diagrams and fillings of Berenstein-Zelevinsky triangles. We also discuss the “hidden duality” of the Littlewood-Richardson coefficients under conjugation of partitions: $c_{\lambda\mu}^\gamma = c_{\lambda'\mu'}^{\gamma'}$.

7.1 Web functions

It is convenient to use the barycentric coordinates in \mathbb{R}^2 . Namely, we represent a point in \mathbb{R}^2 by a triple (α, β, γ) such that $\alpha + \beta + \gamma = 0$. We say that a line in \mathbb{R}^2 is of the *first* (resp., *second*, or *third*) type if its first (resp., second, or third) barycentric coordinate is fixed. We denote by $(a, *, *)$ the first-type line given by $\{(\alpha, \beta, \gamma) \mid \alpha + \beta + \gamma = 0, \alpha = a\}$. Analogously, we denote by $(*, b, *)$ and $(*, *, c)$ the lines of the second and third types given by $\{(\alpha, \beta, \gamma) \mid \alpha + \beta + \gamma = 0, \beta = b\}$ and $\{(\alpha, \beta, \gamma) \mid \alpha + \beta + \gamma = 0, \gamma = c\}$, respectively. Each of the two pictures in Figure 14 represents a union of three rays of first, second, and third type originating at the same point.

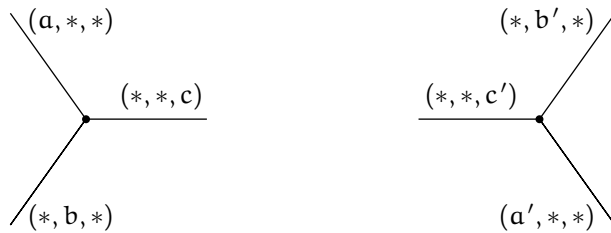

Figure 14

Notice that in both cases we have $a + b + c = 0$ and $a' + b' + c' = 0$. We say that these two types of sets are *left* and *right forks*. The central point of a fork is called its *node*. The node of the left (resp., right) fork shown in Figure 14 is the point (a, b, c) (resp., (a', b', c')) in the barycentric coordinates. We say that a function $f : \mathbb{R}^2 \rightarrow \mathbb{R}$ is a *fork function* (left or right) if there is a fork such that f is equal to 1 on three rays of the fork, to $3/2$ on its node, and zero everywhere else.

Definition 7.1. A *web function* is a function $f : \mathbb{R}^2 \rightarrow \mathbb{R}_+$ such that for every point in \mathbb{R}^2 there exists an open neighborhood U of the point, for which the restriction $f|_U$ is either zero, or the characteristic function of a line of one of three types, or a fork function (left or right), or a finite sum of several such functions. We say that a web function is *integral* if all its lines are of the form $(a, *, *)$, $(*, b, *)$, or $(*, *, c)$ with integers a , b , and c .

Geometrically, we represent a web function by a picture (called a *web diagram*) composed of rays and line segments of one of three types, and left or right forks (possibly doubled, tripled, and so on). See below for examples of web diagrams.

We say that a web function is *generic* if it only takes values 0, 1, and $3/2$. In other words, the diagram of a generic web function is composed of *noncrossing* rays, line segments, and forks. An arbitrary web diagram can be obtained by degeneration of a

generic web diagram, that is, by merging several lines, line intervals, and nodes together. For example, in Figure 15 the diagram on the left-hand side presents a generic web function. The diagram of a nongeneric web function on the right-hand side is obtained by merging three nodes together. The double line shows the locus where the web function is equal to 2.

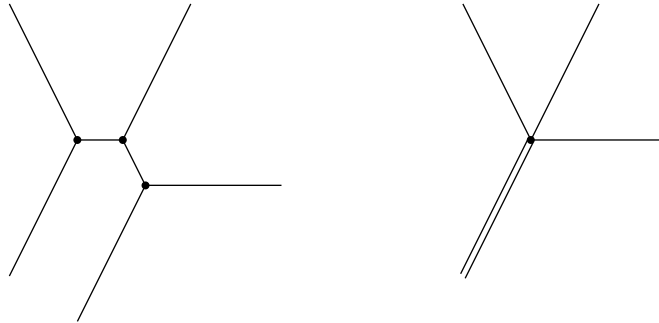

Figure 15

Each web diagram consists of several nodes, line intervals, semi-infinite rays, and/or infinite lines. We are only interested in web functions whose diagrams have finitely many nodes. We refer to semi-infinite rays in a web diagram as *boundary rays*. It is possible that the boundary rays are doubled (as in the example of Figure 15), tripled, and so on. The possible directions for boundary rays are *North-West* and *South-East* (for type-1 rays), *North-East* and *South-West* (for type-2 rays), and *West* and *East* (for type-3 rays), as shown in Figure 16.

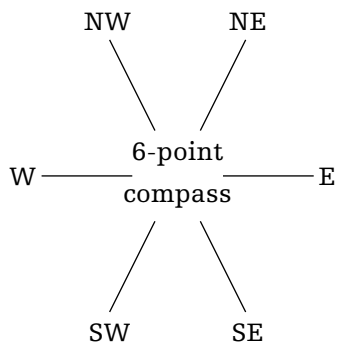

Figure 16

Recall that we defined the scattering matrix $R(c)$ by

$$R(c) : e_x \otimes e_y \mapsto \begin{cases} e_{y+c} \otimes e_{x-c} & \text{if } c \geq x - y, \\ 0 & \text{otherwise} \end{cases}$$

(see Definition 3.1). Here (unlike Section 3) we allow x , y , and c to be any real numbers.

The first-type line $(-x, *, *)$ can be thought of as the trajectory of a certain *left particle* of energy x . We denote this particle by $l(x)$. Analogously, the second-type line $(*, y, *)$ represents the trajectory of a *right particle* of energy y , denoted by $r(y)$. In both cases the trajectories go downward (from left to right for left particles and from right to left for right particles). Then the scattering matrix $R(c)$ represents an interaction of a left particle of energy x with a right particle of energy y . The web diagram in Figure 17 visualizes the scattering matrix $R(c)$. The horizontal segment in this diagram lies on the

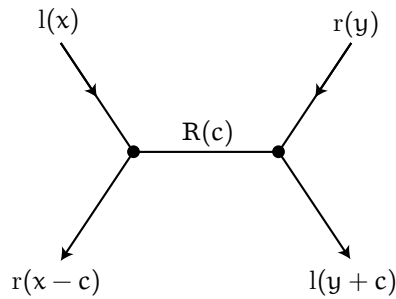

Figure 17

third-type line $(*, *, c)$. Thus the interaction $R(c)$ happens on the level c . The condition $c \geq x - y$ means that the interaction happens before the trajectories of the particles $l(x)$ and $r(y)$ cross each other.

Recall that in Section 3 we defined the operator $R_{(m,n)}((c_{ij}))$ as a composition of the scattering matrices $R_{ij}(c_{ij})$, $1 \leq i \leq m$, $m + 1 \leq j \leq m + n$. The operator $R_{(m,n)}((c_{ij}))$ applied to the vector $e_{x_1} \otimes \cdots \otimes e_{x_m} \otimes e_{y_1} \otimes \cdots \otimes e_{y_n}$ and producing the vector $e_{z_1} \otimes \cdots \otimes e_{z_{n+m}}$ can be represented by a web diagram, which is a combination of several pieces similar to the one shown in Figure 17. In our pseudophysical lexicon, this diagram represents an interaction of m left particles with n right particles. An example of such a web diagram for $m = 4$ and $n = 3$ is given in Figure 18.

In general, such a web diagram need not be as regular as the one shown in Figure 18. The edge lengths can be arbitrarily deformed.

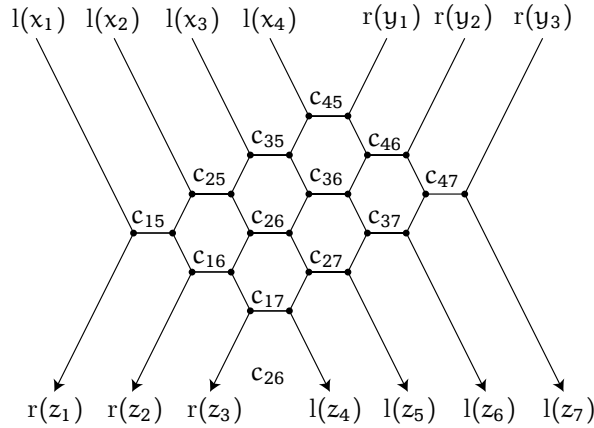

Figure 18

This web diagram has the following boundary rays: North-West rays, corresponding to incoming particles $l(x_1), \dots, l(x_m)$; North-East rays, corresponding to incoming particles $r(y_1), \dots, r(y_n)$; South-West rays, corresponding to outgoing particles $r(z_1), \dots, r(z_n)$; South-East rays, corresponding to outgoing particles $l(z_{n+1}), \dots, l(z_{n+m})$; and no East or West boundary rays. The i th left particle interacts with the j th right particle on the level c_{i+j} . In the web diagram, this interaction is represented by an interval that lies on the line $(*, *, c_{i+j})$. Such a web diagram is integral if and only if all x_i, y_j, z_k , and c_{ij} are integers.

Using the language of web diagrams, we derive the following statement from Corollary 3.4.

Corollary 7.2. Let $\lambda = \omega_{x_1} + \dots + \omega_{x_m}$, $\mu = \omega_{y_1} + \dots + \omega_{y_n}$, and $\nu = \omega_{z_1} + \dots + \omega_{z_{m+n}}$ be three dominant weights in $GL(N)$, where $1 \leq x_1 \leq \dots \leq x_m \leq N$, $1 \leq y_1 \leq \dots \leq y_n \leq N$, and $0 \leq z_1 \leq \dots \leq z_{m+n} \leq N$. The Littlewood-Richardson coefficient $c_{\lambda\mu}^\nu$ is equal to the number of integral web diagrams that have the following fixed boundary rays:

- the North-West rays $(-x_1, *, *)$, \dots , $(-x_m, *, *)$;
- the North-East rays $(*, y_1, *)$, \dots , $(*, y_n, *)$;
- the South-West rays $(*, z_1, *)$, \dots , $(*, z_n, *)$;
- the South-East rays $(-z_{n+1}, *, *)$, \dots , $(-z_{n+m}, *, *)$;
- no East or West boundary rays. □

Independently of our work a notion of a *honeycomb tinkertoy* recently appeared in [7] in relation to Klyachko’s saturation hypothesis. It is similar, though not quite identical, to our web diagram. (The origin of the term “honeycomb” should be clear from

Figure 18.) This tinkertoy is given along with a statement reminiscent of Corollary 7.2. In our notation this statement can be reformulated in the following theorem.

Theorem 7.3 [7, Theorem 1]. Let $\lambda = (\lambda_1, \dots, \lambda_N)$, $\mu = (\mu_1, \dots, \mu_N)$, and $\nu = (\nu_1, \dots, \nu_N)$ be three dominant weights of $GL(N)$. The Littlewood-Richardson coefficient $c_{\lambda\mu}^\nu$ is equal to the number of integral web diagrams with the following fixed boundary rays:

- the North-West rays $(\lambda_1, *, *)$, \dots , $(\lambda_N, *, *)$;
- the South-West rays $(*, \mu_1, *)$, \dots , $(*, \mu_N, *)$;
- the East rays $(*, *, -\nu_N)$, \dots , $(*, *, -\nu_1)$. □

In a sense, these two statements are dual to each other. The proof of Theorem 7.3 is based on a simple one-to-one correspondence (see [7, appendix]) between integral honeycomb tinkertoys (in our notation, web diagrams satisfying the conditions of Theorem 7.3) and Berenstein-Zelevinsky patterns [2]. This correspondence just assigns to such a web diagram the triangular array filled by lengths of edges of the diagram.

The Berenstein-Zelevinsky interpretation of the Littlewood-Richardson coefficients, among its many other virtues, makes it clear that these coefficients are symmetric with respect to the action of S_3 by permuting the three weights. Nevertheless this construction obscures the invariance of the Littlewood-Richardson coefficients under the conjugation of partitions: $c_{\lambda\mu}^\nu = c_{\lambda'\mu'}^{\nu'}$. This “hidden duality” can be observed from another even simpler bijection between web diagrams and Berenstein-Zelevinsky patterns, which is “dual” to the one given in [7, appendix]. To formulate the correspondence we have to rigorously define these patterns.

7.2 BZ-functions and BZ-triangles

We say that BZ-lattice \mathcal{L}_{BZ} is the set $((1/2)\mathbb{Z} \times (1/2)\mathbb{Z}) \setminus (\mathbb{Z} \times \mathbb{Z})$. Using the barycentric coordinates we can describe \mathcal{L}_{BZ} as the set of points (α, β, γ) , $\alpha + \beta + \gamma = 0$, such that 2α , 2β , and 2γ are integers but at least one α , β , or γ is not an integer.

Every integer point (a, b, c) , $a + b + c = 0$, has six neighbours in \mathcal{L}_{BZ} that form the vertices of the hexagon in Figure 19.

Definition 7.4. A function $f : \mathcal{L}_{BZ} \rightarrow \{0, 1, 2, \dots\}$ is called a BZ-function if for any hexagon, as in Figure 19, it satisfies the following *hexagon condition*:

$$\begin{aligned} f(A) + f(B) &= f(D) + f(E), \\ f(B) + f(C) &= f(E) + f(F), \\ f(C) + f(D) &= f(F) + f(A). \end{aligned}$$

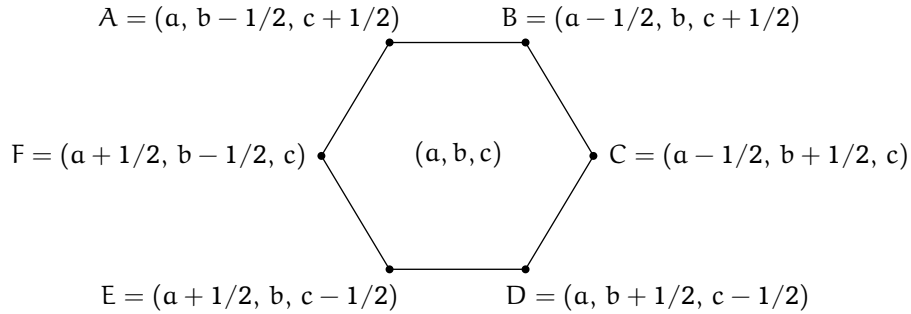

Figure 19

Proposition 7.5. Integral web functions are in one-to-one correspondence with BZ-functions. This correspondence κ is given by restricting a web function $f : \mathbb{R}^2 \rightarrow \mathbb{R}_+$ to the BZ-lattice \mathcal{L}_{BZ} :

$$\begin{aligned} \kappa : \{ \text{integral web functions} \}, &\longrightarrow \{ \text{BZ-functions} \}, \\ \kappa : f &\longmapsto f|_{\mathcal{L}_{\text{BZ}}}. \end{aligned} \quad \square$$

Proof. Restrictions of first-, second-, and third-type lines and of left and right forks to a hexagon are in Figure 20. It is clear that all five functions in Figure 20 satisfy the hexagon

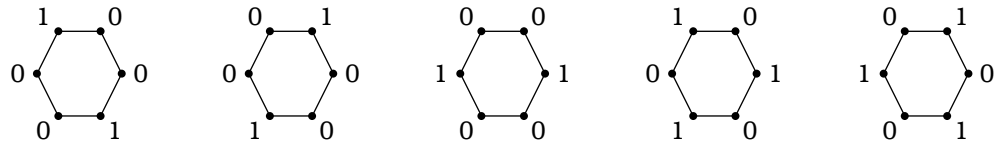

Figure 20

condition. It is also not hard to verify that any nonnegative integer function on a hexagon that satisfies the hexagon condition is a linear combination of these five functions with nonnegative integer coefficients. Thus restrictions of integral web functions to the BZ-lattice are BZ-functions, and every BZ-function can be obtained in such a way. On the other hand, an integral web function is determined by its values on \mathcal{L}_{BZ} . For example, the values in the center of the hexagon are equal to 1 for the first three functions in Figure 20 and equal to $3/2$ for the remaining two functions. ■

Let us fix an integer $N \geq 1$. The BZ-triangle T_N is the triangular subset in \mathcal{L}_{BZ} given by the inequalities $\alpha > -N$, $\beta > 0$, and $\gamma = -\alpha - \beta > 0$. A *Berenstein-Zelevinsky pattern* (BZ-pattern) of size N is the restriction of a BZ-function to the triangle T_N .

For example, a BZ-pattern of size 4 is an array of nonnegative integer numbers a_1, \dots, a_{18} (arranged in a triangle as shown in Figure 21) such that the numbers in any of the three hexagons satisfy the hexagon condition.

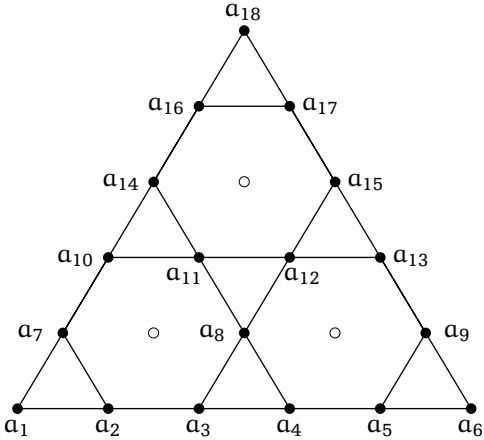

Figure 21 BZ-triangle T_4 .

For a BZ-pattern of size N , let a_1, \dots, a_{2N-2} be the number in the lower row, let b_1, \dots, b_{2N-2} be the numbers on its left side, and let c_1, \dots, c_{2N-2} be the numbers on its right side (in all cases we count the numbers from left to right). For the triangle in Figure 21, $b_1 = a_1, b_2 = a_7, b_3 = a_{10}, b_4 = a_{14}, b_5 = a_{16}, b_6 = a_{18}$, and $c_1 = a_{18}, c_2 = a_{17}, c_3 = a_{15}, c_4 = a_{13}, c_5 = a_9, c_6 = a_6$.

Berenstein and Zelevinsky [2] found the following interpretation of the Littlewood-Richardson coefficients in terms of BZ-patterns.

Theorem 7.6 [2]. Let λ, μ , and ν be three dominant weights for $GL(N)$ such that $|\lambda| + |\mu| = |\nu|$ and $\lambda = l_1 \omega_1 + \dots + l_N \omega_N, \mu = m_1 \omega_1 + \dots + m_N \omega_N$, and $\nu = n_1 \omega_1 + \dots + n_N \omega_N$. Then the Littlewood-Richardson coefficient $c_{\lambda\mu}^\nu$ is equal to the number of BZ-patterns of size N with the following boundary conditions:

$$\begin{aligned}
 l_1 &= b_1 + b_2, & l_2 &= b_3 + b_4, \dots, & l_{N-1} &= b_{2N-3} + b_{2N-2}, \\
 m_1 &= c_1 + c_2, & m_2 &= c_3 + c_4, \dots, & m_{N-1} &= c_{2N-3} + c_{2N-2}, \\
 n_1 &= a_1 + a_2, & n_2 &= a_3 + a_4, \dots, & n_{N-1} &= a_{2N-3} + a_{2N-2}.
 \end{aligned}$$

□

Proposition 7.5 says that web functions are essentially BZ-patterns of infinite size. Let us fix a set of boundary rays that satisfy the conditions of Corollary 7.2. Then an integral web function with these boundary rays is determined by its restriction to

T_N , which is a BZ-pattern. The conditions on the rays of such web functions transform into the boundary conditions for the BZ-patterns from Theorem 7.6. Thus Corollary 7.2 is equivalent to Theorem 7.6.

Proposition 7.7. Let λ , μ , and ν be three dominant weights for $GL(N)$ such that $|\lambda| + |\mu| = |\nu|$. The integral web functions that satisfy the conditions of Corollary 7.2 are in one-to-one correspondence with the BZ-patterns of size N that satisfy the boundary conditions of Theorem 7.6. This correspondence κ_N is given by restricting a web function $f : \mathbb{R}^2 \rightarrow \mathbb{R}_+$ to the BZ-triangle T_N :

$$\kappa_N : f \mapsto f|_{T_N}. \quad \square$$

Figure 22 illustrates the statement of Proposition 7.7. It shows a web diagram and the BZ-triangle T_{11} . In this case the corresponding BZ-pattern has 1's at the points that belong to the web diagram and it has 0's everywhere else.

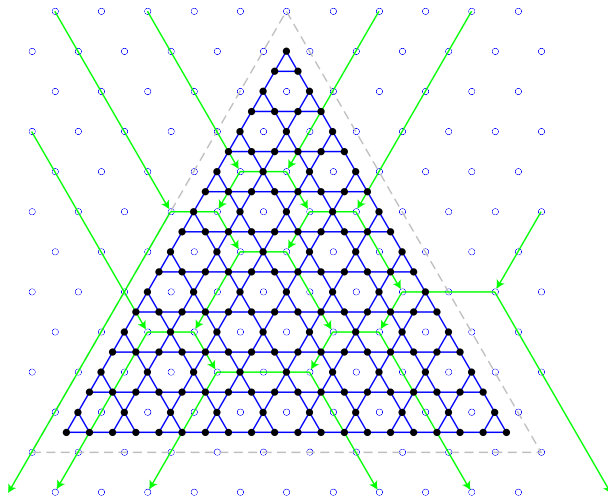

Figure 22 Web diagram and corresponding BZ-pattern.

8 Remarks and open questions

There are several questions that remained outside the scope of this paper. We briefly mention them here, and they will be properly illuminated in subsequent publications.

First of all, an open problem of interest is to describe explicitly the transformation maps T_a^b for any two reduced words for w (see Section 4).

There is an analogy between piecewise-linear transformations T_{ijk} given by (4.6) and the transformations for Lusztig's parametrization of the canonical basis in $U_q^+(\mathfrak{sl}_n)$. Lusztig's transformations were thoroughly investigated in [1]. The combinatorial essence of this work lies in a certain *chamber ansatz*. It would be interesting to find analogues of the results of [1].

In a recent paper [5], Berenstein and Zelevinsky investigated string cones and relations between Lusztig's and Kashiwara's parametrizations. It would be interesting to find a relationship between our combinatorial description of the string cone in terms of rigorous paths and their construction.

Following [1], it is possible to formulate the transition maps T_{ijk} and T_a^b in the language of the *tropical semiring*—a kind of algebraic system where one is allowed to add, multiply, and divide, but not subtract. Taking the presentation of the tropical multiplication by the usual addition, tropical division by the usual subtraction, and tropical addition by the operation \min , we can recover piecewise-linear combinatorics. On the other hand, taking the more natural presentation of the tropical multiplication by the usual multiplication, tropical division by the usual division, and tropical addition by the usual addition, we can move to the area of rational mathematics. Hopefully, the rational expressions corresponding to the piecewise-linear transition maps T_a^b can be presented by some determinant-like creatures.

Knutson and Tao [7] defined honeycombs as certain embeddings of certain graphs into \mathbb{R}^2 . They used honeycombs in the proof of Klyachko's saturation conjecture. Our web functions are related to honeycombs, but they are defined in a different way by means of local conditions. Sometimes this definition is more convenient. It is possible to give a proof to the saturation conjecture in terms of web functions which is simpler than Knutson and Tao's proof.

References

- [1] A. Berenstein, S. Fomin, and A. Zelevinsky, *Parametrizations of canonical bases and totally positive matrices*, Adv. Math. **122** (1996), 49–149.
- [2] A. Berenstein and A. Zelevinsky, *Triple multiplicities for $\mathfrak{sl}(r+1)$ and the spectrum of the exterior algebra of the adjoint representation*, J. Algebraic Combin. **1** (1992), 7–22.
- [3] ———, “String bases for quantum groups of type A_r ” in *I. M. Gelfand Seminar*, Adv. Soviet Math. **16**, Part 1, Amer. Math. Soc., Providence, 1993, 51–89.
- [4] ———, *Canonical bases for the quantum group of type A_r and piecewise-linear combinatorics*, Duke Math. J. **82** (1996), 473–502.
- [5] ———, *Tensor product multiplicities, canonical bases and totally positive varieties*, <http://www.arXiv.org/abs/math.RT/9912012>.

- [6] M. Dyer, *Hecke algebras and shellings of Bruhat intervals*, *Compositio Math.* **89** (1993), 91–115.
- [7] A. Knutson and T. Tao, *Apiary views of the Berenstein-Zelevinsky polytope, and Klyachko's saturation conjecture*, preprint, 1998.
- [8] I. G. Macdonald, *Symmetric Functions and Hall Polynomials*, 2d ed., Oxford Math. Monogr., Clarendon Press, Oxford, 1995.

Gleizer: Department of Mathematics, Northeastern University, Boston, Massachusetts 02115, USA;
ogleizer@neu.edu

Postnikov: Department of Mathematics, University of California, Berkeley, California 94720, USA;
apost@math.berkeley.edu; <http://www.math.berkeley.edu/~apost/>