

Hal



HONOURS AWARD FOR DESIGN EXCELLENCE

Hjelle

Hal



■ Helle

Hal



Hal



|| Helle

Hal

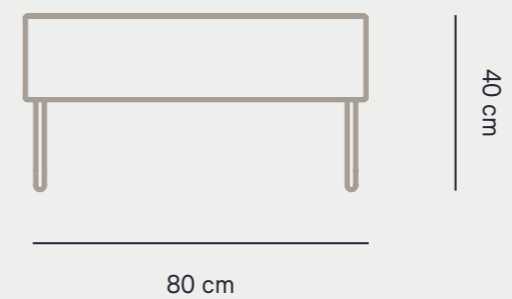
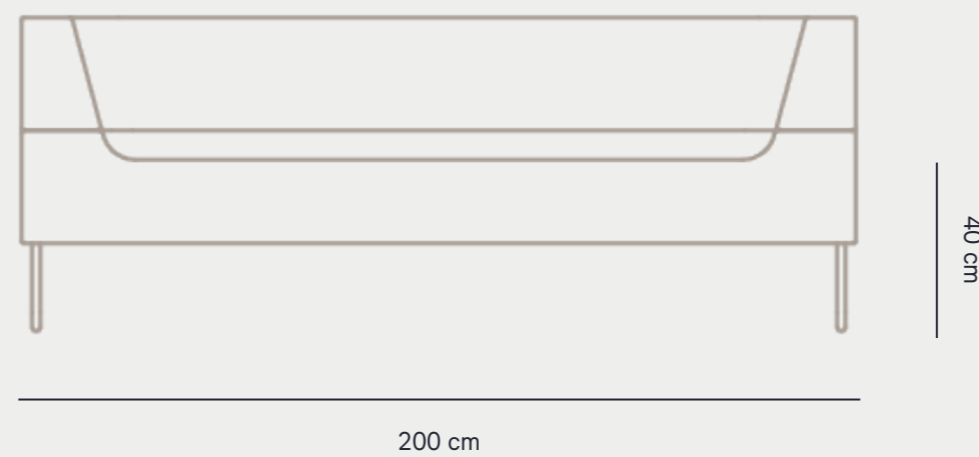
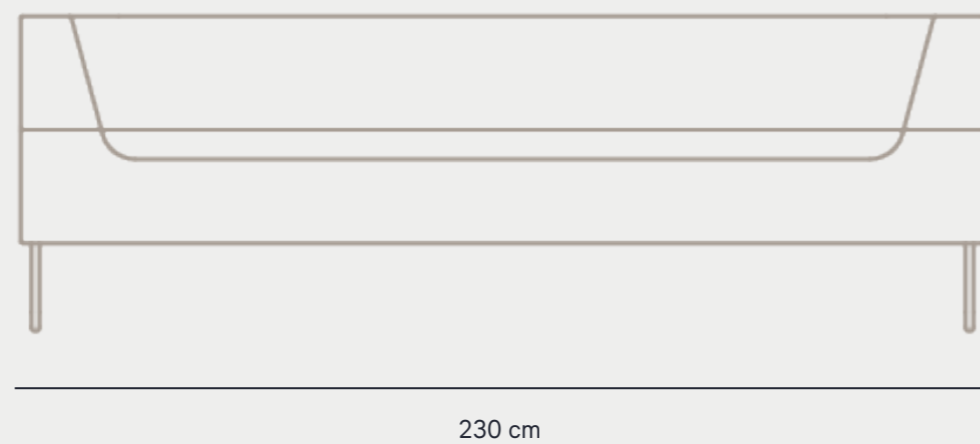
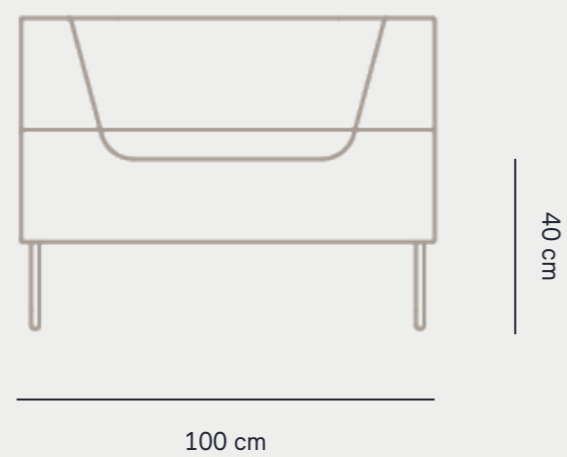
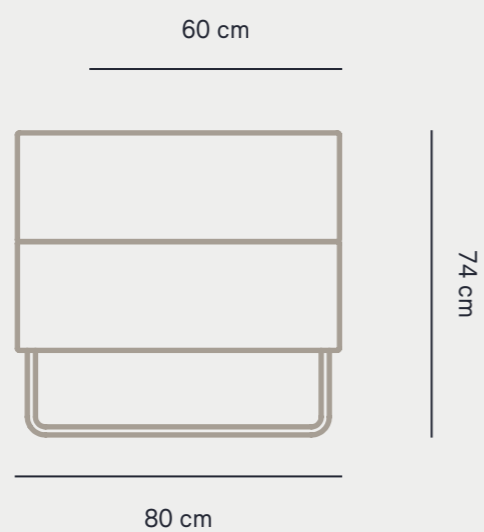



Norway Says

The young designer trio Norway Says managed to put Norway and Nordic forms back on the international design map shortly after they started their first collaboration in 1999. At first Norway Says was a design project, but in 2002 Torbjørn Anderssen, Andreas Engesvik and Espen Voll established Norway Says as a successful design group that achieved recognition and admiration worldwide for their Scandinavian aesthetics.

Norway Says won national and international prizes for their work, including Torsten & Wanja Søderberg Award, the Bruno Mathsson Award and the Wallpaper Award. The last mentioned was for Hjellev's sofa Ugo. After almost ten thriving years the three designers chose to end the adventure Norway Says in 2009.