

ASAE DISTINGUISHED LECTURE SERIES

TRACTOR DESIGN No. 25

This is not a peer-reviewed article.

R. Clay and P. Hemingway. 2001. Engineering Tractors for Higher Speeds. ASAE Distinguished Lecture No. 25, pp. 1-16.
Agricultural Equipment Technology Conference, 12-14 February 2001, Louisville, Kentucky USA.
Copyright 2001 American Society of Agricultural Engineers. ASAE Publication No. 913C0008.

ENGINEERING TRACTORS FOR HIGHER SPEEDS

Ray Clay and Paul Hemingway

**These lectures have been developed to provide
in-depth resource information for engineers
in the agricultural industry.**

Copyright © 2001 by the American Society of Agricultural Engineers
All Rights Reserved
Manufactured in the United States of America

This lecture may not be reproduced in whole or in part by any means
(with the exception of short quotes for the purpose of review)
without the permission of the publisher

For information, contact:

ASAE, 2950 Niles Rd., St. Joseph, MI 49085-9659 USA.
Phone 616.429.0300 FAX 616.429.3852 Internet: hq@asae.org

ASAE Publication Number 913C0008

The American Society of Agricultural Engineers is not responsible for statements and opinions
advanced in its meetings or printed in its publications.

They represent the views of the individual to whom they are credited
and are not binding on the Society as a whole.

ENGINEERING TRACTORS FOR HIGHER SPEEDS

Ray Clay

Chief Engineer

**JCB Landpower Ltd. Cheadle
Staffordshire, England**

Paul Hemingway

General Service Manager

**JCB Sales Ltd. Rocester
Staffordshire, England**

**For presentation at the Agricultural Equipment Technology Conference
Louisville, Kentucky
12-14 February 2001**

Published by

**ASAE — the Society for engineering in agricultural, food, and biological systems
2950 Niles Road, St. Joseph, MI 49085-9659 USA**

The Lecture Series has been developed by the Power and Machinery Division Tractor Committee (PM-47) of ASAE to provide in-depth design resource information for engineers in the agricultural industry. Topics shall be related to the power plant, power train, hydraulic system, and chassis components such as operator environment, tires, and electrical equipment for agricultural or industrial tractors or self-propelled agricultural equipment.

ASAE is grateful to Deere & Co. for sponsoring the ASAE Distinguished Lecture Series.

Table of Contents

INTRODUCTION.....	5
ENGINEERING FOR HIGHER SPEED	5
The market place today.....	5
30 kph (20 mph)	5
40 kph (25 mph)	5
50 kph (32 mph)	6
Above 50 kph (32 mph)	6
Fundamental principles.....	6
Vehicle ride.....	6
Vehicle handling	6
WHEEL AND TIRE TECHNOLOGY	6
Braking force	6
Cornering force.....	6
Accelerating force.....	6
STEERING	7
Slip angle	8
Center of pressure/pneumatic trail	8
Camber angle	8
Kingpin or swivel inclination	9
Caster angle	9
Steering response	10
SUSPENSION.....	10
Pitch Attenuation	10
Handling	11
BRAKING SYSTEMS	11
Legal requirements	
Tractor brakes.....	12
Trailer brakes	12
CASE STUDY — THE JCB FASTRAC	12
Suspension	12
Steering.....	14
Brakes.....	14
SUMMARY.....	15
REFERENCES	15
APPENDIX 1	16

ENGINEERING TRACTORS FOR HIGHER SPEEDS

This paper examines the market demand for tractors capable of higher than normal working speeds and discusses the evolution of such tractors in the market place over the past 20 years. The key engineering issues which have to be addressed in the construction of tractors of up to 80 kph (50 mph) speed capability are discussed in detail. Particular attention is paid to the areas of vehicle ride and handling, wheel and tire technology, steering, suspension and braking systems.

To illustrate that all necessary engineering requirements can be met in a vehicle that also develops comparable off road traction to that of a similar horsepower conventional tractor, the JCB Fastrac is discussed as a case study. Particular reference is made to the way in which the key vehicle systems above have been engineered into the vehicle.

INTRODUCTION

In the mid 1980s it was recognized within Western Europe that the shape of agriculture was changing such that the current configuration of farm tractor was found lacking by many users.

Farms had increased in size, often by the acquisition of off lying land and there was a trend towards greater use of agricultural contractors. All these factors led to increasing use of tractors on the road.

Previous research had attempted to quantify the proportion of work which large tractors (> 100 hp) spent in key operations. The key results are summarized in table 1.

It is not necessary to dissect the data too closely. The key factor is that European tractors above 100 hp today spend a large amount of time in transport related activity,

Table 1. Utilization of tractors > 100 hp in the UK

Operation	Percentage of Annual Use
Heavy tillage	15-20
Power take off	15-20
Transport related activity	60-70

This ASAE Distinguished Lecture Series was prepared and presented at the Agricultural Equipment Technology Conference, 12-14 February, 2001, Louisville, Kentucky, by Ray Clay and Paul Hemingway, JCB Group, Staffordshire, England. For additional information, correspondence may be directed to: Paul Hemingway, JCB World Parts Centre, Cheadle Road, Uttoxeter, Stoke on Trent, Staffs ST 14 7BS, United Kingdom, e-mail: <paul.hemingway@jcb.com>.

whether it be haulage of produce, moving from one part of a farm to another or carriage of implements such as crop sprayers or fertilizer spreaders.

Previous tractor designs had been largely restricted to optimizing in-field performance with no real development of technology to optimize performance at higher speeds.

It is recognized that this pattern of usage is not generally replicated in North America although there are areas and applications which do fit this pattern, such as hay baling contractors on the West Coast or operators hauling slurry from piggeries or dairies using tractor drawn tankers in the Midwest.

It was apparent that the needs of modern agriculture demanded more from the farm tractor than was currently offered. There was some evidence also that others were thinking this way. The Trantor transport tractor in the United Kingdom and the Mercedes Unimog in Germany were two examples of early transport tractors.

Up until the 1980s, fundamental tractor configuration and construction had changed little since the first tractors replaced the horse as a source of tractive power on the land. A normal operating speed of 30 kph (20 mph) had been in existence for many years.

In response to customer demand, manufacturers of conventional tractors had started to offer tractors with a maximum speed of 40 kph (25 mph) to those customers looking for increased transport performance. These tractors were physically identical to their 30 kph (20 mph) counterparts except in their gearing and brake systems.

European legislation relating to farm tractors generally reflects the fact that such machines historically were used on the land and spent minimal time on the road. Legislation reflected, and still does, the specific nature of local conditions. Differences in legislation exist between different countries within Europe.

The United States is even more extreme whereby farm tractors fall outside current road vehicle legislation requirements.

ENGINEERING FOR HIGHER SPEED THE MARKET PLACE TODAY

The general situation within the market place in terms of tractor speed is as follows:

30 kph (20 mph). Historically accepted as the normal speed for farm tractors. Vehicles normally feature rigid rear axles and trunnion mounted front axles. Full engineering standards are established for European Type Approval. (see Ref. No. 1).

40 kph (25 mph). Introduced in the 1980s in Europe as an option. Now the norm for tractors > 100 hp. Physically

similar to 30 kph machines except in gearing and brakes. European tractor legislation acknowledged their presence and was modified to incorporate an increased brake standard in 1997. (see Ref. No. 2).

50 kph (32 mph). Tractors incorporating higher ratio gearing and suspension of their front axles were first introduced in 1994. No European legislation governs the standards to which they are engineered although local legislation, such as German National Regulations for road going vehicles, does exist.

Above 50 kph (32 mph). Two manufacturers, at the time of writing, offer tractors in this classification.

The Mercedes Unimog is a utility type vehicle which has been in production since shortly after World War II. Its configuration restricts the maximum size of tire fitment to a 24 in. wheel. While the vehicle has good off road capability, it is not considered to have true tractor capability.

The JCB Fastrac, described later in this article, was introduced in 1991 as a true high speed tractor.

Both vehicles are engineered with suspension of both front and rear axles (full suspension) and have steering and braking systems engineered to truck standards.

FUNDAMENTAL PRINCIPLES

Having made the decision to engineer a high draft tractor to travel at higher speeds, it is critical for the designer to understand that the usage of the vehicle may vary dramatically from that of a conventional tractor.

In general, conventional tractors work off the road in isolation from large numbers of people. In contrast, fast tractors may, but will not always, spend the majority of time on the road in constant contact with other road users whether pedestrian or vehicular. The issue of responsibility is thus even more critical both in respect of other road users and the taxpayer.

In order to protect other road users, vehicles must be engineered to allow the driver to retain control under all conditions. Key safety related systems such as steering and brakes must reflect the speed capability of the vehicle and should give the driver a quality of ride and handling enabling him or her to retain full control of the vehicle.

The taxpayer, as always, is looking to minimize expenditure in such areas as medical treatment for those involved in road traffic incidents, but also in maintenance of road surfaces damaged by vehicles incorporating poorly designed or no suspension systems.

In discussing performance of high speed vehicles the terms ride and handling are commonly used. For clarity, definitions of these two terms are given below:

VEHICLE RIDE

Ride may be defined in terms of what the driver experiences as a result of sitting in the vehicle and being subjected to forces imposed on him by the vehicle when in motion.

VEHICLE HANDLING

Handling is the way that the vehicle itself responds to forces generated by its dynamic contact with the road surface during cornering, braking and acceleration.

WHEEL AND TIRE TECHNOLOGY

The prime function of a wheel and tire assembly is as a force generator. The three critical forces to be controlled in order of significance are:

BRAKING FORCE

Generated to reduce the speed of a vehicle by converting its kinetic energy to heat energy.

CORNERING FORCE

Used to oppose the lateral forces imposed on vehicle wheels in order to alter the trajectory of a vehicle.

ACCELERATING FORCE

Used to increase the speed of a vehicle.

These three forces have to be generated on both dry and wet surfaces which necessitates the tire be made of a high hysteresis compound generally incorporating natural rubber and wide longitudinal grooves for contact patch drainage.

A fourth inherent requirement for off road vehicles, and in particular tractors, is to generate traction forces. Tractor tires share with all off road tires the need to actually penetrate the surface of the ground over which they travel in order to mobilize soil shear strength to generate traction. This is achieved by supplementing conventional tire longitudinal grooving with cross grooving. Unfortunately, with this feature comes the potential of increased noise generation.

Tractor tire manufacturers have collectively developed a tire with about 40 individual angled cleats, 50 mm (2 in.) tall, majoring on tractive capability at the expense of noise and vibration.

All these forces must be generated efficiently with minimal heat generation, that is the tire must have a low rolling resistance so that maximum engine torque can be converted to tractive force.

The wheel and tire assembly cannot be considered to be a primary suspension medium. A primary suspension medium incorporates both a spring and a damper element.

Since Dunlop's development of the pneumatic tire, vehicle engineers have attempted to use tires as a secondary isolation medium supplementing primary suspension systems. From time to time vehicle designers from all industries have succumbed to the commercial temptation to dispense with the damper component of the primary suspension and rely on spring only, namely the tire.

Each time the result was blighted by the ensuing wheel shimmy, a detonated wheel vibration which rendered the vehicle unsteerable. The only industry able to condone this dynamic transgression for so long has been agriculture, and only because of its 30 kph (20 mph) speed limitation. These days are numbered as tractor engineers strive to engineer towards higher speeds.

Improved wheel and tire force variation control has enabled the speed restriction to be raised from 30 kph (20 mph) to 40 kph (25 mph) without problems, but the prospect of having the steering rendered inoperable at speeds above 40 kph (25 mph) is intolerable. In engineering the Fastrac range for maximum speeds of 50 kph to 80 kph ((32 mph to 50 mph) there was never any

consideration of a spring without a damping component. Attempts have been made to incorporate simplistic damping into the tire by carcass construction, but a vulcanized component is not ideal to serve as a heat dissipater. Modern damping requirements are very comprehensive. Different damping values are required for body and wheel frequencies and again each is different for bump and rebound. A mono-value damper is not adequate in today's environment.

A primary suspension is still a spring and damper. The function of a wheel and tire assembly is as a force generator, with albeit a component of secondary suspension supplementing the cab and seat suspension addressing minor road surface irregularities.

The first objective of good tire force generation is a constant vertical tire force at the ground surface, that is ground force variations must ideally be eliminated.

Total elimination is only achievable by fully active ride, that is the wheel is hydraulically lifted over a pre-viewed bump. High power consumption and cost constraints have precluded active ride as a commercial proposition, but force variations have been minimized by the adoption of low stiffness, long travel suspension. Tires must be homogeneously constructed with no heavy spots and uniform radial stiffness. Wheels also have to be well centered on their axles and uniformly round.

Good minimization of the 'first harmonic content' of the total force variation, that produced by one disturbance per wheel revolution, has proved sufficient for good ride quality up to 100 kph (62 mph).

Tire stiffness uniformity has been achieved by adopting tubeless Z rated car tire technology. Wheel bead seat uniformity has been achieved by adopting single piece welded rims, spigot location and flat faced wheel nuts. The wheel is thus accurately centered on a machined hub without any reliance on conical wheelnuts to achieve location.

An option to minimize force variation is countermatching, that is favorably positioning the tire on the rim so that any wheel force variation minimizes the tire force variation. This practice is commonplace on passenger cars, trucks and buses.

The second key to attaining good tire force generation is to maintain the vertical plane of the wheel at 90° to the ground.

The third key is to eliminate track width variations, that is the distance between the centers of the wheel treads on the same axle.

A beam type axle, suitably located and controlled, fulfills the last two requirements admirably.

STEERING

Historically tractors have incorporated pure mechanical steering, hydraulically assisted mechanical steering and full hydrostatic systems.

Modern tractors effectively all use hydrostatic steering. The characteristics of this are:

- Low steer effort.
- High steer torque.
- Limited or no feedback from the road wheels to the steering wheel.
- Limited or no self aligning ability.

- Loss of steering in the event of an engine or hydraulic failure.

As speed increases, the necessity to accurately control vehicle cornering behavior becomes absolute. In certain countries, such as Germany, regulations exist demanding a continuous mechanical link between the road wheels and the steering wheels to provide security in the event of engine or hydraulic failure.

At the time of writing, 50 kph tractors using hydrostatic steering are being marketed. It is felt, however, that above this speed truck style hydraulically assisted mechanical steering should be used. In comparison to hydrostatic steering this type of system in principle will offer:

- Higher steer effort at the hand wheel than hydrostatic systems.
- Lower levels of steer torque, as a consequence of the steering gears available in the market place having been engineered around truck applications.
- Positive feedback from the road wheels to the steering hand wheel.
- Self aligning ability and straight line stability without continuous correction.
- Integrity of steering control, albeit at higher effort in the event of engine or hydraulic failure.

Straight line stability is the ability of the vehicle to maintain a straight line without continuous steering correction. It is considered an absolute requirement for higher speed vehicles. Without it, travel requires intense concentration and continual corrections on the part of the driver.

This stability is provided by a 'self aligning torque' proportional to steering hand wheel angle.

If a single wheel is considered during cornering, the steer angle generates a lateral force normal to the direction of the wheel travel as shown in figure 1. This lateral force may be augmented by forces due to road camber or weight transfer effects. The lateral force is resisted by a reactive force at ground level known as the cornering force. Generally the cornering force grows as an equal and

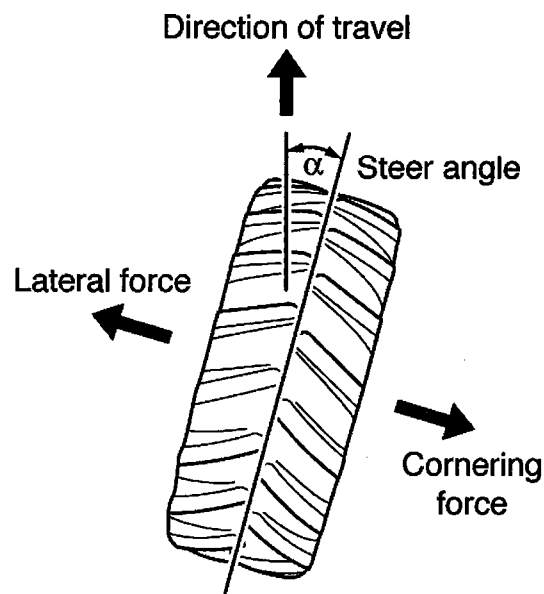

Figure 1—Generation of cornering force in a simple steered wheel.

opposite force to the lateral force until the tire's grip on the road becomes the limiting criteria.

SLIP ANGLE

Figure 2 shows a simple wheel subjected to a steer angle. In practice any pneumatic tired wheel subjected to a lateral force will through the flexibility of the sidewall allow the contact patch beneath the tire to distort sideways. As a consequence of this distortion the true path of motion will deviate away from the actual plane of the wheel rim. The difference between these two directions is known as the slip angle.

CENTER OF PRESSURE/PNEUMATIC TRAIL

As well as moving sideways due to lateral forces, the tire carcass will deform under rolling forces pushing the contact patch rearwards from that position which it occupies in the static position. The horizontal distance between the static center of the contact patch and the dynamic center of pressure is known as the pneumatic trail. The pneumatic trail for any given tire is a function of the tire construction, loading and inflation pressure.

In a complete vehicle, the situation is rather more complex. At the initiation of steering, the front wheels of the vehicle turn through different steer angles defined by the Ackermann geometry of the front axle. A front axle cornering force is generated which moves the front axle in the direction of the turn. At this stage the rear wheels are still traveling straight ahead.

The movement of the front axle pulls the front of the vehicle chassis in the direction of the corner and the chassis in turn places a torque on the rear axle forcing the wheels to follow the general direction of the corner. The rear axle wheels in turn generate their own cornering force. The rear axle slip angle will not generally be the same as that of the front axle.

The balance of the cornering forces generated by the front and rear axles determines whether the vehicle has an under steer or over steer characteristic.

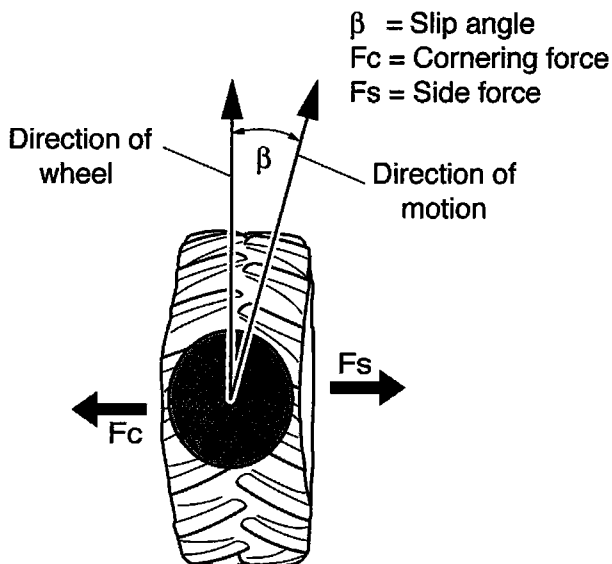

Figure 2-Generation of slip angle due to side force.

Under steer is evident when front axle slip angles are greater than those of the rear axle. This is characterized by the driver having to apply more steer angle to maintain trajectory on a bend of fixed radius while accelerating. On a given bend at a given radius vehicles with under steer characteristics tend to steer out of the bend thus reducing centrifugal and ground reaction forces and slip angles.

Conversely, if over steer is evident, rear axle slip angles are greater than front axle and during a similar test the driver has to reduce the steer angle to maintain the bend radius. On a given bend at a given radius, vehicles with over steer will tend to steer towards the bend thus decreasing their turn radii and increasing centrifugal forces. This in turn develops greater ground reaction forces and increased slip angles. The characteristic can rapidly become unstable.

Due to the above, most drivers will find it more comfortable to control a vehicle with understeer rather than one with oversteer. It is generally considered that understeer is desirable in all vehicles except those where the drivers actively seek excitement.

Steering characteristics cannot be isolated to the steering system alone because vehicle dynamics can have a significant effect on steer behavior. This is discussed further under suspension.

It is important to understand the relevant parts which wheel control geometry play in vehicle handling.

CAMBER ANGLE

This is defined as the angle of the vertical plane of the road wheel with the ground. (fig.3). When the top of the wheel leans outwards with respect to the body the camber is said to be positive and vice versa. Positive camber angle effectively moves the contact patch inboard towards the projected ground kingpin point. The wheel, if freed to rotate off the vehicle at this angle of inclination, would prescribe an arc away from the vehicle. Its partner on the other side of the vehicle would move off in the opposite

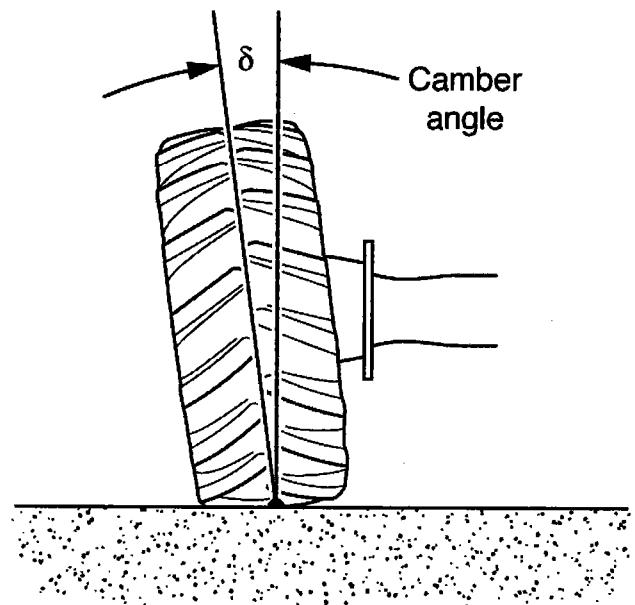

Figure 3-Camber angle.

direction and so the wheels in motion set up equal and opposite forces tending to centralize the steering.

When both front wheels are fitted with positive camber, during cornering the inside wheel leans into the vehicle becoming more upright and generating a smaller slip angle albeit with lower imposed load due to weight transfer. The outside wheel by comparison leans further out with greater imposed mass and generates a larger slip angle. On average the front axle will produce greater slip angles than the rear axle with upright wheels and the vehicle should have an under steer characteristic.

Excessive camber angle however, reduces the tire's ability to generate cornering force and results in increased tire wear.

KINGPIN OR SWIVEL INCLINATION

This is the inward tilt of the swivel or kingpin in relation to the ground in front elevation. (fig. 4). The projection of this axis onto the ground is known as the pivot center and the dimension from this point to the center of the tire contact patch is known as the ground offset.

As the wheel rotates around the axis of the swivel it prescribes an arc of radius equivalent to the offset. It can be seen that if the offset is zero then the tire will be forced to scrub on the spot inducing high wear. However, if the

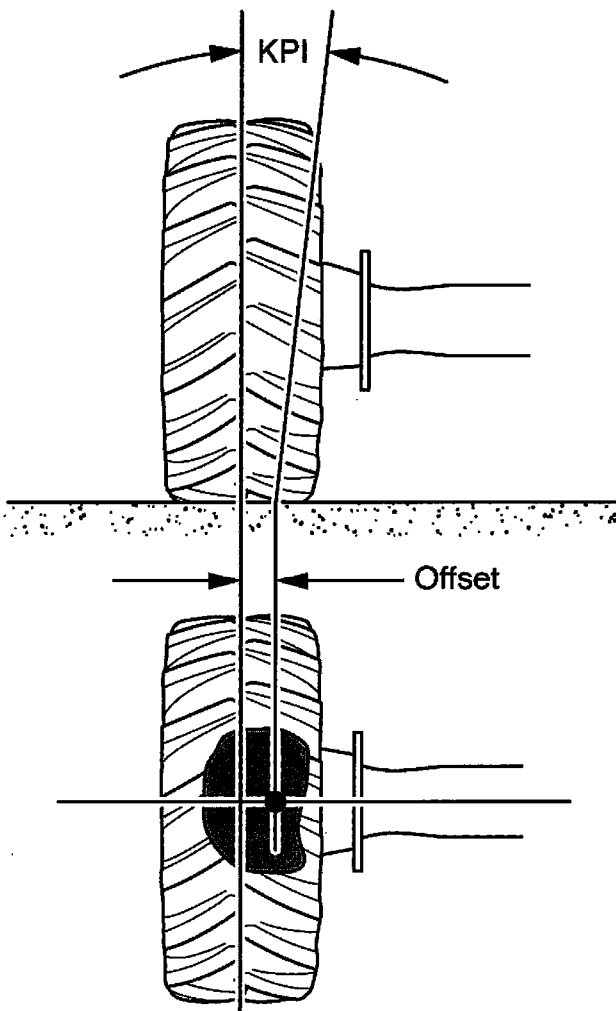

Figure 4—King pin inclination (KPI).

offset is too great then the assembly becomes prone to large forces being transmitted up the steering mechanism in the event of an obstacle being hit by either wheel.

As the kingpins rotate, the kingpin inclination forces the body of the vehicle to be raised in relation to the ground. When the steering hand wheel turning torque is removed, the vertical body force restores the road wheel to zero angle. The inclination plays a critical role in the self aligning characteristic of the steering. Excessive kingpin inclinations provide very strong self centering which may give a strong non-centering force when going backwards.

A trusted design criterion is to keep the kingpin 'projected ground contact point' within the second inside quarter of the contact patch. The distance of this point from the centerline of the contact patch shall be no greater than 1/4 of the contact patch width. The kingpin inclination has to be viewed in combination with the camber angle for any particular installation.

CASTER ANGLE

This is the angle of the kingpin to the ground in side elevation (fig. 5). As a consequence of this angle the contact patch of the tire lies either behind a projection of this axis on the ground (positive caster) or in front (negative caster). When a steer angle is induced, the contact patch of the tire is swung out of line with the direction of travel imposing a centralizing force on the wheel. The magnitude of the self centering force increases

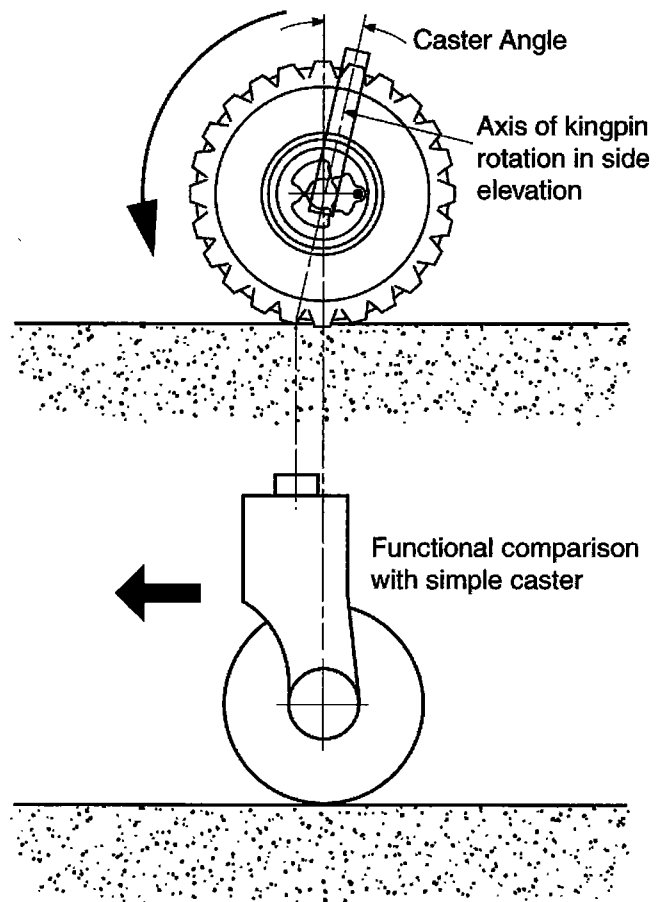

Figure 5—Caster angle.

with both traction and speed and is of particular significance in off road vehicles.

The merits of a particular combination of angles is the domain of the suspension development engineer and durability testing, but 1° of camber angle, 6° kingpin inclination and 3° castor angle is a safe place from which to start.

Having engineered the vehicle, the characteristics of the steering must be validated in tests during cornering as well as in a straight line.

STEERING RESPONSE

The response of the vehicle to input from the steering wheel is critical to vehicle feel and behavior. This is quantified by mounting an accelerometer laterally on the vehicle and measuring increase in cornering acceleration against time (fig. 6).

If the time is too short the vehicle will be twitchy to operate and require continuous correction to maintain it in a straight line. Conversely if the time is too long, the vehicle will be sluggish to respond and may create real problems for the driver.

In the extreme case, if the driver first steers right and then rapidly left, the driver may be turning the wheel left while, or even before, the vehicle has started to move right. The steering wheel thus becomes out of phase with the motion of the road wheels and in attempting to correct this the steering column can appear to have elastic properties.

In practice the target response time to develop maximum cornering force is between 0.6 and 0.8 s.

SUSPENSION

In general terms the benefits which suspension has the potential to give vehicles can be summarized as follows:

- Greater ride comfort and isolation from Whole Body Vibration, both in the field and on the road.
- Better control of the vehicle by the driver through minimized ground force variations of the wheels.
- Better handling characteristics of the vehicle for safer use on the road.
- Increased field traction through constant ground force at the wheels.
- Lower ground compaction through reduced variations in ground force, the load being exerted by the tire onto the soil at any point in time.
- Potential for greater travel speeds made possible by minimized body accelerations.

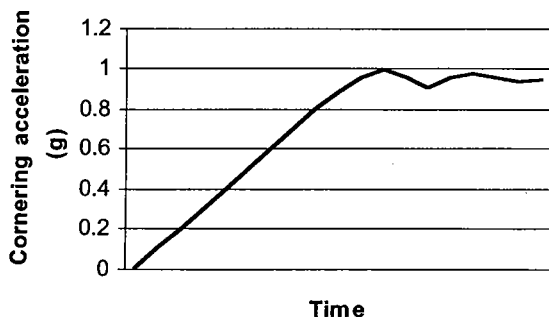

Figure 6—Cornering acceleration generation against time.

In order to address all ride and handling characteristics of a fully suspended vehicle, the freedom of movement of the major components of the vehicle must be recognized. These are shown in table 2.

In practice these motions will not occur in isolation. For example, under severe cornering, body roll and yaw will be experienced simultaneously. If the brakes are applied in the corner, the vehicle will also experience pitch as weight transfers from the rear to the front of the vehicle as a result of the braking force.

The requirements for optimal suspension on a high speed, draft tractor make specific demands on the engineer.

- For optimum traction, tires must be kept such that the force that they exert on the ground surface remains constant, however rough the surface may be.
- Tractors experience large variation in loading either within the wheel base as in a loaded truck or cantilevered at the rear or front of the vehicle when carrying mounted implements.
- During high power, high draft operations, power is transmitted through the drive wheels using low speed and high torque. This torque has to be reacted through the axle location mechanism with no vertical component reaction.
- Travel over rough ground demands significant axle travel to avoid generating high ground forces when addressing bumps.
- Predictable and controllable cornering characteristics are most easily achieved with equal tire sizes on both front and rear axles.

PITCH ATTENUATION

The frequencies of the front and rear suspension are matched to attenuate fore and aft pitch. To achieve this, the frequency of the rear suspension must be higher than the front. If the front axle hits a bump, the axle and suspension together form a spring mass system setting up a sinusoidal vibration where the frequency is given by:

$$\text{Frequency} = c\sqrt{\text{Stiffness/Load}} \quad (1)$$

Given a working speed, after time, *t*, the rear axle hits the same bump and generates its own vibration. To effectively attenuate pitch, the vibration of the rear axle suspension should have regained phase with the front axle after one cycle. This is illustrated graphically in figure 7. To achieve synchronization of the axle movements, frequencies must be chosen for the axles in relation to a design speed for the vehicle. The design speed dictates the lag between the disturbances created on each respective axle.

Table 2. Vehicle component degrees of freedom

Motion	Front Axle	Rear Axle	Body
Linear	Fore/aft	Fore/aft	Shunt
	Side/side	Side/side	Shake
	Up/down	Up/down	Bounce
Angular	Roll	Roll	Roll
	Yaw	Yaw	Yaw
	Nod	Nod	Pitch

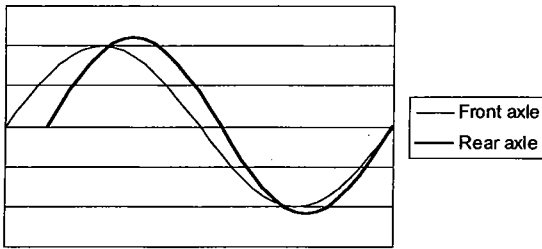

Figure 7—Graph of relative suspension frequencies of front and rear axle suspensions to attenuate pitch.

HANDLING

Generally the features that make for good ride are those that make for good traction, but it is necessary for a vehicle traveling in excess of 40 kph (25 mph) to have good handling.

Handling is the vehicle's ability to respond to forces from cornering, braking, acceleration or combinations of any two of these.

The traditional maneuver used by vehicle dynamists in appraising basic handling is the ISO lane change maneuver. This is born out of a real life situation. A child steps off the sidewalk into the path of an approaching vehicle. The vehicle is required to swerve to the opposite side of the road to avoid the child, only to be confronted by an oncoming vehicle. It is then required to swerve back to the original side of the road without encroaching on the sidewalk. The vehicle must be capable of undertaking this maneuver at speeds of 50 kph (30 mph) without fishtailing. Anything above 40 kph (25 mph) requires 4 springs, 4 dampers and certainly no front axle pivot trunnion. A front axle trunnion effectively converts the vehicle into a three wheeler with the single wheel at the front; a dynamic travesty.

The second maneuver is a steady state acceleration as laid down in ISO 4138. Here the vehicle embarks on a constant slow speed circular trajectory. With the hand wheel angle maintained constant, the vehicle is progressively accelerated and its trajectory monitored. The trajectory radius should increase at a constant rate. This condition is known as progressive understeer. If the trajectory radius reduces, then it is known as a condition of oversteer, a potentially unstable condition for the average driver.

The third maneuver is the J turn, not covered by an ISO standard, but a General Motors test, similar to a steady state test but with a dynamic content. The vehicle approaches a prescribed circle at a tangent at a constant speed. The vehicle is changed from a straight-line trajectory to a circular trajectory at progressively increased speeds. The build up of front and rear cornering forces with time is monitored. Dynamic understeer is to be maintained until limit adhesion.

These three traditional maneuvers have been supplemented by further measures such as slalom, side wind, stepped input and most recent of all the infamous 'moose' test.

All these maneuvers are designed to ensure that any vehicle sharing the highway with the rest of vehicular society has a minimum degree of dynamic prowess.

Unfortunately the parameters that make for good handling often detract from ride quality and traction.

The art of the vehicle dynamist is to strike an effective balance between ride and handling; maintaining vehicular functionality while protecting its occupants from excessive G shocks.

BRAKING SYSTEMS

Fundamentally brakes serve the function of reducing vehicle kinetic energy by conversion into heat energy. As a function of the square of vehicle speed, kinetic energy increases rapidly as shown in figure 8.

It can be seen that to a close approximation, vehicles traveling at 80 kph (50 mph) are required to dissipate approximately seven times the energy of those traveling at 30 kph.

This situation is exacerbated by the legal requirement for faster moving vehicles to decelerate at higher rates. 30 kph (20 mph) tractors have historically been required to have braking systems capable of deceleration at $2.5 \text{ m}\cdot\text{s}^{-2}$ ($8 \text{ ft}\cdot\text{s}^{-2}$). In comparison truck standards call for approximately $5.0 \text{ m}\cdot\text{s}^{-2}$ ($16 \text{ ft}\cdot\text{s}^{-2}$).

It can be seen that the combination of higher energy level and more rapid deceleration requires brake systems with excellent heat dissipation characteristics.

Conventional tractors have normally relied on either dry or oil immersed disc brakes incorporated within the tractor rear axle. The oil used is common with that used for axle lubrication and frequently both gearbox lubrication and external hydraulic oil supply to implements. Contamination of this oil with brake lining debris can lead to serious functional problems within the tractor hydraulic or transmission systems. Breakdown of oil lubrication properties can also occur if the oil is subjected to high temperatures leading to impaired durability of componentry.

The heavily biased weight distribution and large rear tires of these machines have enabled such tractors to generate sufficient braking effort from their rear wheels alone and typically such machines have no front brakes fitted.

The move to 40 kph (25 mph) in Europe has coincided with the almost universal acceptance of front wheel assist driven axles. This has given manufacturers the opportunity to either engage front axle drive while braking or to incorporate some form of disc brake onto the front axle drive shaft to assist the braking effort. This technology has been carried into the 50 kph (32 mph) models now available.

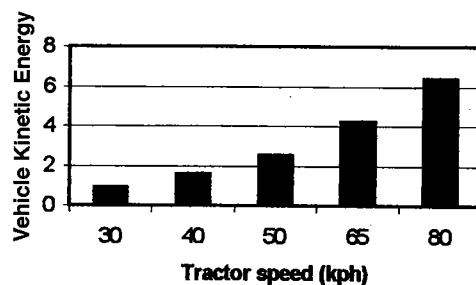

Figure 8—Relative vehicle kinetic energy v. forward speed (kph).

Beyond 50 kph (32 mph) it is felt desirable that the brake elements of high speed tractors are external to the axle housing and packaging of the componentry favors the use of disc/caliper mechanisms. Air actuation of the brake mechanism leads to improved modulation of operation and also the opportunity to use a number of proprietary control components developed for the truck industry.

In practice, feed to brake calipers will require conversion of air pressure to oil pressure and this is achieved through readily available air:hydraulic actuators. During this conversion air pressure of typically 8 bar (120 psi) may be converted to hydraulic pressure of 160 bar (2400 psi).

LEGAL REQUIREMENTS

TRACTOR BRAKES

If adherence to truck brake standards is sought, split circuit brakes must be engineered. In other words, the circuitry for two of the wheels must be discreet from that for the other two, such that in the event of a failure at least partial braking remains available. The split may be either fore/aft or diagonal.

Rapid deceleration from higher speeds dictates significant weight transfer from the rear of the vehicle to the front. Brake capacity must reflect this, typically with larger discs and calipers being fitted to the front axle.

A significant feature of brake testing for trucks is for brake fade. This test is made to test the capability of the brake system under repeat applications which would be encountered in practice on a long incline. The EU truck brake test standard (see Ref. No. 3) calls for 20 successive brake applications at 1 minute intervals from 80% to 20% of the design speed, with the brake pressure reduced to create a deceleration of $3 \text{ m}\cdot\text{s}^{-2}$. At the end of these runs a final run is made as quickly as possible at full pressure and it must be demonstrated that there is no significant fall off in brake performance.

There is no question that the rapid heat dissipation from outboard external brakes offers an easier route to meet the demands of this type of test than if internal brakes are used.

Truck brake standards also call for significant levels of stored energy so that in the event of an engine failure, sufficient braking capability is held on board the vehicle to enable it to be brought to a controlled standstill.

TRAILER BRAKES

In order to provide controlled braking when tractors are used in combination with trailers, the braking characteristics of the trailers must be matched to that of the tractor. In the event that the tractor brakes are engineered to truck standards, few problems exist in that trailer brake equipment is readily available to meet the same standard.

Higher speeds dictate that air actuation is used for trailer brakes, the industry norm being two line operation. A supply line charges the brake system on the trailer while the control line only provides pressure when the tractor brakes are operated. In the event of the trailer becoming detached from the tractor, the supply line is cut and the trailer brakes automatically apply hopefully bringing the trailer to a safe stop.

The trailer brakes must be operated by the same control that operates the tractor service brakes. The trailer control

valve will normally provide a degree of predominance expressed in terms of air pressure, i.e. 0.5 bar (7 psi). When the brakes are applied and pressure starts to build, predominance defines the pressure which builds up in the trailer circuit before the build starts in the tractor brake pressure. This ensures that the trailer tends to keep the combination straight and the coupling tight during the brake operation.

CASE STUDY — THE JCB FASTRAC

The principles outlined in the first part of this article discuss those areas of vehicle engineering which have to be addressed if tractors are to be engineered at higher speeds. There follows a description of one approach to the fulfillment of these requirements which is not intended to be dogmatic in any way. The study proves however, that it is feasible to address all the necessary engineering criteria for such a vehicle in such a way that is acceptable to the market place.

SUSPENSION

The configuration of the suspension shown in figures 9 and 10 was engineered to address all the requirements set out above.

The axles are located relative to the chassis by parallel suspension links. This ensures that drive torque variations do not manifest themselves as ground force variations. The torque from the transmission is reacted by the links, exerting equal and opposite forces in the arms dependent on the direction of travel. Torque reaction thus produces no variation in tire ground contact force which helps maintain traction at an optimal level. The length of the links is maximized to allow maximum axle travel without incurring large rotation angles at the link end joints. The front axle suspension incorporates progressive spring rates using coil springs, polyurethane and rubber springs in combination to stiffen the suspension as greater loads are applied. Primary suspension rate is approximately 10 kg/mm. In series with the tire stiffness of a typical tractor front tire of 80 kg/mm, overall rate is calculated from:

$$\frac{1}{R_T} = \frac{1}{R_1} + \frac{1}{R_2} \quad (2)$$

giving in this instance a composite rate of approximately 8 kg/mm.

Lateral location of the front axle is provided by a Panhard rod (fig. 9) which is a pin jointed component connected to the chassis side rail on one side of the vehicle and the axle casing on the other side. The loads carried by this link are large in that it provides a reactive member to the forces exerted by the vehicle steering link.

The low stiffness of the suspension coupled with large tires means that if uncontrolled, the vehicle would roll heavily in cornering. As well as making the vehicle difficult to control physically because of the inertia on the driver, the handling of the vehicle would be extremely poor due to lack of control of the cornering forces proportionately generated by inside and outside wheels. This is addressed by the fitment of a torsional anti roll bar

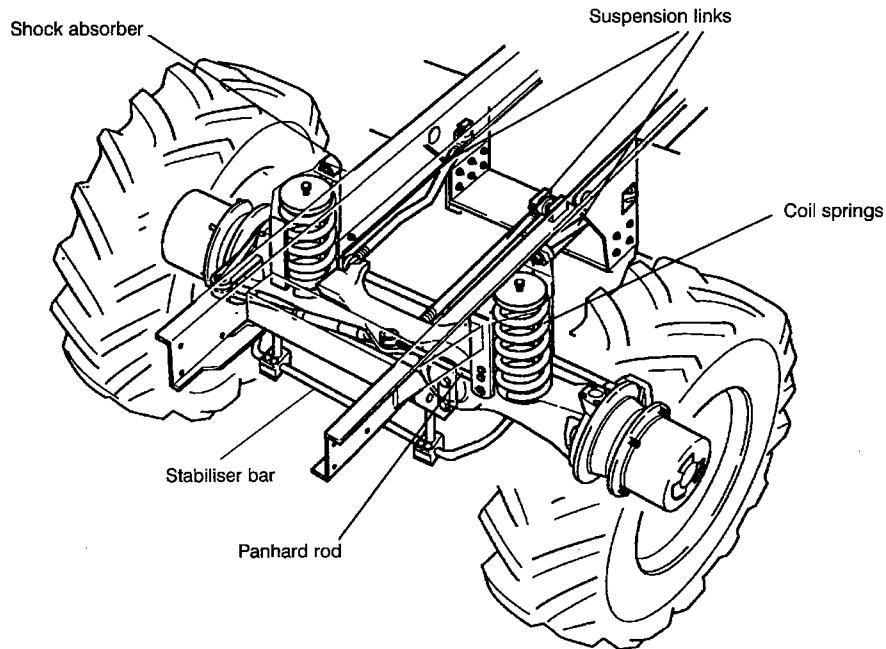

Figure 9—JCB Fastrac front suspension layout.

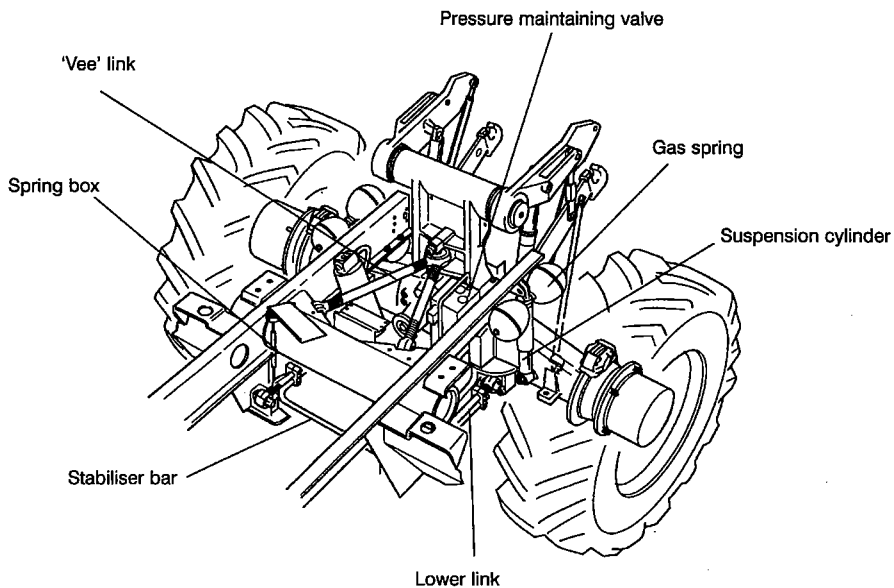

Figure 10—JCB Fastrac rear suspension layout.

which is bushed onto the chassis at its mid section and onto the axle at its extremities (fig. 9).

Controlled damping is provided by conventional twin tube shock absorbers which are tuned to match the characteristics of the primary suspension.

The rear suspension (fig. 10) incorporates a similar concept of axle location to that of the front axle. Again the axle is located by parallel links, although in this case the upper two links are joined as a V link. The V link takes load from the center of the rear axle to each side of a chassis cross member providing lateral location.

To assist packaging and to help maintain a level attitude of the vehicle in the fore and aft plane, rear axle suspension is provided by a hydropneumatic system. Oil is fed from a dedicated engine mounted pump to a pressure maintenance

valve. Links connect ride height valves on each side of the chassis to the forward end of each lower control link. The ride height valves control the flow of oil into and out of a pair of single acting hydraulic cylinders supporting the chassis above the axle. The pressure of the oil in the cylinders is balanced by a pair of nitrogen charged gas springs mounted directly into the head of each cylinder. Damping elements are engineered into the necks of the gas springs providing the function of a conventional coil spring and damper arrangement within a single component.

Under normal loading, the system pressure lifts the chassis to a height above the axle controlled by the length of the suspension sensing links. If a load is placed directly onto the vehicle chassis, the added load increases the pressure in the cylinders. Oil flows out of the cylinders and

into the gas springs, allowing the chassis to sit down on the axle. This movement is sensed by the links and the ride height valves open allowing more oil into the cylinders until the chassis reaches its former height. Conversely, relieving the chassis of weight causes the chassis to rise and the height corrector valves open allowing oil back into the hydraulic tank.

A key feature of the rear suspension is that it has no interaction with the implement three point linkage on the machine. The three point linkage is fully mounted onto the axle and so is able to use the wheel as a reference from which to measure height or depth. Movements in suspension travel do not affect the work of linkage mounted implements in any way. This particular feature is covered by patent.

Implements such as deck mounted crop sprayers are ideally suited for use with this type of suspension. If a 2000 litre (600 gal) sprayer is deck mounted and subsequently empties during work some 2000 kg (4500 lb) load reduction is felt by the vehicle. The self levelling capability of this suspension allows the height of the deck to be continuously adjusted to maintain constant height of the boom above the crop, which is of course ideal.

Again, a torsional anti roll bar is provided to give good roll control. The front and rear suspensions are tuned so as to give predictable, controlled understeer behavior when cornering at speed.

STEERING

Fastracs engineered for speeds greater than 50 kph (32 mph) are fitted with power assisted mechanical steering as shown on figure 11. The steering gear itself is similar in concept to that fitted to trucks. Necessary modifications which have been made for tractor application are increased torque capacity and an increased casing bolt pattern connecting the steer gear to the chassis to ensure secure location.

The steering gear (fig. 12) is a recirculating ball 'concentric worm' type driving a pinion sector on the output shaft. This arrangement provides mechanical contact between the steering wheel and the road wheels.

The outer component of the worm gear is also designed as a double acting piston for hydraulic power assistance. Hydraulic flow, fed by an independent engine mounted pump, is flow and pressure regulated to give a constant steering effort. Flow is diverted to the correct side of the piston by ports, opened by the relative movement between the actuating shaft (1) and rotary valve (2). Oil retained in

3000 Series Steering System

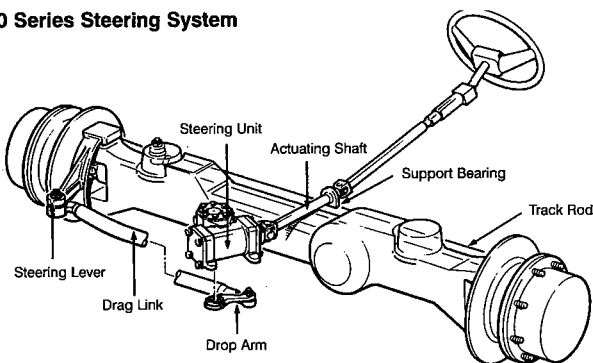

Figure 11—JCB Fastrac steering system.

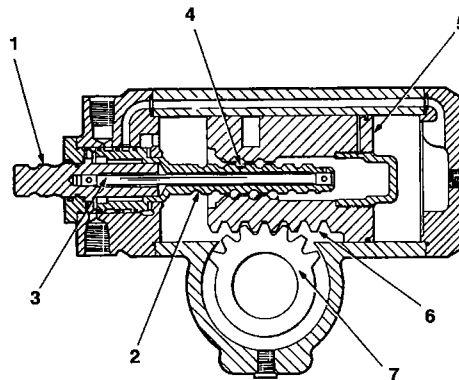

Figure 12—JCB Fastrac steering gear.

the steering gear also helps dampen out road shocks fed back through the mechanical system.

The torque generated by the output shaft is translated by the drop arm into thrust along the drag link which rotates the right hand steer swivel which in turn is connected to the left hand swivel using a track rod. The drag link thrust is reacted by the front suspension Panhard Rod back from the axle to the chassis (fig. 9).

BRAKES

The Fastrac is fitted with an air over hydraulic service brake system using proprietary truck componentry. A schematic circuit diagram is shown in figure 13.

An engine mounted compressor (B) supplied from the clean side of the engine air cleaner (A) is fed to the unloader valve (C). An air drier may be fitted at this point to remove humidity and minimize valve corrosion. A circuit protection valve (F) splits out the feeds to:

- Front axle brakes
- Rear axle brakes
- Park/trailer brakes
- Ancillaries (clutch, air seat)

The front and rear axle lines have independent tanks (G1, G2) to provide sufficient energy to meet brake needs in the event of a dead engine. Lines are then led to the footbrake valve mounted on the cab bulkhead which in turn feeds independent air/hydraulic actuators (K1, K2). Feeds of brake fluid are then taken to the front and rear calipers (L, M).

The feeds from the footbrake valve also provide signals to the trailer brake valve allowing pressure to the trailer control line (TC). The trailer supply line (TS) is continually fed with air allowing the trailer brake system to charge and release the trailer brakes.

The park brake valve (R) releases air from a spring brake acting on a disc mounted on the transmission output shaft. Releasing the valve charges a brake piston releasing the clamp load. The park brake is thus fail safe.

For use at lower speed, other equipment may be fitted. The inverse relay valve (W) is used to provide single line air supply to operate older German trailers. The hydraulic trailer brake valve (X) is very similar to that fitted to conventional tractors using a signal from the footbrake circuit to allow supply of tractor hydraulic oil to feed single line hydraulic brakes commonly used throughout Europe.

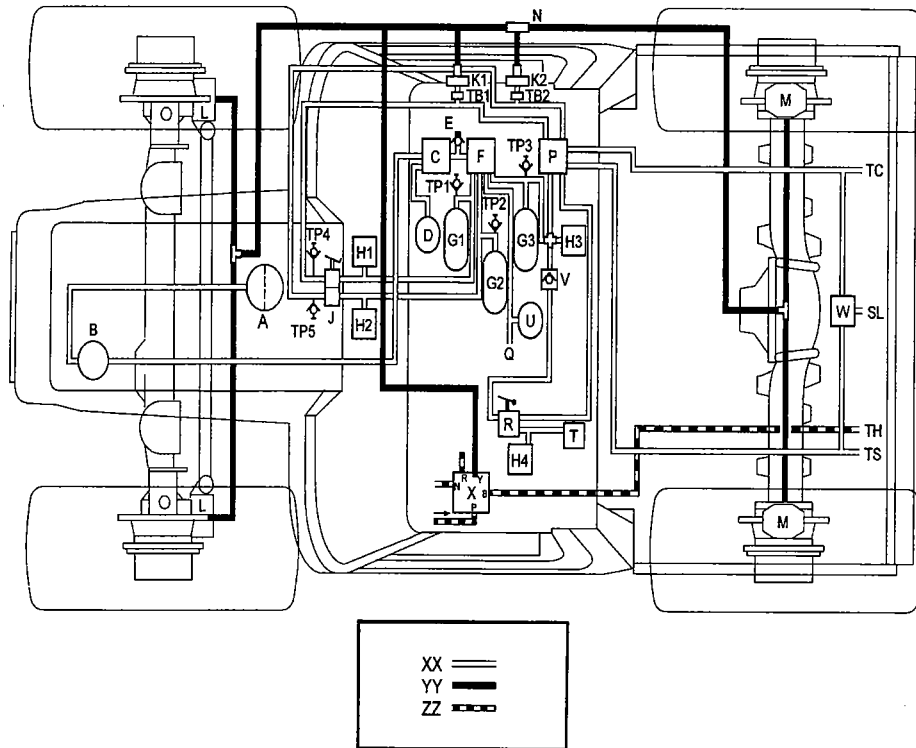

Figure 13—JCB Fastrac Air-hydraulic brake system.

SUMMARY

In summary, the challenges which face designers of higher speed agricultural tractors can be seen to be very similar to those previously faced by automobile and truck designers over the years. The addition of low stiffness suspension onto agricultural tractors has the potential to not only improve the ride and handling of the vehicle but also to increase field traction through maintenance of constant ground force exerted by the tire.

The case study of the JCB Fastrac vehicle and its' success after 10 years in the market demonstrates that a vehicle can be created combining the attributes of higher speed up to 80 kph (50 mph), excellent ride and secure handling on the road, with high traction in the field.

Changes in the agricultural industry, particularly in Europe have shown demand for tractors with higher speed capabilities and this has been acknowledged by all major tractor manufacturers now offering tractors with front axle suspension at the 50 kph (32 mph) level. It is suggested that above this speed the suspension of all four wheels is necessary.

REFERENCES

1. **74/150/EEC** Council Directive of 4 March 1974 on the approximation of the laws of the Member States relating to the type-approval of wheeled agricultural and forestry tractors
Note: This directive has been subsequently amended by:
79/694/EEC
82/890/EEC
88/297/EEC
2000/2/EEC
and ultimately replaced by:
2. **97/54/EC** Directive of the European Parliament and of the Council of 23 September 1997 amending, as regards the maximum design speed of wheeled agricultural and forestry tractors, Council Directives 74/150/EEC, 74/151/EEC, 74/152/EEC, 74/356/EEC, 74/347/EEC, 75/321/EEC, 75/322/EEC, 76/432/EEC, 76/763/EEC, 77/311/EEC, 77/537/EEC, 78/764/EEC, 78/933/EEC, 79/532/EEC, 79/533/EEC, 80/720/EEC, 86/297/EEC, 86/415/EEC, 89/173/EEC.
3. **71/320/EEC** – Council Directive of 26 July 1971 on the approximation of the laws of the Member States relating to the braking devices of certain categories of motor vehicles and of their trailers.
Note: This directive has been subsequently amended by:
74/132/EEC
75/524/EEC
79/489/EEC
85/647/EEC
88/194/EEC
91/422/EEC
and ultimately replaced by:
98/12/EEC Council Directive of 27 January 1998 adapting to technical progress Council Directive 71/320/EEC on the approximation of the laws of the Member States relating to the braking devices of certain categories of motor vehicles and their trailers.

APPENDIX 1
ISO AUTOMOTIVE STANDARDS APPLICABLE TO THE
CONTENT OF THIS ARTICLE

	ISO Number
Road Vehicles Sensitivity to Lateral Wind — Part 1: Open-Loop Test Method Using Wind Generator Input, 1st Ed.	12021-1:1996
Passenger Cars Steady-State Circular Driving Behavior — Open-Loop Test Procedure, 2nd Ed.	4138:1996
Road Vehicles Lateral Transient Response Test Methods 1st Ed.	7401:1988
Passenger Cars Braking in a Turn — Open-Loop Test Procedure 2nd Ed.	7975:1996
Passenger Cars Power-Off Reactions of a Vehicle in a Turn Open-Loop Test Method First Editions	9816:1993
Road Vehicles Test Procedure for a Severe Lane- Change Maneuver 1st Ed. (Erratum- 1978)	3888-1:1999
Road Vehicles Transient Open-Loop Response Test Method with One Period of Sinusoidal Input, 1st Ed.	TR8725:1988
Road Vehicles Transient Open-Loop Response Test Method with Pseudo-Random Steering Input, 1st Ed.	TR8726:1988