

ASAE DISTINGUISHED LECTURE SERIES

TRACTOR DESIGN No. 24

[This is not a peer-reviewed article.](#)

L. Harms and W. Guse. 2000. Electrical/Hydraulic Proportional Control Valves and Their Use in Agriculture Powershift Transmissions. ASAE Distinguished Lecture No. 24, pp. 1-9. Agricultural Equipment Technology Conference, 23-25 February 2000, Kansas City, Missouri USA. Copyright 2000 American Society of Agricultural Engineers. ASAE Publication No. 913C0500.

ELECTRIC/HYDRAULIC PROPORTIONAL CONTROL VALVES AND THEIR USE IN AGRICULTURE POWERSHIFT TRANSMISSIONS

Louis Harms and William Guse

**These lectures have been developed to provide
in-depth resource information for engineers
in the agricultural industry.**

Copyright © 2000 by the American Society of Agricultural Engineers
All Rights Reserved
Manufactured in the United States of America

This lecture may not be reproduced in whole or in part by any means
(with the exception of short quotes for the purpose of review)
without the permission of the publisher

For information, contact:
ASAE, 2950 Niles Rd., St. Joseph, MI 49085-9659 USA.
Phone 616.429.0300 FAX 616.429.3852 Internet: hq@asae.org

ASAE Publication Number 913C0500

The American Society of Agricultural Engineers is not responsible for statements and opinions
advanced in its meetings or printed in its publications.
They represent the views of the individual to whom they are credited
and are not binding on the Society as a whole.

ELECTRIC/HYDRAULIC PROPORTIONAL CONTROL VALVES AND THEIR USE IN AGRICULTURE POWERSHIFT TRANSMISSIONS

Louis Harms

**International Sales Manager
Fluid Power Systems Division of Parker Hannifin Corporation**

William Guse

**Engineering Manager
Fluid Power Systems Division of Parker Hannifin Corporation**

**For presentation at the Agricultural Equipment Technology Conference
Kansas City, Missouri
23-25 February 2000**

**Published by
ASAE — the Society for engineering in agricultural, food, and biological systems
2950 Niles Road, St. Joseph, MI 49085-9659 USA**

The Lecture Series has been developed by the Power and Machinery Division Tractor Committee (PM-47) of ASAE to provide in-depth design resource information for engineers in the agricultural industry. Topics shall be related to the power plant, power train, hydraulic system, and chassis components such as operator environment, tires, and electrical equipment for agricultural or industrial tractors or self-propelled agricultural equipment.

ASAE is grateful to Deere & Co. for sponsoring the ASAE Distinguished Lecture Series.

Table of Contents

Introduction	5
History — Earlier Circuits.....	5
Typical Current Applications	5
Powershift Transmissions.....	5
Soft-Shift PTO Engagement.....	6
Power Splitter Type Gear Box.....	6
Power Shift Transmission.....	6
Soft-Shift PTO.....	6
Power Splitter.....	6
Electronic Driver (Power)	6
Generate Variable Force (Function Generator)	6
Operating Principle of Proportional Valve	7
Valve Features.....	7
Valve Function	7
De-energized Mode.....	7
Pilot Operations	7
Actuation Mode	7
Operating Characteristics.....	8
Application	8
Soft-Shift PTO.....	8
Flow Rating	9
Electric Connectors/Coils.....	9
Benefits.....	9

ELECTRIC/HYDRAULIC PROPORTIONAL CONTROL VALVES AND THEIR USE IN AGRICULTURE POWERSHIFT TRANSMISSIONS

Using recent innovations in electro/hydraulic proportional control, power train engineers have been able to accomplish improvements in agricultural tractor powershift transmissions. These provide smooth, consistent transfer of power regardless of gear speed transition range under all loads and operating conditions. An additional benefit provides for electronically duplicating the conventional mechanical clutch foot pedal inching feature used during implement load-up. Smooth vehicle inching control is retained to duplicate mechanical operation. These features provide ease of operation and comfort for the operator. Additional benefits include longer clutch, transmission, and driveline life.

INTRODUCTION

Powershift transmissions provide smooth, consistent transfer of tractive power regardless of ratio, speed, load, or operating conditions. Proportional control can accomplish this by precisely applying hydraulic pressure to engage the applicable ratio clutch pack, thus allowing engine torque to be carefully transferred through the drive train to the traction wheels. The machine operator simply selects the desired transmission ratio setting with the operating levers, initiating a microprocessor-based circuit to provide a modulated pulse width control signal to the electro/hydraulic proportional control valve. The proportional valve accepts hydraulic flow/pressure from a transmission-driven pump and directs the proportional valve to instantly fill the applicable clutch pack. Proper torque transfers during gear speed transition may be accomplished to provide smooth and uniform transmission of output torque during ratio engagement by programming the pressure rise rate to bring in and drop the clutch pack sets with complementary timing.

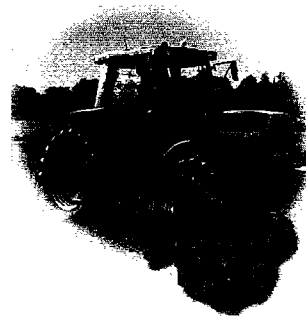

Figure 1—Powershift transmission.

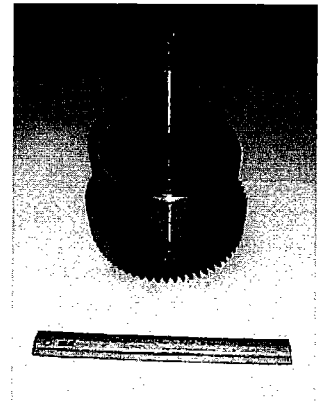

Figure 2—Clutch pack.

HISTORY — EARLIER CIRCUITS

Until recently, on/off type solenoid valves, accumulation and restriction valves were used to apply clutch pressure. Under this regimen, fluid temperature changes resulting in viscosity and specific volume changes negatively influence consistent, uniform clutch pressure control. This not only creates operator discomfort from rough shifts, but may contribute to early driveline failure.

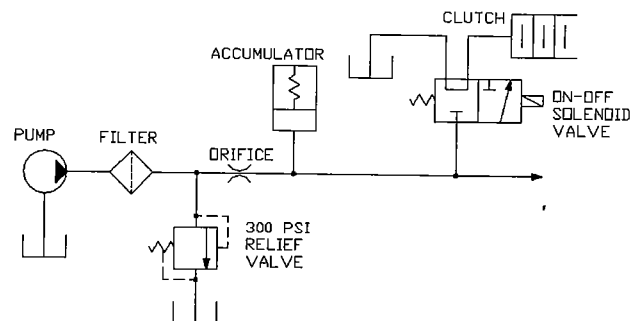

Figure 3—On/Off solenoid valve circuit.

TYPICAL CURRENT APPLICATIONS POWERSHIFT TRANSMISSIONS

- Agriculture tractors
- Construction equipment (all types)
- Agriculture fertilizer trucks

This ASAE Distinguished Lecture Series was prepared and presented at the Agricultural Equipment Technology Conference, 23-25 February, 2000, Kansas City, Missouri, by **Louis Harms** and **William Guse**, Fluid Power Systems Div of Parker Hannifin Corporation. For additional information, correspondence may be directed to: William Guse, 595 Schelter Rd., Lincolnshire, IL 60069, phone: 847-955-5000, fax: 947-821-9621, e-mail: <bguse@parker.com>.

SOFT-SHIFT PTO ENGAGEMENT

- Agriculture tractors
Reduce driveline impact and increase driveline system useful service life. This feature becomes more important with increased engine and implement size and capacity.

POWER SPLITTER TYPE GEAR BOX

- Agriculture spray truck
Need to smoothly engage liquid pumps on the fly on units now manufactured up to 400 HP.

POWER SHIFT TRANSMISSION

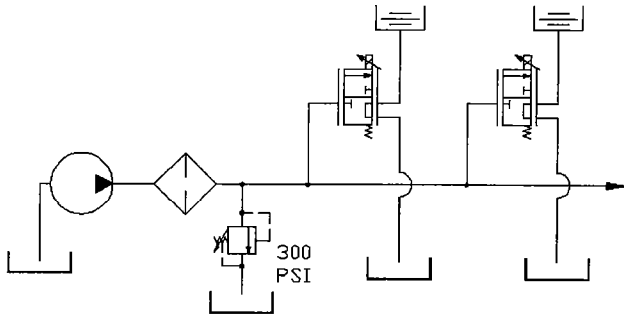

Figure 4-Powershift transmission.

SOFT-SHIFT PTO

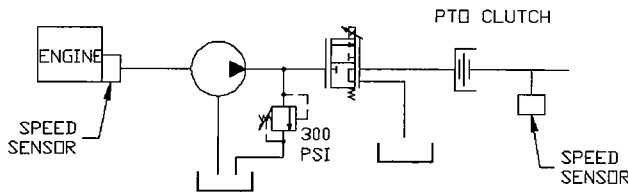

Figure 5-Soft-shift PTO.

POWER SPLITTER

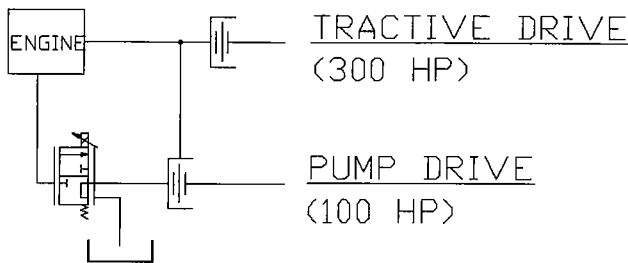

Figure 6-Power splitter.

ELECTRONIC DRIVER (POWER)

The electrical current used to operate an electro/hydraulic proportional valve is normally pulse-width-modulated direct current (PWM). This provides a precise method to generate linear axial force in the armature of a solenoid coil and at the same time create a slight dither to the solenoid armature, which minimizes hysteresis.

Variable axial force is generated by the solenoid armature in direct proportion to the applied current in the solenoid coil. Pulse width modulation type (chopped DC) electric current provides an effective means for application of precise coil current (i.e., solenoid force).

A microprocessor chip “chops” the standard constant 12 v DC supply voltage, that is, it turns it on and off at a specific fixed frequency effectively creating square waves of varying or “modulated” width. By changing the duration of the on time (modulation) it is possible to average the current level passing through the coil. For example, 10% on time results in 10% of full current, and 50% on time results in 50% of full current.

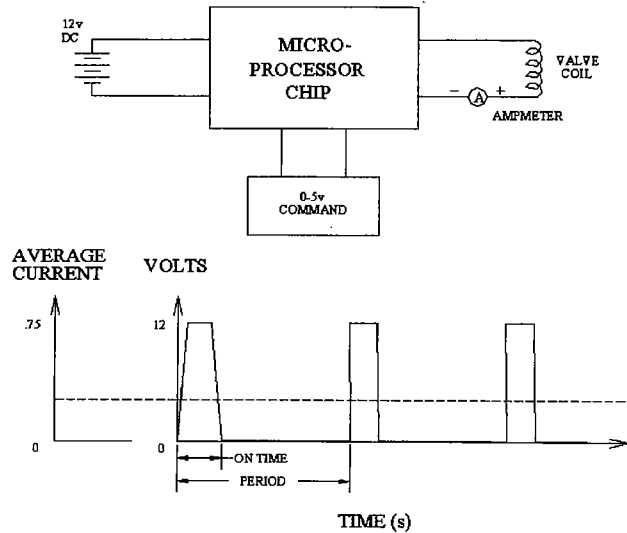

Figure 7-Electronic driver (power).

GENERATE VARIABLE FORCE (FUNCTION GENERATOR)

An electronic chip and programming software are necessary to generate a proportional variable current for the solenoid coil. This chip and software combination is referred to as a function generator and will proportionally control the solenoid coil axial force as a function of time.

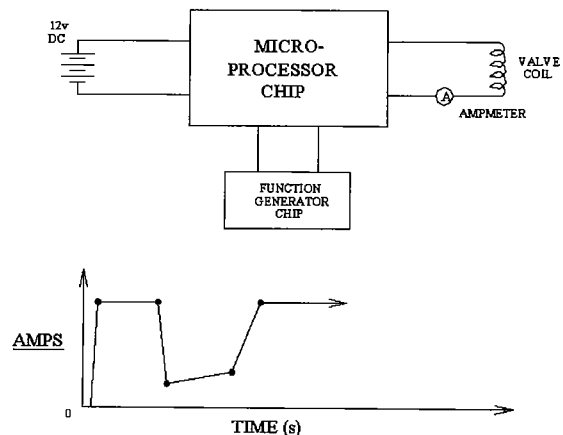

Figure 8-Function generator.

Manual lever actuation signals the PWM driver and controls the function generator to create a specific current trace. The coil current is absolutely consistent, repeatable, and predictable, and therefore can be used to precisely control the solenoid force being generated.

OPERATING PRINCIPLE OF PROPORTIONAL VALVE

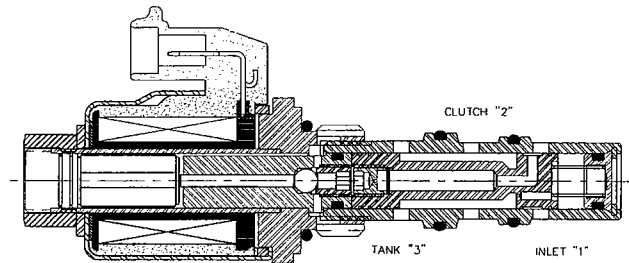

Figure 9—Proportional valve.

VALVE FEATURES

The electro-proportional pressure-reducing valve is a device in which pressure control is varied by a proportional change in current applied to the coil. The design may be unique in that the coil armature is not directly controlling the force on the spool, but the spool is pilot-operated to control the force via pressure communication to the regulating spool. This pilot operation provides for a simple armature configuration to generate the high force and stroke required to move the regulation spool with a high flow rate applied. The simple armature design illustrated here lends itself to low hysteresis and low amperage draw when compared to high force directly-actuated proportional coils. The pilot-operated design also makes the armature less sensitive to contamination that causes failure in many direct-acting designs.

VALVE FUNCTION

Port 1 acts as the supply or “inlet” port from the pump or other source. Port 2 is the regulated or reduced pressure port, commonly referred to as the “clutch” port. Port 3 is the “tank” port that connects to the sump or tank line. The tank port combines the pilot bleed flow and the clutch return flow through the same port. Care should be taken to prevent high pressure in the tank line that could actuate the clutch. Tank pressure is additive to the coil force applied to the pilot. The function of the EP3A-10 is to provide a regulated pressure to port 2 that is reduced from the inlet supply pressure. Since the pressure control feedback signal is fully based on port 2, variations in inlet pressure should not greatly affect the regulated pressure setting so long as the inlet pressure is higher than the desired reduced pressure.

DE-ENERGIZED MODE

In operation, supply flow enters port 1 where it is blocked by the spool from going to the clutch port (port 2; refer to figure). With the valve de-energized, flow is free to travel from the clutch port 2 to port 3, the tank port. An internal passage in the spool provides a connection from

the supply port 1 to the pilot chamber on the solenoid end. The passage from port 1 is always open to the pilot regardless of spool position in order to maintain a flow source to the pilot. Prior to reaching the pilot chamber, flow must pass through a filter screen and then an orifice. The screen traps large particles that could clog the orifice and prevent the valve from shifting. The orifice is also used to limit the flow into the pilot chamber. Flow coming into the pilot chamber then passes through the seat and past the ball which is free to travel when the solenoid coil is de-energized. This flow then travels out through slots on the outside threads of the valve to connect to port 3, the tank port. Because the ball has no restriction to the flow of fluid exiting the pilot chamber, no pressure is built up in the chamber to act against the spool end. A biasing spring is located on the opposite end of the spool to maintain the spool position and requires a nominal pressure of 15 PSI to start spool movement. When the fluid is cold, the normally unrestricted path for the pilot flow becomes more restricted on its path to tank. The bias spring prevents any slight pressure build-up from actuating the clutch.

PILOT OPERATIONS

To provide proportional control, the solenoid coil is energized by the use of a PWM signal with a varying duty cycle of 0% to 100%. An increased duty cycle acts to increase the effective current in the solenoid coil windings further causing an increase in the magnetic force. The force created is a function of the number of turns of wire in the coil and the current applied. An increase in current causes an increase in magnetic force between each component in the magnetic field. Each part becomes polarized with a north and south pole depending on the direction of current through the coil. Since opposite poles attract, the armature acts to move against the stationary pole piece in an attempt to close the air gap that is set in the valve during assembly. This action of the armature directly applies a force to the pushpin and the pushpin axially applies a force to the ball. The ball is pushed against the seat to oppose the force from the incoming pilot flow from the pilot chamber that was fed from the orificed supply. Increasing current to the solenoid coil creates an increase in force to seat the ball. The increased force provides a proportional increase in pressure built up in the pilot chamber, which moves the spool against the bias spring at the opposite end. With the ball fully against the seat (100% duty cycle), the flow past the seat is essentially stopped and the pressure in the pilot chamber is the same as the supply pressure at port 1. While a PWM direct current signal is normally used, it is also possible to operate the valve with a variable current from a power supply.

ACTUATION MODE

As noted in the de-energized mode, pilot flow is supplied from the inlet port 1 to the pilot chamber through a spool orifice and is unrestricted out past the ball and seat to the tank port 3. As the solenoid is energized with increasing current (or on duty %), the ball acts to restrict the flow path resulting in a pressure build-up in the pilot chamber proportional to the current applied. The pressure acts against the spool end to oppose the bias spring and open the flow from the supply port 1 to the clutch port 2,

while closing off the flow from the clutch port 2 to the tank port 3. (Pilot flow is still able to travel out to the tank port 3). Clutch port 2 pressure travels through a small hole at the end of the spool to provide clutch port pressure to the spring end of the spool. The orifice provides a flow path and also acts to dampen rapid spool movement. Pressure from the clutch port plus the bias spring force work to oppose the pilot chamber pressure to maintain a desired spool position. The spool position provides a corresponding reduced or regulated pressure at the clutch port that is independent from the inlet pressure variations. The spool moves to maintain a balance of opening from the supply to the clutch and from the clutch to the tank. In a regulating mode, if the clutch pressure were to drop, the pilot chamber pressure less the spring bias would be higher than the clutch port pressure. This would cause the spool to be unbalanced and shift to open the supply to the clutch port. Once the clutch pressure is returned to the desired pressure, the pressure balances the spool and the pressure at the clutch is maintained. The same is true when the pressure at the clutch is higher than the pilot chamber pressure less the bias spring pressure. The force unbalance moves the spool to open the clutch port to the tank port until the spool is balanced with the pressures. The valve spool internal action comprises a closed loop servomechanism where feedback gains of the various components and component masses must be finely tuned to provide rapid action, yet remain stable during operating conditions.

OPERATING CHARACTERISTICS

Figure 10 illustrates the relationship of electrical input current and time and how it affects the clutch piston displacement and clutch engagement pressure. Notice the clutch pack fill characteristics that enable the clutch piston to reach the “kiss” point and smoothly engage the clutch to transmit the torque. Clutch release can also be controlled at a predetermined rate by the current ramp rate.

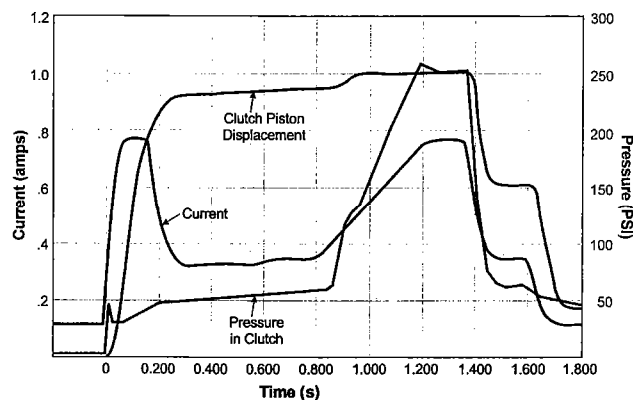

Figure 10—EP3A-10 clutch engagement sequence (typical).
 Current: 200 Hz PWM (RMS average shown)
 Fluid: SAE 10, 100°F, (38°C) 260 PSI supply

APPLICATION

The most common application for the PWM valve is as a device to control the pressure available to a power train

clutch. The clutch force generating cylinder functions much like a spring returned single acting cylinder requiring hydraulic pressure on the piston to extend the cylinder rod. Common applications require about 25 PSI to initiate the actuation of the clutch piston. As the piston moves the clutch plates start to engage or kiss (at about 35 to 50 PSI). Initially the plates slip so that the load is engaged smoothly. As pressure is increased to the piston, the clutch plates continue to engage gripping the clutch separator plates until there is no longer any slippage (at about 150 PSI in most designs). Also, most designs provide a low-pressure oil supply of about 300 PSI to actuate the clutches as well as to provide lubricating flow to clutches and bearings. When a clutch begins to fill, it is nearly empty and only has the fluid that has remained in the lines. If the pressure is ramped up slowly to the clutch, the engagement of the plates will be smooth and the corresponding acceleration of the output will be smooth. With each shift, it is possible that the line may have different amounts of fluid left in it from the last engagement. This variation can result in variation in the time it takes to fill the clutch and engage. It is recommended that the connection from the clutch port to the clutch be filled with fluid and not be allowed to drain down. This will keep shift times more consistent. The time that it would take to fill the clutch by ramping up the pressure would be too slow when compared to the shifting of a manual clutch. To overcome this problem, the PWM is fully energized for a short period of time to fill the clutch rapidly, although not allowed to build up full pressure to kiss the clutch plates and cause the machine to jerk. Once the clutch is filled, the current to the valve is reduced to maintain a pressure just below the kiss point. The pressure is then slowly ramped up under microprocessor control to engage the clutch.

SOFT-SHIFT PTO

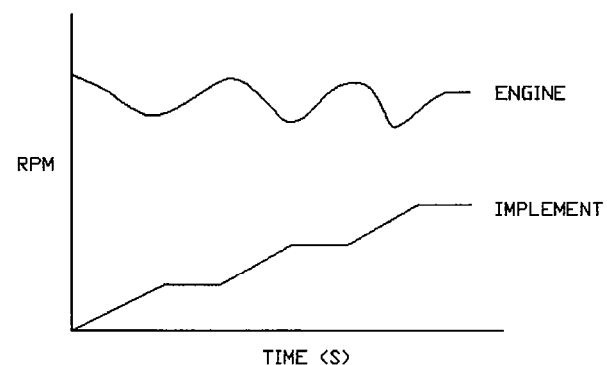

Figure 11—Microprocessor integrates speed sensors and provides proper acceleration of implement.

FLOW RATING

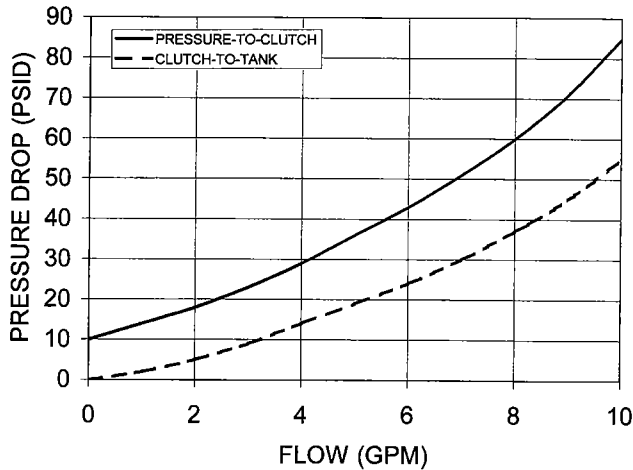

Figure 12-EP3A-10 pressure drop vs. flow (cartridge only).
39 cSt (182 SSU) oil @ 104°F (40°C)

ELECTRIC CONNECTORS/COILS

An encapsulated coil with an integral connector provides a waterproof configuration that is environmentally sealed and also immune to harsh chemicals, high temperatures, corrosion, and thermal shock. The common voltages are 12 and 24 v DC and are capable of continuous duty applications for infinite life.

BENEFITS

ACCURACY

Smooth, consistent, repeatable pressure control without need for pressure sensors.

DURABILITY

Multi-million operating cycles without any loss in performance. Over 1,000,000 valves in global service with all major agriculture firms.

RESPONSE TIME

0.080 s (pull-in)
0.040 s (drop-out)

CONTAMINATION TOLERANT

Successfully completed every contamination test conducted by global major users.

STABLE PERFORMANCE

No chatter or instability.

AUTOMATIC AIR PURGE

No air bleed or start-up operating cycles required.

SOLENOID COIL

Patented coil design provides environmental sealing. Coil rated for continuous duty with +275°F (135°C) ambient temperature. Meets all applicable salt spray tests.

LOW ELECTRICAL POWER

0.150 to 0.750 amp using 100 to 400 Hz PWM

OPERATING TEMPERATURE

-40°F (-40°C) to +250°F (121°C)

ZERO CLUTCH PRESSURE AT -40°F (-40°C)

Low clutch drag to allow cold engine cranking.

VERSATILE

One proportional valve per clutch provides smooth shifts under heavy loads in hilly terrain by interfacing microprocessor controllers with the transmission engaging and disengaging clutches in the programmed sequence and with proper pressure rise/fall rates. Precise inching control during implement hookup is possible by using a proportional valve controlled by a clutch pedal equipped with a potentiometer. A simplified circuit can use one proportional valve and 2-position, 3-way selector valves at each clutch, but this arrangement may cause load jerk at heavy loads and in hilly terrain.

CALIBRATION

No calibration is required to utilize the proportional valve. Proven one-time-only factory calibration of the control box due to a narrow performance band with no deterioration.

CLUTCH WEAR

Smooth, consistent, repeatable shifts minimize clutch wear and component damage to the extent that recalibration is not required, especially with sintered iron clutch material.

Microprocessor provides built-in dwell following fill cycle to compensate for wear should it occur.

CONTROL

Input and output RPMs provide excellent feedback for the closed-loop system.

TEMPERATURE COMPENSATION

Slight pressure performance shift may occur at low temperatures and can be compensated for by incorporating a temperature sensor to update the fill cycle.

SUMMARY

Power train engineers now have the ability to precisely control the torque being transmitted by the clutch. The PWM valve and its associated electronic control package provides smooth consistent transfer of power regardless of gear speed transition range or direction control under all loads and operating conditions. This enables longer and more controlled clutch and transmission life as well as providing better operator control with improved comfort.