

Available online at www.sciencedirect.com ScienceDirect

Chinese Journal of Aeronautics 23(2010) 117-122

**Chinese
Journal of
Aeronautics**www.elsevier.com/locate/cja

A New Measurement Method for Unbalanced Moments in a Two-axis Gimbaleed Seeker

Yu Shuang, Zhao Yanzheng*

School of Mechanical Engineering, Shanghai Jiaotong University, Shanghai 200240, China

Received 19 November 2008; accepted 21 August 2009

Abstract

This article presents a novel method to measure unbalanced moments in a two-axis gimbaleed seeker commonly believed to seriously influence the tracking accuracy and stabilizing capability. This method enables individual measurement of unbalanced moments, and judgment of the seeker's status—balanced or not. Furthermore, an instrument is designed based on this method and calibrated. The effectiveness of the proposed method is validated through a simulation. The experimental results show a satisfied level of accuracy the measurements have. This work forms a basis for the further development of a more stabilized gimbaleed seeker with less induced vibration and consumed power.

Keywords: gimbaleed seeker; weight sensors; measurement; unbalanced

1. Introduction

Gimbaleed seekers have found wide applications in modern advanced tactical missiles. Used to track the target and stabilize the antenna's pointing vector, the system is mainly of a two-axis type inclusive of an inner and an outer gimbal^[1-2]. However, disturbance torques are always generated by the mass imbalance and the gimbal geometry during it moving and vibrating^[2-5]. The induced disturbance torque is known as the unbalanced moment.

Presence of unbalanced moments leads to a considerable reduction in the motor torques, thus causing position errors and even downgrading the seeker's tracking accuracy and stabilizing ability^[6-7]. The most popular tool to eliminate the troubles is to counteract them with counterweights^[8-9]. It is the process, in which, an extra mass is added to the gimbal at a specific locations to shift its center of gravity (CG) to the center of rotation.

However, there exist two unbalanced moments on other two axes of each gimbal except the rotational axis. The four unbalanced moments cannot be measured individually and directly, for the inner and outer

gimbals are connected in series, which is naturally accompanied by coupling effects. Therefore, it is almost impossible to accurately determine the added mass and its location for each gimbal in applying the counterweights, which makes it necessary to have resort to estimation and/or experience at present^[10].

Rather too limited work has been devoted to the measurement of the unbalanced moments of a gimbaleed seeker. In space electronics, there was introduced the idea of orienting the gimbal axes at 45° to the horizontal and measuring the changes in horizontal CG position as the gimbal rotates about its axis^[9]. C. L. Lin and Y. H. Hsiao built the model of disturbance moment induced by seeker's mass imbalance according to the squares of the missile body's angular rate, angular acceleration and lateral acceleration^[11]. From the above-cited work, it is clear that to measure the unbalanced moments in a two-axis gimbaleed seeker remains challenging.

This study proposes a brand-new method to measure the unbalanced moments in each gimbal for a two-axis gimbal seeker. On the basis of the method, a measuring instrument with three weight sensors is designed and calibrated. Then simulations are performed to demonstrate the effectiveness of the method. Finally, some experiments are carried out on the instrument with the measurement errors discussed.

*Corresponding author. Tel.: +86-21-34206308.
E-mail address: yzh-zhao@sjtu.edu.cn

2. Measurement Method

2.1. Measurement concept

Fig.1 shows the schematic representation of a gimbaled seeker, which illustrates both gimbals connected in series with the outer gimbal mounted on the base and the inner gimbal on the outer gimbal. The antenna, not shown, is disposed on the inner gimbal. Let y, z be the rotational axes of the outer and inner gimbals respectively; O the center of rotation; λ_o the angular displacement of the outer gimbal relative to the base and λ_i the angular displacement of the inner gimbal relative to the outer gimbal.

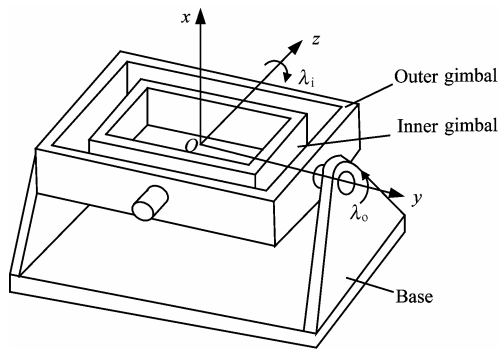

Fig.1 Scheme of a gimbaled seeker.

In order to balance the gimbaled seeker, the counterweight should be so designed as to shift the CG of each gimbal to the center of rotation. To do this, a method has been developed beforehand to predetermine the accurate unbalanced moments. By this method, the gimbaled seeker to be measured is placed on a platform supported by three weight sensors. The connection between the measurement platform and each sensor is designed to be of one point-contact and unconstrained type. This is to ensure that the whole weight of the gimbal acts on the sensors without any force from other directions and also the sensors' force-bearing points do not subject to changes in the measurement process. The unbalanced moments of the gimbal are determined by measuring the change of three weight sensors' outputs when the inner and outer gimbals rotate by different angular orientations. If the gimbals are in balance, the outputs from all weight sensors will not change no matter which angular orientations the rotating gimbals take.

Fig.2 illustrates the principles of the measurement method. The coordinate frame $O'y'z'$ is parallel to Oyz . The three sensors' force-bearing points are denoted by the coordinates in $O'y'z'$, i. e. $D_1(0,0)$, $D_2(y_2, z_2)$, $D_3(y_3, z_3)$ respectively.

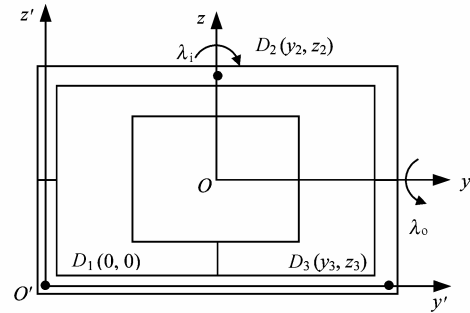

Fig.2 Principles of a measurement method.

The measurement involves the following steps:

Step 1 Place a gimbal seeker on the measurement platform.

Step 2 Calibrate the coordinates of the sensors' force-bearing points $D_2(y_2, z_2)$ and $D_3(y_3, z_3)$.

Step 3 Record the three sensors' outputs when the two gimbals are held at the zero angular orientation.

Step 4 Record the three sensors' outputs when the outer gimbal is held at the zero angular orientation and the inner gimbal rotates by two angular displacements $\pm\lambda_i$ ($\lambda_i > 0$).

Step 5 Record the three sensors' outputs when the inner gimbal is held at the zero angular orientation and the outer gimbal rotates by two angular displacements $\pm\lambda_o$ ($\lambda_o > 0$).

Step 6 Calculate the unbalanced moments.

2.2. Calculation of unbalanced moments

In Step 4, according to the principles of moment balance, the moment generated by the total weight of the inner and outer gimbals about the point O' must equal the sum of each sensor's pressure multiplied by the force arm from the sensor's force-bearing point to the point O' . Thus the moment balance equations about the point O' along y' -axis can be obtained.

Furthermore, the unbalanced moment of an inner gimbal can be mathematically expressed by

$$G_i x_i = \frac{1}{2 \sin \lambda_i} [(P_{2zp} - P_{2zn})y_2 + (P_{3zp} - P_{3zn})y_3] \quad (1)$$

$$G_i y_i = \frac{1}{2(1 - \cos \lambda_i)} [(2P_{2zz} - P_{2zp} - P_{2zn})y_2 + (2P_{3zz} - P_{3zp} - P_{3zn})y_3] \quad (2)$$

where G_i is the weight of the inner gimbal; x_i, y_i are the CG offsets of the inner gimbal along x - and y -axis respectively; P_{jkl} ($j = 1, 2, 3; k = z, p, n; l = z, p, n$) is the sensor output at position D_j when the outer gimbal rotates by k angular displacements and the inner gimbal by l angular displacement; z, p, n denote the gimbal at fixed state and the gimbal rotates by λ_o (λ_i)

and $-\lambda_o(-\lambda_i)$ angular displacements respectively.

From Eqs. (1)-(2), the unbalanced moments of the inner gimbal are generated by the CG offsets along x - and y -axis while the offset along z -axis does not affect the unbalanced moment because the inner gimbal rotates about z -axis.

Also the moment balance equations about the point O' along z' -axis can be obtained from Step 5. From them, the unbalanced moment for outer gimbal can be mathematically expressed by

$$G_o x_o = \frac{1}{2 \sin \lambda_o} [(P_{2zn} - P_{2zp})y_2 + (P_{3zn} - P_{3zp})y_3] + \frac{1}{2 \sin \lambda_i} [(P_{2nz} - P_{2pz})z_2 + (P_{3nz} - P_{3pz})z_3] \quad (3)$$

$$G_i z_i + G_o z_o = \frac{1}{2(1 - \cos \lambda_o)} [(2P_{2zz} - P_{2pz} - P_{2nz})z_2 + (2P_{3zz} - P_{3pz} - P_{3nz})z_3] \quad (4)$$

where G_o is the weight of the outer gimbal; x_o, z_o are the CG offsets of the outer gimbal along x - and z -axis respectively and z_i is the CG offset of the inner gimbal along z -axis.

From Eqs.(3)-(4), the unbalanced moment of the outer gimbal is generated by the CG offset of outer gimbal along x -axis and the CG offset of the two gimbals along z -axis while the offset along y -axis has nothing to do with the unbalanced moment as it rotates about y -axis.

From the analysis and by the above-mentioned, the unbalanced moments of the inner gimbals, $G_i x_i$ and $G_i y_i$, and the outer gimbals, $G_o x_o$ and $G_i z_i + G_o z_o$, can be calculated from the measurement results. It can also be seen that the location of the seeker on the measurement platform exerts no effect on the results of the calculated unbalanced moment.

By using this method, the unbalanced moment about each axis can not only be measured accurately, but also be judged if a two-axis gimbaled seeker is balanced.

3. Calibration Method

In using the proposed method, the sensors need to be calibrated to know how large a pressure should be applied. The weight sensors are made of aluminum and U-shaped slots are cut to transfer the maximal tension to the vibrating strip when a force is applied to the end of the frame. The sensors can be calibrated through measuring the sensors' outputs under certain static loads^[12-13]. By recording the loads and the sensor's outputs corresponded thereto, the two sets of data can be related to form a calibration matrix.

Besides the aforesaid sensors, the coordinates of sensors' force-bearing points, $D_2 (y_2, z_2)$ and $D_3 (y_3, z_3)$, are required to calibrate. To do this, a steel ball is placed on each of the three different round holes in the measurement platform, the locations of each hole's center in the frame $O'y'z'$ being (y_a, z_a) , (y_b, z_b) , (y_c, z_c) (where $z_a > z_b, z_a > z_c$ and $y_c > y_b > y_a$) respectively. The diameter of the steel ball should be slightly bigger than that of the holes to allow the center of the ball coincident with the center of the holes horizontally.

The mass of the steel balls and their relative positions of the holes in the $O'y'z'$ frame are predetermined by means of a balance and a microscope respectively. According to the principles of moment balance, the coordinates of D_2 and D_3 can be defined as

$$y_2 = G_m [(F_{3a} - F_{3b})(y_a - y_c) - (F_{3a} - F_{3c})(y_a - y_b)] / F \quad (5)$$

$$y_3 = G_m [(F_{2a} - F_{2c})(y_a - y_b) - (F_{2a} - F_{2b})(y_a - y_c)] / F \quad (6)$$

$$z_2 = G_m [(F_{3a} - F_{3b})(z_a - z_c) - (F_{3a} - F_{3c})(z_a - z_b)] / F \quad (7)$$

$$z_3 = G_m [(F_{2a} - F_{2c})(z_a - z_b) - (F_{2a} - F_{2b})(z_a - z_c)] / F \quad (8)$$

$$F = (F_{2a} - F_{2c})(F_{3a} - F_{3b}) - (F_{2a} - F_{2b})(F_{3a} - F_{3c}) \quad (9)$$

where G_m is the weight of the ball and F_{js} ($j = 1, 2, 3, s = a, b, c$) the sensor output at position of D_j when the ball is placed at the position s .

4. Validation Through Simulation

In order to validate the proposed method, a simulation model of the measurement instrument with an unbalanced gimbaled seeker is built in Automatic Dynamic Analysis of Mechanical System (ADAMS) software. Then the unbalanced moments can be calculated with the software. In the simulation, the coordinate system is set to follow the definition in Fig.2 and the accuracy of each sensor is specified to be 1 mg. According to Eqs.(1)-(4), the measurement errors of the unbalanced moment decrease with the increase of the angular displacements $\lambda_o(\lambda_i)$. Since the maximal angular displacement of the two gimbals is 30° , both λ_o and λ_i are set to be 30° .

The whole simulation process involves the steps in Section 2.1. According to the sensor outputs from each step and Eqs.(1)-(4), the unbalanced moments for each gimbal can be obtained. Table 1 shows the comparison between the calculated and the measured unbalanced moments. It can be discovered that the

measured values are very close to the calculated ones with the measurement errors less than 1 g·cm, which evidences the effectiveness of the proposed method.

Table 1 Comparison of unbalanced moments

Unbalanced moment	Value/(g·cm)	
	Calculated	Measured
$G_i x_i$	-28.16	-28.21
$G_i y_i$	-42.24	-42.54
$G_o x_o$	-56.32	-55.80
$G_i z_i + G_o z_o$	213.29	212.39

5. System Design and Experimental Results

Based on the presented method, an instrument for measuring unbalanced moments is developed. In it, the sensor's load accuracy of each strain gage is 1/10 000 and the measurement range is 0-1 kg. The sensor outputs are sampled by a 16-bit analog/digital (AD) data acquisition card and the final results are attained by averaging 100 data, which have been processed by the inter function of the AD card.

5.1. Calibration results

In calibrating weight sensors, the loads and the sensor outputs corresponded thereto are recorded when the weights up to 1 kg are applied to the end of frame and, by using the least square method, the relational expressions of three sensors can be described by

$$\begin{bmatrix} v_1 \\ v_2 \\ v_3 \end{bmatrix} = \begin{bmatrix} 10.003 & 30 \\ 10.000 & 02 \\ 10.000 & 14 \end{bmatrix} m + \begin{bmatrix} 0.001 & 15 \\ 0.000 & 72 \\ 0.001 & 06 \end{bmatrix} \quad (10)$$

where v_1 , v_2 and v_3 denote each sensor's output(V)and m the applied load(kg). The three weight sensors are shown to possess excellent linearity and repeatability from a series of measurement tests.

In calibrating the coordinates of the sensors' force-bearing points, the accuracy of the balance and the microscope is so high, i. e. within 1 mg and 1 μm respectively, that the errors from the two instruments can be neglected. In order to decrease the calibration errors, the final calibration results are obtained by averaging the results from repeated measurements. Table 2 lists the calibration results after digital filter processing in eight tests.

Table 2 Coordinates of sensors' force-bearing points

Test number	Value/ mm			
	y_2	z_2	y_3	z_3
1	102.164 2	179.671 1	207.296 3	0.646 1
2	102.539 7	179.392 7	207.697 5	0.602 5
3	102.255 1	179.408 5	207.254 2	0.752 2
4	102.275 0	179.201 1	207.468 8	0.820 9
5	102.280 9	179.219 5	207.034 3	0.754 5
6	102.200 5	179.699 2	207.642 6	0.655 6
7	102.383 9	179.347 5	207.421 1	0.788 6
8	102.332 7	179.512 4	207.354 6	0.642 5

According to the theoretical analysis, it is reasonable that the calibration results fluctuate within 1 mm by using the sensors with the accuracy of 100 mg. From Table 2, it can be seen that the range within measurement data vary is about 0.5 mm. This is far better than the given value.

5.2. Measurement results and discussions

After calibrating each sensor and the coordinates of sensors' force-bearing points, a two-axis gimbaled seeker to be measured is placed on the measurement platform and tested according to the steps specified in Section 2. 1. The test is repeated eighteen times with the results shown in Fig.3.

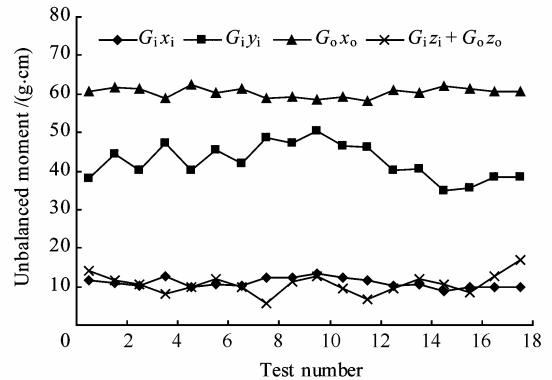

Fig.3 Measurement results of unbalanced moments.

By the error estimation theory^[14-16], the measurement errors are calculated when the confidence level is 99. 7%. The results are listed below:

$$\begin{aligned} |\Delta G_i x_i| &= 3.69 \text{ g}\cdot\text{cm} \\ |\Delta G_i y_i| &= 13.98 \text{ g}\cdot\text{cm} \\ |\Delta G_o x_o| &= 3.83 \text{ g}\cdot\text{cm} \\ |\Delta(G_i z_i + G_o z_o)| &= 7.91 \text{ g}\cdot\text{cm} \end{aligned}$$

From Eqs.(1)-(4), the maximum measurement errors of unbalanced moments are

$$\begin{aligned} |\Delta G_i x_i| &= 3.34 \text{ g}\cdot\text{cm} \\ |\Delta G_i y_i| &= 21.29 \text{ g}\cdot\text{cm} \\ |\Delta G_o x_o| &= 4.18 \text{ g}\cdot\text{cm} \end{aligned}$$

$$|\Delta(G_{iz_1} + G_{oz_0})| = 16.49 \text{ g}\cdot\text{cm}$$

The permissible measurement error of the instrument for each unbalanced moment is set to be $50 \text{ g}\cdot\text{cm}$, and it can be seen that most of the experiment errors are well below the specified value. This means the experiment results are satisfied. The measurement errors are affected by several factors: the sensor's accuracy, the coordinates of sensors' force-bearing points, the angular displacements of each gimbal and environmental variants, such as vibration, radiation, wind and air-stream, etc. Among them, the sensor's accuracy gets overwhelming position over others, for it accounts for more than 86%; and, what's more, it affects of itself the calibration accuracy of the coordinates of sensors' force-bearing points. Therefore, the sensors play a decisive role in the measurement instrument.

From Fig.3, it can be observed that though the measured values fluctuate in a broad range, they are still constrained to an acceptable extent. Table 3 lists the results by averaging the measurement values and calculating the total unbalance about y -axis and z -axis.

The unbalanced moments in Table 3 provide the data required to determine the amounts and locations of added weights for a two-axis gimbale seeker, which enables the unbalanced moments to be limited to an allowable value.

Table 3 Unbalanced moments of a gimbale seeker

Gimbal	Condition	Value(g·cm)
Inner	Along x -axis about z -axis (G_{ix})	10.98
	Along y -axis about z -axis (G_{iy})	42.53
	Total unbalance about z -axis	43.92
Outer	Along x -axis about y -axis (G_{ox})	60.37
	Along z -axis about y -axis ($G_{iz_1} + G_{oz_0}$)	10.68
	Total unbalance about y -axis	61.31

Both the simulation and the experiment have borne out the effectiveness of the proposed method. Nevertheless, there is left a problem that the measurement errors, satisfied though, may not be qualified for the higher performances of a seeker as a result of the limited sensor's accuracy of the strain gage load. One way to contain the problem is to employ other type of sensors, such as electromagnetic one, capable of measuring force to within about 0.000 1%. This constitutes one of contents of our future work.

6. Conclusions

This article has advanced a new method to measure unbalanced moments in a two-axis gimbale seeker. It is superior to other counterparts in that each unbalanced moment can be measured directly and individually although the inner and outer gimbals are

connected in series, and the seeker's location on the measurement platform cuts no ice with the measurement results. Furthermore, a measurement instrument is designed based on this method with its calibration methods studied.

The proposed method is verified against the simulation results in ADAMS software. And then the measurement tests are carried out on the designed instrument. The results show that the errors of most experiment data are well under the specified permissible ones. Admittedly, however, satisfied though the measurement accuracy may be, it might be insufficient for the higher performances of a seeker owing to the limited sensor's own accuracy. To solve the problem is one of the objectives of our future work. Anyway, the research has laid the foundation for us to push ahead with the project to develop high-performance gimbale seekers.

References

- [1] Kennedy P J, Kennedy R L. Direct versus indirect line of sight (LOS) stabilization. *IEEE Transactions on Control Systems Technology* 2003; 11(1): 3-15.
- [2] Yu S, Zhao Y Z. Simulation study on a friction compensation method for the inertial platform based on the disturbance observer. *Proceedings of the Institution of Mechanical Engineers, Part G:Journal of Aerospace Engineering* 2008; 222(3): 341-346.
- [3] Ge L Z, Shen Y, Gao Y F, et al. Head pursuit variable structure guidance law for three-dimensional space interception. *Chinese Journal of Aeronautics* 2008; 21(3): 247-251.
- [4] Ekstrand B. Equations of motion for a two-axes gimbal system. *IEEE Transactions on Aerospace and Electronic Systems* 2001; 37(3): 1083-1091.
- [5] Tang L, Chen Y Q. Model development and adaptive imbalance vibration control of magnetic suspended system. *Chinese Journal of Aeronautics* 2007; 20(5): 434-442.
- [6] Boynton R, Wiener K, Kennedy P, et al. Static balancing a device with two or more degrees of freedom. *Proceedings of the 62nd Annual Conference of Society of Allied Weight Engineers*, 2003.
- [7] Hu H J, Yu Y S. Moment coupling analysis and compensation control of flight simulator. *Journal of System Simulation* 2006; 18(8): 886-891. [in Chinese]
- [8] Wang Z W, Li Y B, Li J. Study on the mechanics property of three degrees of freedom air-bearing testbed compensation for the unbalance torque. *Chinese Journal of Mechanical Engineering* 2006; 42(4): 185-190. [in Chinese]
- [9] Ritchie M, Ghali A, Dilger W, et al. Unbalanced moment resistance by shear in slab-column connections:experimental assessment. *ACI Structural Journal* 2006; 103(1): 74-82.
- [10] Laliberté T, Gosselin C M, Jean M. Static balancing of 3-DOF planar parallel mechanisms. *IEEE/ASME Transactions on Mechatronics* 1999; 4(4): 363-377.
- [11] Lin C L, Hsiao Y H. Adaptive feedforward control

- for disturbance torque rejection in seeker stabilizing loop. *IEEE Transactions on Control Systems Technology* 2001; 9(1): 108-121.
- [12] Parsa K, Aghili F. Adaptive observer for the calibration of the force-moment sensor of a space robot. *Proceedings of IEEE International Conference on Robotics and Automation*. 2006; 1667-1673.
- [13] Ramakrishnan S, Philip J. An optically activated resonant force sensor calibrated as a weighing balance. *Measurement Science and Technology* 1991; 2(6): 549-552.
- [14] Shalabh, Garg G, Misra N. Use of prior information in the consistent estimation of regression coefficients in measurement error models. *Journal of Multivariate Analysis* 2009; 100(7): 1498-1520.
- [15] Savelkaev S V. A variational method of estimating the total measurement error of microwave-circuit analyzers. *Measurement Techniques* 2008; 51(12): 1323-1328.
- [16] Wang Z S, Ning B F, Jiao M G, et al. Evaluation on test error of weight and center of gravity of self-propelled gun. *Journal of Gun Launch and Control*

2005(2): 59-61. [in Chinese]

Biographies:

Yu Shuang Born in 1980, she received B.S. and M.S. degrees from Harbin University of Science and Technology in 2002 and 2005 respectively. Now she is a Ph.D. candidate in School of Mechanical Engineering, Shanghai Jiaotong University. Her main research interest includes balance and dynamics of mechatronic systems.
E-mail: yushuang_@sjtu.edu.cn

Zhao Yanzheng Born in 1965, he received B.S., M.S. and Ph.D. degrees from Harbin Institute of Technology in 1985, 1988 and 1999 respectively. He is currently a professor in the School of Mechanical Engineering, Shanghai Jiaotong University. His main research interests include design and application of wall-climbing robot, bionics robot, etc.
E-mail: yzh-zhao@sjtu.edu.cn