

Accepted Manuscript

Title: Trends in Microfluidic Systems for *In Situ* Chemical Analysis of Natural Waters

Author: Adrian M. Nightingale Alexander D. Beaton
Matthew C. Mowlem



PII: S0925-4005(15)30148-9
DOI: <http://dx.doi.org/doi:10.1016/j.snb.2015.07.091>
Reference: SNB 18822

To appear in: *Sensors and Actuators B*

Received date: 8-5-2015
Revised date: 12-7-2015
Accepted date: 22-7-2015

Please cite this article as: A.M. Nightingale, A.D. Beaton, M.C. Mowlem, Trends in Microfluidic Systems for *In Situ* Chemical Analysis of Natural Waters, *Sensors and Actuators B: Chemical* (2015), <http://dx.doi.org/10.1016/j.snb.2015.07.091>

This is a PDF file of an unedited manuscript that has been accepted for publication. As a service to our customers we are providing this early version of the manuscript. The manuscript will undergo copyediting, typesetting, and review of the resulting proof before it is published in its final form. Please note that during the production process errors may be discovered which could affect the content, and all legal disclaimers that apply to the journal pertain.

manuscript

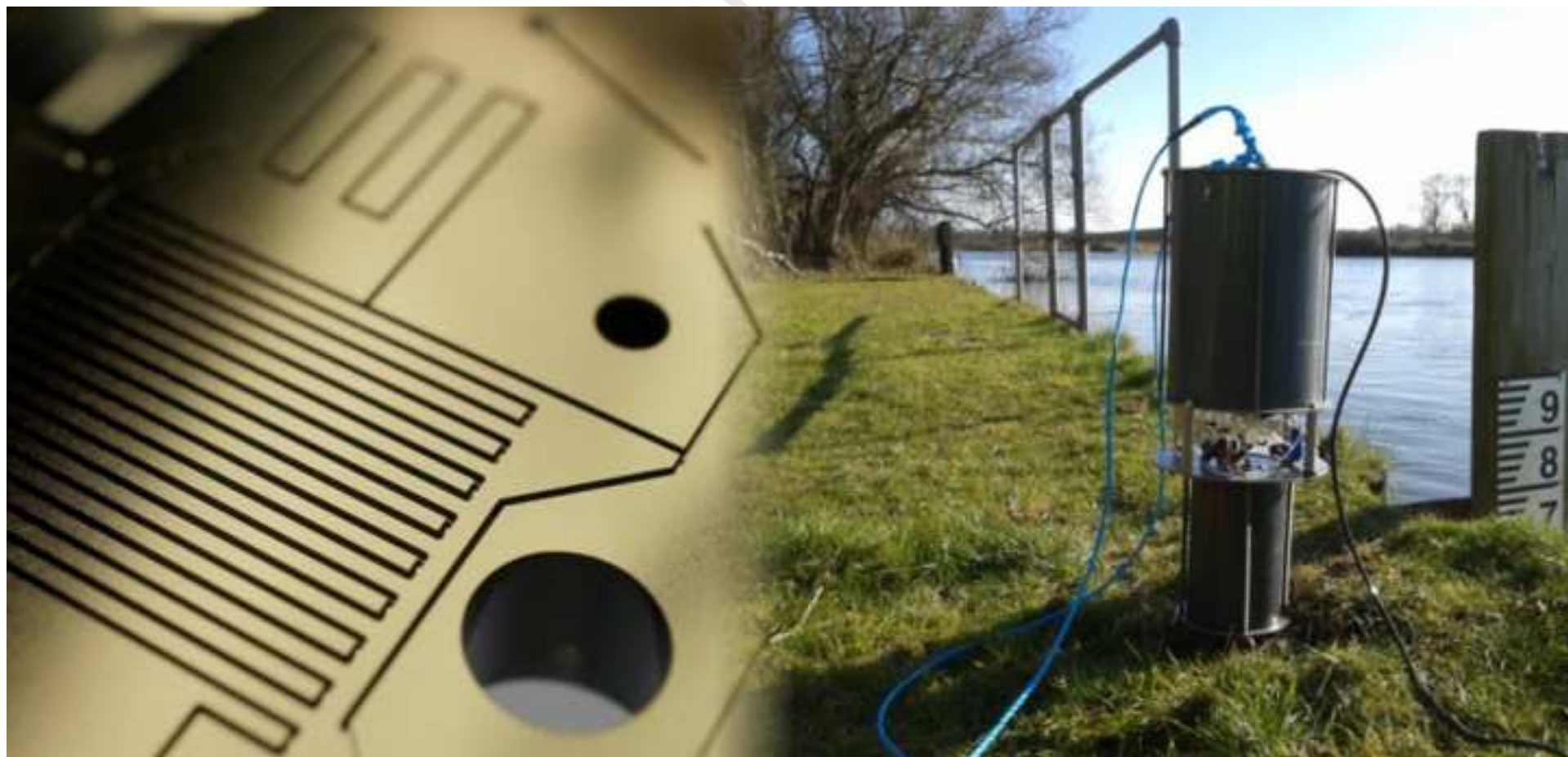

Trends in Microfluidic Systems for *In Situ* Chemical Analysis of Natural Waters

Adrian M. Nightingale,^{a*} Alexander D. Beaton,^{b*} Matthew C. Mowlem.^b

^a*Faculty of Engineering & the Environment, University of Southampton, Highfield, Southampton, United Kingdom. SO17 1BJ*

^b*National Oceanography Centre, European Way, Southampton, United Kingdom. SO14 3ZH*

*a.nightingale@southampton.ac.uk, +44 (0)2380 592873; a.beaton@noc.ac.uk
+44 (0)2380 596268

ABSTRACT

Spatially and temporally detailed measurement of ocean, river and lake chemistry is key to fully understanding the biogeochemical processes at work within them. To obtain these valuable data, miniaturised *in situ* chemical analysers have recently become an attractive alternative to traditional manual sampling, with microfluidic technology at the forefront of recent advances. In this short critical review we discuss the role, operation and application of *in situ* microfluidic analysers to measure biogeochemical parameters in natural waters. We describe recent technical developments, most notably how pumping technology has evolved to allow long-term deployments, and describe how they have been deployed in real-world situations to yield detailed, scientifically useful data. Finally, we discuss the technical challenges that still remain and the key obstacles that must be negotiated if these promising systems are to be widely adopted and used, for example, in large environmental sensor networks and on low-power underwater vehicles.

1. INTRODUCTION

Determining the variation and distribution of aqueous chemical species within oceans, lakes and rivers (natural waters) is fundamental in studying the biogeochemical cycles that underpin elemental transport and biological productivity around the globe. Measurements of nutrients (e.g. nitrate, phosphate and silicate), trace metals (e.g. dissolved iron and manganese), carbonate system parameters (pH, dissolved inorganic carbon, total alkalinity and $p\text{CO}_2$) and other dissolved gases (e.g. oxygen and methane) are all required together with contextual measurements of physics and biology to characterise the state of our aquatic ecosystems.[1–5]

Traditionally most chemical parameters are measured by sampling: water is collected at known locations and times, preserved and then transported to a laboratory for analysis using standard methods such as colorimetry, fluorescence or atomic absorption spectroscopy.[6] *In situ* analytical devices operate differently. By analysing the water in the environment the risk of sample degradation or contamination is obviated and sample preservation and transportation logistics are removed - allowing higher measurement frequency and uninterrupted continuous measurement in remote locations. Furthermore, if the device can be deployed on a mobile platform such as a submersible vehicle, we can obtain a spatially detailed map of chemical composition. Consequently, *in situ* chemical sensors have a unique and important role to play in environmental measurement and monitoring.

While some chemical parameters can be addressed using solid state sensors (e.g. pH,[7,8] oxygen,[9,10] $p\text{CO}_2$ [11,12]and nitrate[13–16]) many cannot be measured with sufficient accuracy. As a result many *in situ* analysers are based around a flow system which can draw a sample from the environment, chemically treat it (typically by adding one or more reagents to produce an optical response proportional to the concentration of the analyte), measure the response and then expel the waste. Consequently the operational lifetime of such sensors in-the-field is limited by stores of reagents and power. To address this problem, *in situ* chemical sensors can use microfluidics (i.e. channel dimensions of 100s of microns) to minimise the amount of sample and reagent and, accordingly, minimise the energy expended on pumping.

Consequently there has been much recent interest in using microfluidics for *in situ* analytical systems.[17–20]

In this brief review we highlight the state of the art of field-deployable microfluidic systems for *in situ* chemical analysis. Using suitable examples we will describe general modes of operation; data that can be obtained; design factors that determine effectiveness; and challenges to wider adoption.

2. *IN SITU* CHEMICAL SENSORS

Many different chemical analytical techniques have been adapted for use in field-deployable systems including colorimetry,[21–44] electrochemistry,[45–47] ultraviolet absorption spectroscopy[15] and chemiluminescence.[48–50] Of these, colorimetry - in which the sample is mixed with an analyte-specific reagent to produce a measurable colour - has proved to be by far the most popular method and has been used for *in situ* analysis of a range of chemical parameters including nitrate and nitrite,[21,22,24,29,31,34,35,38] phosphate,[27,38] iron,[23,26,28,36,39,42–44] manganese,[25,26,28,37,40] sulfide[32,33,35,39,41] silicate[30,32,33,38] and pH.[51–55] Colorimetry lends itself well to microfluidic *in situ* analysers as it is chemically robust, offers excellent analytical performance (limits of detection typically in the order of 10 nM[21,25,36]) and requires relatively small, cheap and easily-sourced components.

A good example is the Mn analyser reported by Statham *et al.*[37,40] described schematically in Fig 1a and shown in Fig 1b. Built in-house using commercially available components, the system operates by continuously pulling water from the environment using a peristaltic pump. The water is then propelled into 800 μm diameter polytetrafluoroethylene (PTFE) tubing along with a flow of reagent consisting of a solution of 1-(2-pyridylazo)-2-naphthol (PAN) mixed with an iron-specific chelating agent to remove any iron interference. The sample and the reagent solution mix in the delay channel (see Fig 1b) and the PAN co-ordinates to the Mn in the sample to produce a coloured product. The reagent solution is formulated such that the PAN is in excess - hence the more Mn in the sample, the more coloured product will form. Having mixed and complexed in the delay channel the solution flows through a spectrophotometer comprising a high-intensity green LED light source and a

silicon photodiode separated by a fluid-filled channel. The spectrophotometer measures the strength of the colour of the solution by the amount of green light that has been absorbed and consequently the amount of Mn present in the sample. In order to accurately calibrate the measurement, the sensor also periodically analyses a blank solution and a standard which are deployed with the sensor. In testing, the sensor showed excellent analytical performance, with a limit of detection (LOD) of 25 nM (as determined from two standard deviations of a series of low concentration measurements).[40]

To demonstrate the utility of the sensor, it was deployed in-the-field to ascertain the distribution of Mn within Loch Etive - a fjord-like deep water basin on the west coast of Scotland (Fig 1c).[37] The sensor was fitted to the autonomous underwater vehicle (AUV) "Autosub" which systematically transected the loch at either fixed depth or fixed height above the seafloor. In doing so, the sensor was able to map the spatial distribution of Mn across depth and location. A plan view of the results obtained from a transect at 80 m depth (Fig 1d) shows how the Mn concentration varied widely from below the detection limit to approximately 700 nM. The highest concentrations were coincident with the entry points of rivers into the loch - suggesting they were the main routes of Mn influx into the local environment. This study demonstrates how even a relatively simple *in situ* sensor, built in-house from commonly available off-the-shelf components, can deliver high quality, spatially detailed and scientifically useful data that would be impossible to obtain using traditional sampling techniques.

3. ENERGY-EFFICIENT SENSORS

A fundamental feature of field-deployed *in situ* sensors is that they will have a finite reserve of electrical power (unless deployed in close proximity to a suitable exterior power source) and so must be designed to be as energy-efficient as possible whilst still maintaining analytical performance. The pump is the major consumer of power within a flow system, and consequently is critical to energy efficiency. Early devices, such as the Mn analyser discussed earlier, all employed peristaltic pumps (in which an electrical rotary motor drives a series of rollers which push fluid along elastic tubing *via* peristalsis, see Fig 2a) to drive the sample and reagents through the device. Small sized peristaltic pumps are easily commercially sourced, relatively cheap and easy to

use and consequently have proved consistently popular.[25,26,28–30,32–35,37,39–43] Nonetheless, peristaltic pumps can suffer from drifting flow rates due to variation in the elasticity and plasticity of the pump tubing with changes in temperatures[35] and, crucially, are relatively power hungry.[56] Consequently, reported deployments of peristaltic pumped sensors have been limited to a day or less, except where power could be externally supplied *via* cabling.[42,43]

In 1994, osmotic pumping was suggested as a solution to reduce power consumption and boost operational longevity. As illustrated in Fig 2b, osmotic pumps utilise the osmotic pressure difference between low and high-salinity reservoirs within the sensor to passively drive very slow flows (typically single $\mu\text{L}/\text{hour}$).[23,31,57] These consume no electrical power during routine sampling and hence increase the longevity of power-critical deployments up to a year.[23] (It should be noted however that traditional, mechanically-driven pumps are still required for administering blank and standard solutions during calibration). While well suited to long stationary deployments in remote locations where the sensor cannot be routinely serviced,[23] osmotic pumping suffers from several key drawbacks: the flow rates drift over time, cannot be arbitrarily set by the user and calibrations can take a very long time (approximately 6 hours) due to the slow flow.[23] Rapid temperature and pressure changes may also cause significant flow rate variation,[31] and even reversal of flow. As a result, reports of osmotically pumped sensors have been rare.[23,31]

An alternative low-power pumping solution was proposed by Weeks *et al.* in 1996[58] and has since been widely used:[24,36,38,56,59] Solenoid pumps use an electromechanically actuated linear piston along with a pair of check valves (Fig 2c) to propel the fluid as a series of discrete pulses (typically tens of μL in volume[38,58,59]). Whilst there are several drawbacks to this method of pumping - the back pressure of the fluidic system needs to be low,[58] and flow rates can drift over time[38] - these are outweighed by the highly significant power savings: Weeks *et al.* showed that four typical solenoid pumps (the minimum number required for a colorimetric sensor) nominally consume $\sim 0.5\text{ W}$ when pumping at the flow rates typically used in a finished device- approximately 1/20 of the power used by the equivalent peristaltic

pumping.[58] In 2004, Okamura *et al.*[56] reported even more pronounced power savings. Replacing peristaltic pumps with solenoid pumps on their *in situ* manganese analyser, they reduced the pumping power consumption to 0.25 W, 1/200[56] of that used before.[49]

4. LOW-POWER SENSORS IN-THE-FIELD

The advent of solenoid pumping, and the associated reduction in sensor power demand, has been important in permitting long-term sensor deployments. A good example of an extended deployment of a standalone solenoid-pumped sensor - and the rich, temporally-detailed data that can be obtained - is the estuarine deployment of an ammonium sensor, “NH₄-Digiscan,” reported by Plant *et al.*[59] The sensor is shown schematically in Fig 3a. Although it uses a different analytical method (electrical conductivity detection rather than colorimetry) it operates on very similar principles to the Mn analyser described previously: The sensor withdraws a continuous stream of water from the environment *via* the solenoid pumps and then injects it into 800 μm diameter tubing along with a buffered basic solution (50 mM sodium hydroxide, 200 mM sodium citrate). The solutions mix in a delay line, raising the pH of the sample. This deprotonates the ammonium ions (NH_4^+) to produce ammonia gas (NH_3) which, once in the diffusion cell, readily diffuses across a teflon membrane into a neighbouring stream of dilute acid (20 μM HCl). The acidic conditions reprotonate the ammonia, converting it to ammonium and trapping it in the acidic stream. The acidic stream then enters a conductivity measurement cell which measures the change in conductivity caused by the change in ionic composition. The ammonium concentration of sampled water is then calculated by comparison with on-board blank and standard solutions. The sensor was found to be highly sensitive with a minimum reported limit of detection of 14 nM.[59]

The NH₄-Digiscan was trialled in several fresh and seawater environments,[59] one of which being Elkhorn slough, a shallow estuary that feeds into Monterey Bay on the coast of California. The sensor was left for four weeks, taking a measurement every hour. As shown in Fig 3b, the high frequency of the *in situ* measurements meant that it could easily resolve the shape and amplitude of the daily NH₄ oscillations that resulted from the composition of the water shifting between nutrient-rich freshwater and nutrient-poor seawater over the

tidal cycle. The daily peak value was seen to rise and fall during the deployment period, attributed to rainfall towards the end of the deployment which caused an increase of nutrient rich freshwater.

Importantly, these results highlight the advantage of *in situ* sampling over a traditional manual sampling program which, in practice, would have a maximum sampling frequency of one measurement per day.[59] As shown in Fig 3b, the choice of sample time would have a huge effect on perceived ammonia variation, for example a maximum of $\sim 5 \mu\text{M}$ would be seen for samples taken at 0630 (round markers) as opposed to $\sim 15 \mu\text{M}$ for samples taken at 1230 (triangular markers). Moreover, manual sampling would yield results lacking any information about the range, shape and frequency of the daily oscillations. With high frequency *in situ* sensing however, we are able to get a highly detailed and accurate picture of the chemical dynamics of the environment.

More recently, syringe pumps have been proposed as an attractive alternative for *in situ* pumping.[21,22] In contrast to solenoid pumps, syringe pumps can deliver pulse-free, stable low-volume flow (down to $\mu\text{L}/\text{min}$) by using a high-torque rotary stepper-motor which linearly drives syringes *via* a screwthread (see Fig 2d). The high torque motor means they can tolerate the elevated backpressures associated with small channels (allowing channel dimensions to be decreased to a couple of hundred μm [21,22,60]) whilst still offering a significant power saving compared to peristaltic pumping. For example the syringe pump used in the example discussed below typically uses 1.5 W during sensor deployment.[22] Consequently they offer optimum flexibility, allowing long term deployments with excellent analytical performance.

An example of an *in situ* sensor that utilises syringe pumping is the colorimetric nitrate/nitrite sensor reported by Beaton *et al.* in 2012,[22] shown in Fig 4a. In contrast to the systems described earlier which used off-the-shelf capillary tubing, microfluidic channels were milled into a plastic substrate and sealed[61] to form a compact monolithic microfluidic chip (“lab on a chip”). The use of syringe pumping meant that small ($150 \times 300 \mu\text{m}$) channels could be used to minimise fluid volume. The pump was directly mounted onto the chip (see Fig 4a) and, importantly, the chip also hosted all optical measurement components.[62] Lab-on-a-chip devices such as this that incorporate multiple

functions into the chip economise on space and as such lend themselves particularly well to miniaturised *in situ* devices. The sensor had a limit of detection of 25 nM, and a linear range up to 350 μ M, making it suitable for operation in a wide range of natural waters.

The sensor was evaluated in-the-field by a twenty six day deployment in Southampton Water, an estuary on the south coast of England that feeds into the English Channel, performing a calibrated measurement (i.e. a sample measurement plus blank and standard) every 20 minutes. A multi-parameter sonde was deployed alongside to record water salinity, pH, and temperature. The nitrate concentration varied from approximately 5 to 190 μ M during the deployment and daily oscillations of up to 40 μ M were observed (see Fig 4b). The daily oscillations are consistent with water composition constantly shifting between (nutrient rich) freshwater and (nutrient poor) seawater during the daily tidal cycle. This is confirmed by comparison with salinity data, where a strong negative correlation was observed (Fig 4c). Of particular interest is how this relationship changed during the deployment. Fig 4c shows for example the nitrate - salinity relation during the four days immediately preceding (blue round markers) and following (red cross markers) a heavy rainfall on day 17 (these time periods are also highlighted in Fig 4b). Following the rainfall, the upper range of the nitrate concentration increased and the salinity notably dropped - consistent with a shift in the freshwater/seawater balance of the estuary caused by an increase in river discharge. At the same time, the gradient of the nitrate-salinity correlation decreased (Fig 4c), consistent with the dilution of the rivers and a corresponding reduction in the nitrate concentration of the freshwater influx.

The highly detailed data obtained during this several-week deployment demonstrates the effectiveness of syringe-pumped sensors. Moreover, the clearly observed shift in nutrient dynamics in response to local weather shows the power of using *in situ* microfluidic sensors to accurately characterise transient perturbations to the local chemical environment.

5. FUTURE

As illustrated by the examples above, *in situ* chemical sensors have been deployed to obtain highly temporally and spatially detailed data to

characterise aquatic environments. Innovations in pumping have increased operational longevity and further development of these sensors is set to continue - yielding cheaper sensors with increased functionality that can be deployed in an expanded range of deployment scenarios.

A key challenge in realising their wide-spread deployment is reducing the cost of each sensor. One way this might happen is through the introduction of high-throughput methods for manufacturing chip-based microfluidics, with embossing or injection moulding being particularly promising routes to scalable and cost effective production.[63,64] Furthermore, cost reduction could be achieved by further optimisation of sensor pumping and valves. Cost analyses show that most of the materials cost of an *in situ* chemical sensor is in its pumps and valves. Significant savings could be made by minimising their use and/or moving to on-chip alternatives based on (for example) electromechanically-actuated integrated membranes.[65,66] As well as encouraging popular uptake, reduction in cost would have the knock-on effect of encouraging the development of sensors for less routinely measured, lower-priority parameters such as heavy metal pollutants (e.g. mercury and arsenic).

If the challenge of low-cost sensors were met, then we could contemplate large scale deployments of networks of *in situ* sensors. This would feasibly allow wide-scale real-time monitoring of rivers and coastal waters for anthropogenic pollution. Importantly, it would also help alleviate the chronic under-sampling of the oceans. Modelling of the biological, chemical, physical and thermodynamic cycles in the ocean depends on experimental measurements. Currently, the oceans are highly under-sampled and the accuracy and reliability of models could be much enhanced by an increase in data supplied by multiple sensors simultaneously deployed in a range of locations.[67]

Any widespread oceanic deployment would likely need to include deployment on low-power underwater profiling vehicles such as oceanic gliders or Argo floats. There have been several reports of microfluidic *in situ* chemical sensors being deployed on underwater vehicles, however, they have so far been limited to deployments on Remotely Operated Vehicles (ROVs)[35,39,50] and AUVs[37,40,48] where power is less critical. The advent of low-power precision pumping, as previously discussed, makes deployment on low-power mobile

platforms feasible and we anticipate that this will be reported in the near future.

Finally we note that low power sensors currently have an optimum temporal resolution in the order of minutes. For long term monitoring this is more than enough, however certain potential applications (e.g. eddy correlation studies or spatially detailed mapping of hydrothermal vents and other geographically small sites) require high frequency measurements. The resolution of the flow-based sensors currently employed are limited by Taylor-Aris dispersion - an effect caused by viscous drag at channel walls which effectively smears chemical composition down the length of the channel.[68] One strategy to address this is to implement multiplexed stop-flow (MSF) architectures.[69] In MSF, dispersion is minimised by removing the long delay channels that are typically used to allow enough time for the sample and reagents to mix before entering the measurement cell. Instead the solutions are inserted into a measurement channel and left to diffusively mix (so called stop-flow operation). This is then repeated in multiple parallel measurement channels in order to increase measurement frequency, with solutions being continuously shuttled into each measurement channel in turn - potentially reducing measurement times to seconds.[69]

While MSF can go a long way to reducing the effect of dispersion, it can be completely removed and sampling frequency dramatically increased by shifting flow regime from continuous phase to droplet flow[70,71] (see Fig 5). In droplet flow microfluidics, an immiscible fluid that preferentially wets the channel walls is added alongside the main analyte stream causing it to break into a succession of discrete sub-microlitre scale droplets. Each droplet is a self-contained, chemically-distinct sample that travels along the fluidic system with a uniform linear velocity and can be individually chemically treated and analysed. As such, droplet flow is ideally suited to high-throughput analytical chemistry, with droplet generation rates routinely at Hz and as high as kHz.[72] A characteristic of droplet flow systems is the small optical pathlengths of the droplets. This would likely preclude most popular colorimetric analytical methods, however numerous fluorescence-based alternatives could be used instead.[73] If employed in a suitably robust *in situ* sensor, the use of droplet flow would be a significant step forward, allowing high frequency, highly

resolved measurements whilst consuming small quantities of sample, reagent and power.

6. CONCLUSION

In summary *in situ* analytical microfluidic systems can give unique and powerful insights into the chemical dynamics of natural waters that would be difficult or impossible to obtain using traditional sampling. The evolution of economical pumping methods have allowed long-term deployments in which daily nutrient fluctuations can be observed with precision and weather-related perturbations to the local environment can be quantified. Several key challenges still remain, however, most importantly the development of low-cost sensors which would encourage widespread uptake of the technology.

With legislators and the general public both becoming increasingly aware of the importance of environmental observation, quantification, management and modelling, it is clear that *in situ* sensors have an important role to play in the measurement of natural waters that will only become more prominent with time.

ACKNOWLEDGEMENTS

This work was funded through the Natural Environment Research Council (NERC) Core budget, the European Commission's Seventh Framework Programme project SenseOCEAN (FP7-CP, grant agreement number: 614141), and the NERC funded DELVE project (NERC grant NE/I008845/1).

Accepted Manuscript

FIGURE CAPTIONS

Figure 1: a) Fluidic schematic of the Mn analyser developed by Statham *et al.*[40] b) Annotated photograph of the analyser out of its housing.[40] c) Map of Scotland with the location of Loch Etive, where the analyser was deployed on an AUV,[37] highlighted by a red square. d) Plan showing the transect path across the loch and the corresponding measured Mn concentrations.[37] The entry points of rivers (the Awe, the Noe and the Liver) into the loch are also shown. Reprinted with permission from P. Statham *et al.*, *Environ. Sci. Technol.* 39 (2005) 9440–9445. Copyright 2005 American Chemical Society.

Figure 2: Cartoons illustrating different methods of pumping for microfluidic systems: a) Peristaltic pumping. b) Osmotic pumping, with pumps for both infusion and withdrawal shown. c) Solenoid pumping. d) Syringe pumping.

Figure 3: a) Schematic of the “NH₄-Digiscan” ammonium sensor developed by Plant *et al.*[59] b) Ammonium levels recorded by NH₄-Digiscan during a one month deployment in Elkhorn Slough, a shallow estuary on the coast of California.[59] Measurements are shown as grey round markers, while the black round and black triangular markers highlight the perceived change in ammonium if measurements were restricted to one sample per day (as might be expected for traditional sampling) at 06:30 or 12:00 respectively. Adapted with permission from J.N. Plant *et al.*, *Limnol. Oceanogr. Methods.* 7 (2009) 144–156. Copyright 2009 Association for the Sciences of Limnology and Oceanography, Inc.

Figure 4: a) Annotated photograph showing the nitrate sensor developed by Beaton *et al.*[22] b) Nutrient data obtained *in situ* by the nitrate sensor during deployment in Southampton Water, an estuary on the south coast of England, over the course of 26 days. Manually obtained and analysed samples (“bottle

samples”) are shown by red crosses. The four day periods immediately preceding (blue) and after (red) a heavy rain event are highlighted.[22] c) Mixing diagram showing the relationship between nitrate and salinity in the estuary. A negative correlation between nitrate and salinity was observed (consistent with the shift between nutrient-rich freshwater and nutrient-poor seawater) and a notable shift is seen when comparing data obtained in the four days before (blue round markers) and after (red cross markers) a heavy rain event. The data corresponds to the coloured areas highlighted in (b).

Figure 5: Cartoons showing a) Laminar flow of a single continuous phase. The arrows indicate the fluid’s linear velocity, with viscous drag slowing flow at the channel walls. b) Droplet flow caused by the introduction of an immiscible fluid that preferentially wets the channel walls. Each droplet flows with a uniform velocity.

BIOGRAPHIES

Dr Adrian M. Nightingale is a research fellow in droplet microfluidics and point-of-care diagnostics at the University of Southampton. He received his PhD in microfluidic reactor technology from Imperial College London and currently researches the use of microfluidics for field-deployable analytical systems.

Dr. Alexander D. Beaton is a research technologist in the Ocean Technology and Engineering Group at the National Oceanography Centre, Southampton. He received his Master degree in physics from the University of Exeter, and his PhD in glaciology from the University of Bristol. His current research focuses on developing and optimising the next generation of miniaturised *in situ* chemical analysers for range of natural waters, including the oceans.

Dr. Matthew C. Mowlem is the head of the Ocean Technology and Engineering Group at the National Oceanography Centre and co-PI at the Centre for Marine Micro Systems (a collaboration between NOC and University of Southampton). His research focuses on the creation of the next generation of submersible and robust sensing systems for marine and environmental applications. This includes the development of miniaturised and mass producible sensors for high performance metrology of oceanic chemistry and microbiology, and submersible probe technologies for the exploration and characterisation of subglacial lake environments.

- [1] S. Dutkiewicz, M.J. Follows, P. Parekh, Interactions of the iron and phosphorus cycles: A three-dimensional model study, *Global Biogeochem. Cycles*. 19 (2005). doi:10.1029/2004gb002342.
- [2] K.J. Flynn, A mechanistic model for describing dynamic multi-nutrient, light, temperature interactions in phytoplankton, *J. Plankton Res.* 23 (2001) 977–997.
- [3] J.K. Moore, S.C. Doney, J.A. Kleypas, D.M. Glover, I.Y. Fung, An intermediate complexity marine ecosystem model for the global domain, *Deep-sea. Res. II*. 49 (2002) 403–462.
- [4] J.K. Moore, S.C. Doney, K. Lindsay, Upper ocean ecosystem dynamics and iron cycling in a global three-dimensional model, *Global Biogeochem. Cycles*. 18 (2004). doi:10.1029/2004gb002220.
- [5] A. Yool, E.E. Popova, T.R. Anderson, MEDUSA-2.0: an intermediate complexity biogeochemical model of the marine carbon cycle for climate change and ocean acidification studies, *Geosci. Model Dev.* 6 (2013) 1767–1811.
- [6] L. Brüggemann, K. Kremling, Sampling, in: *Methods Seawater Anal.*, Wiley-VCH Verlag GmbH, 2007: pp. 1–25.
- [7] T.R. Martz, J.G. Connery, K.S. Johnson, Testing the Honeywell Durafet for seawater pH applications, *Limnol. Oceanogr. Methods*. 8 (2010) 172–184.
- [8] Y. Takeshita, T.R. Martz, K.S. Johnson, A.G. Dickson, Characterization of an Ion Sensitive Field Effect Transistor and Chloride Ion Selective Electrodes for pH Measurements in Seawater, *Anal. Chem.* 86 (2014) 22, 11189–11195.
- [9] N.P. Revsbech, An oxygen microsensor with a guard cathode, *Limnol. Oceanogr.* 34 (1989) 474–478.
- [10] I. Klimant, V. Meyer, M. Kühl, Fiber-optic oxygen microsensors, a new tool in aquatic biology, *Limnol. Oceanogr.* 40 (1995) 1159–1165.
- [11] P. Fietzek, S. Kramer, D. Esser, Deployments of the HydroC™ (CO₂/CH₄) on stationary and mobile platforms – Merging trends in the field of platform and sensor development, in: *Ocean. 2011*, 2011.

- [12] G. Neurauter, I. Klimant, O.S. Wolfbeis, Fiber-optic microsensor for high resolution pCO₂ sensing in marine environment, *Fresenius. J. Anal. Chem.* 366 (2000) 481–487.
- [13] K.S. Johnson, L.J. Coletti, F.P. Chavez, Diel nitrate cycles observed with in situ sensors predict monthly and annual new production, *Deep-sea Res. I.* 53 (2006) 561–573. doi:10.1016/j.dsr.2005.12.004.
- [14] K.S. Johnson, S.C. Riser, D.M. Karl, Nitrate supply from deep to near-surface waters of the North Pacific subtropical gyre., *Nature.* 465 (2010) 1062–5.
- [15] K.S. Johnson, L.J. Coletti, In situ ultraviolet spectrophotometry for high resolution and long-term monitoring of nitrate, bromide and bisulfide in the ocean, *Deep-sea Res. I.* 49 (2002) 1291–1305.
- [16] M.S. Finch, D.J. Hydes, C.H. Clayson, J. Dakin, P. Gwilliam, A low power ultra violet spectrophotometer for measurement of nitrate in seawater: introduction, calibration and initial sea trials, *Anal. Chim. Acta.* 377 (1998) 167–177.
- [17] G. Mills, G. Fones, A review of in situ methods and sensors for monitoring the marine environment, *Sens. Rev.* 32 (2012) 17–28.
- [18] C.D.M. Campos, J.A. F. da Silva, Applications of autonomous microfluidic systems in environmental monitoring, *RSC Adv.* 3 (2013) 18216.
- [19] A. Jang, Z. Zou, K.K. Lee, C.H. Ahn, P.L. Bishop, State-of-the-art lab chip sensors for environmental water monitoring, *Meas. Sci. Technol.* 22 (2011) 032001.
- [20] J.C. Jokerst, J.M. Emory, C.S. Henry, Advances in microfluidics for environmental analysis., *Analyst.* 137 (2012) 24–34.
- [21] A.D. Beaton, V.J. Sieben, C.F. a. Floquet, E.M. Waugh, S. Abi Kaed Bey, I.R.G. Ogilvie, et al., An automated microfluidic colourimetric sensor applied in situ to determine nitrite concentration, *Sensor Actuat B-Chem.* 156 (2011) 1009–1014.
- [22] A.D. Beaton, C.L. Cardwell, R.S. Thomas, V.J. Sieben, F.-E. Legiret, E.M. Waugh, et al., Lab-on-chip measurement of nitrate and nitrite for in situ analysis of natural waters., *Environ. Sci. Technol.* 46 (2012) 9548–56.

- [23] T.P. Chapin, H.W. Jannasch, K.S. Johnson, In situ osmotic analyzer for the year-long continuous determination of Fe in hydrothermal systems, *Anal. Chim. Acta.* 463 (2002) 265–274.
- [24] T. Chapin, J. Caffrey, H. Jannasch, L.J. Coletti, J. Haskins, K. Johnson, Nitrate sources and sinks in Elkhorn Slough, California: results from long-term continuous in situ nitrate analyzers, *Estuaries.* 27 (2004) 882–894.
- [25] C.S. Chin, K.S. Johnson, K.H. Coale, Spectrophotometric determination of dissolved manganese in natural waters with 1-(2-pyridylazo)-2-naphthol: application to analysis in situ in hydrothermal plumes, *Mar. Chem.* 37 (1992) 65–82.
- [26] C. Chin, K. Coale, V. Elrod, K. Johnson, In situ observations of dissolved iron and manganese in hydrothermal vent plumes, Juan de Fuca Ridge, *J. Geophys. Res.* 99 (1994) 4969–4984.
- [27] J. Cleary, D. Maher, C. Slater, D. Diamond, In situ monitoring of environmental water quality using an autonomous microfluidic sensor, *2010 IEEE Sensors Appl. Symp.* (2010) 36 – 40.
- [28] K. Coale, C. Chin, G. Massoth, K. Johnson, E. Baker, In situ chemical mapping of dissolved iron and manganese in hydrothermal plumes, *Nature.* 352 (1991) 325 – 328.
- [29] A. David, T. McCormack, A. Morris, P. Worsfold, A submersible flow injection-based sensor for the determination of total oxidised nitrogen in coastal waters, *Anal. Chim. Acta.* 361 (1998) 63–72.
- [30] J. Floch, S. Blain, D. Birot, P. Treguer, In situ determination of silicic acid in sea water based on FIA and colorimetric dual-wavelength measurements., *Anal. Chim. Acta.* 377 (1998) 157–166.
- [31] H. Jannasch, K. Johnson, C. Sakamoto, Submersible, osmotically pumped analyzer for continuous determination of nitrate in situ, *Anal. Chem.* 66 (1994) 3352–3361.
- [32] K. Johnson, C. Beehler, C. Sakamoto-Arnold, A submersible flow analysis system, *Anal. Chim. Acta.* 179 (1986) 245–257.

- [33] K. Johnson, C. Beehler, C. Sakamoto-Arnold, J. Childress, In situ measurements of chemical distributions in a deep-sea hydrothermal vent field, *Science*. 231 (1986) 1139–1141.
- [34] K. Johnson, C. Sakamoto-Arnold, C. Beehler, Continuous determination of nitrate concentrations in situ, *Deep. Res.* 36 (1989) 1407–1413.
- [35] N. Le Bris, P.-M. Sarradin, D. Birot, a.-M. Alayse-Danet, A new chemical analyzer for in situ measurement of nitrate and total sulfide over hydrothermal vent biological communities, *Mar. Chem.* 72 (2000) 1–15.
- [36] D. Meyer, R.D. Prien, O. Dellwig, D.P. Connelly, D.E. Schulz-Bull, In situ determination of iron(II) in the anoxic zone of the central Baltic Sea using ferene as spectrophotometric reagent, *Mar. Chem.* 130-131 (2012) 21–27.
- [37] P. Statham, D. Connelly, C. German, T. Brand, J. Overnell, E. Bulukin, et al., Spatially complex distribution of dissolved manganese in a fjord as revealed by high-resolution in situ sensing using the autonomous underwater vehicle autosub, *Environ. Sci. Technol.* 39 (2005) 9440–9445.
- [38] D. Thouron, R. Vuillemin, X. Philippon, A. Lourenco, C. Provost, A. Cruzado, et al., An autonomous nutrient analyzer for oceanic long-term in situ biogeochemical monitoring, *Anal. Chem.* 75 (2003) 2601–2609.
- [39] R. Vuillemin, D. Le Roux, P. Dorval, K. Bucas, J.P. Sudreau, M. Hamon, et al., CHEMINI: A new in situ CHEMical MINIaturized analyzer, *Deep Sea Res. Part I Oceanogr. Res. Pap.* 56 (2009) 1391–1399.
- [40] P.J. Statham, D.P. Connelly, C.R. German, E. Bulukin, N. Millard, S. McPhail, et al., Mapping the 3D spatial distribution of dissolved manganese in coastal waters using an in situ analyser and the autonomous underwater vehicle Autosub, *Underw. Technol.* 25 (2003) 129–134.
- [41] C. Sakamoto-Arnold, K. Johnson, C. Beehler, Determination of hydrogen sulfide in seawater using flow injection analysis and flow analysis, *Limnol. Oceanogr.* 31 (1986) 894–900.
- [42] D. Cuvelier, P. Legendre, A. Laes, P.-M. Sarradin, J. Sarrazin, Rhythms and community dynamics of a hydrothermal tubeworm assemblage at main

- endeavour field - a multidisciplinary deep-sea observatory approach., *PLoS One*. 9 (2014) e96924.
- [43] J. Sarrazin, D. Cuvelier, L. Peton, P. Legendre, P.M. Sarradin, High-resolution dynamics of a deep-sea hydrothermal mussel assemblage monitored by the EMSO-Açores MoMAR observatory, *Deep-sea Res. I*. 90 (2014) 62–75.
- [44] A. Milani, P.J. Statham, M.C. Mowlem, D.P. Connelly, Development and application of a microfluidic in-situ analyzer for dissolved Fe and Mn in natural waters, *Talanta*. 136 (2015) 15–22.
- [45] K.M. Mullaugh, G.W. Luther, S. Ma, T.S. Moore, M. Yücel, E.L. Becker, et al., Voltammetric (Micro)Electrodes for the In Situ Study of Fe²⁺ Oxidation Kinetics in Hot Springs and S₂O Production at Hydrothermal Vents, *Electroanalysis*. 20 (2008) 280–290.
- [46] F.U. Zielinski, H.-H. Gennerich, C. Borowski, F. Wenzhöfer, N. Dubilier, In situ measurements of hydrogen sulfide, oxygen, and temperature in diffuse fluids of an ultramafic-hosted hydrothermal vent field (Logatchev, 14°45'N, Mid-Atlantic Ridge): Implications for chemosymbiotic bathymodiolin mussels, *Geochemistry, Geophys. Geosystems*. 12 (2011) doi:10.1029/2011GC003632.
- [47] L. Contreira-Pereira, M. Yücel, D. Omanovic, J.-P. Brulport, N. Le Bris, Compact autonomous voltammetric sensor for sulfide monitoring in deep sea vent habitats, *Deep-sea Res. I*. 80 (2013) 47–57.
- [48] T. Doi, M. Takano, K. Okamura, T. Ura, T. Gamo, In-situ survey of nanomolar manganese in seawater using an autonomous underwater vehicle around a volcanic crater at Teishi Knoll, Sagami Bay, Japan, *J. Oceanogr.* 64 (2008). doi: 10.1029/93JB02036
- [49] K. Okamura, H. Kimoto, K. Saeki, J. Ishibashi, H. Obata, M. Maruo, et al., Development of a deep-sea in situ Mn analyzer and its application for hydrothermal plume observation, *Mar. Chem.* 76 (2001) 17–26.
- [50] C. Provin, T. Fukuba, K. Okamura, T. Fujii, An integrated microfluidic system for manganese anomaly detection based on chemiluminescence: description and practical use to discover hydrothermal plumes near, *IEEE J. Ocean. Eng.* 38 (2013) 178–185.

- [51] X. Liu, Z.A. Wang, R.H. Byrne, E. a. Kaltenbacher, R.E. Bernstein, Spectrophotometric Measurements of pH in-Situ: Laboratory and Field Evaluations of Instrumental Performance, *Environ. Sci. Technol.* 40 (2006) 5036–5044.
- [52] Y. Nakano, H. Kimoto, S. Watanabe, K. Harada, Y.W. Watanabe, Simultaneous vertical measurements of in situ pH and CO₂ in the sea using spectrophotometric profilers, *J. Oceanogr.* 62 (2006) 71–81.
- [53] M.P. Seidel, M.D. DeGrandpre, A.G. Dickson, A sensor for in situ indicator-based measurements of seawater pH, *Mar. Chem.* 109 (2008) 18–28.
- [54] V.M.C. Rérolle, C.F. a Floquet, A.J.K. Harris, M.C. Mowlem, R.R.G.J. Bellerby, E.P. Achterberg, Development of a colorimetric microfluidic pH sensor for autonomous seawater measurements., *Anal. Chim. Acta.* 786 (2013) 124–31.
- [55] T.R. Martz, J.J. Carr, C.R. French, M.D. DeGrandpre, A Submersible Autonomous Sensor for Spectrophotometric pH Measurements of Natural Waters, *Anal. Chem.* 75 (2003) 1844–1850.
- [56] K. Okamura, H. Hatanaka, H. Kimoto, M. Suzuki, Y. Sohrin, E. Nakayama, et al., Development of an in situ manganese analyzer using micro-diaphragm pumps and its application to time-series observations in a hydrothermal field at the Suiyo seamount, *Geochem. J.* 38 (2004) 635–642.
- [57] H.W. Jannasch, C.G. Wheat, J. Plant, M. Kastner, D. Stakes, Continuous chemical monitoring with osmotically pumped water samplers: OsmoSampler design and applications, *Limnol. Oceanogr. Methods.* 2 (2004) 102–113.
- [58] D.A. Weeks, K.S. Johnson, Solenoid pumps for flow injection analysis., *Anal. Chem.* 68 (1996) 2717–9.
- [59] J.N. Plant, K.S. Johnson, J.A. Needoba, L.J. Coletti, NH₄-Digiscan : an in situ and laboratory ammonium analyzer for estuarine , coastal , and shelf waters, *Limnol. Oceanogr. Methods.* 7 (2009) 144–156.
- [60] F.-E. Legiret, V.J. Sieben, E.M.S. Woodward, S.K. Abi Kaed Bey, M.C. Mowlem, D.P. Connelly, et al., A high performance microfluidic analyser

- for phosphate measurements in marine waters using the vanadomolybdate method., *Talanta*. 116 (2013) 382–7.
- [61] I.R.G. Ogilvie, V.J. Sieben, C.F.A. Floquet, R. Zmijan, M.C. Mowlem, H. Morgan, Reduction of surface roughness for optical quality microfluidic devices in PMMA and COC, *J. Micromech. Microeng.* 20 (2010) 065016
- [62] V.J. Sieben, C.F. a. Floquet, I.R.G. Ogilvie, M.C. Mowlem, H. Morgan, Microfluidic colourimetric chemical analysis system: Application to nitrite detection, *Anal. Methods*. 2 (2010) 484.
- [63] J. Narasimhan, I. Papautsky, Polymer embossing tools for rapid prototyping of plastic microfluidic devices, *J. Micromech. Microeng.* 14 (2004) 96–103.
- [64] G. Lee, S. Chen, G. Huang, W. Sung, Y. Lin, Microfabricated plastic chips by hot embossing methods and their applications for DNA separation and detection, *Sensor. Actuat. B-Chem.* 75 (2001) 142–148.
- [65] K.W. Oh, C.H. Ahn, A review of microvalves, *J. Micromech. Microeng.* 16 (2006) R13–R39.
- [66] M.A. Unger, H. Chou, T. Thorsen, A. Scherer, S.R. Quake, Monolithic Microfabricated Valves and Pumps by Multilayer Soft Lithography, *Science*. 288 (2000) 113–116.
- [67] J. Hart, K. Martinez, Environmental Sensor Networks: A revolution in the earth system science?, *Earth-Science Rev.* 78 (2006) 177–191.
- [68] A.M. Nightingale, J.C. de Mello, Microscale synthesis of quantum dots, *J. Mater. Chem.* 20 (2010) 8454.
- [69] I.R.G. Ogilvie, V.J. Sieben, M.C. Mowlem, H. Morgan, Temporal optimization of microfluidic colorimetric sensors by use of multiplexed stop-flow architecture., *Anal. Chem.* 83 (2011) 4814–21.
- [70] A.M. Nightingale, J.C. deMello, Segmented flow reactors for nanocrystal synthesis, *Adv. Mater.* 25 (2013) 1813–1821.
- [71] H. Song, D.L. Chen, R.F. Ismagilov, Reactions in droplets in microfluidic channels., *Angew. Chem. Int. Ed. Engl.* 45 (2006) 7336–56.

- [72] A. Huebner, S. Sharma, M. Srisa-Art, F. Hollfelder, J.B. Edel, A.J. Demello, Microdroplets: a sea of applications?, *Lab Chip*. 8 (2008) 1244–54.
- [73] X. Wang, J. Lin, M. Liu, X. Cheng, Flow-based luminescence-sensing methods for environmental water analysis, *TrAC Trends Anal. Chem.* 28 (2009) 75–87.

Accepted Manuscript

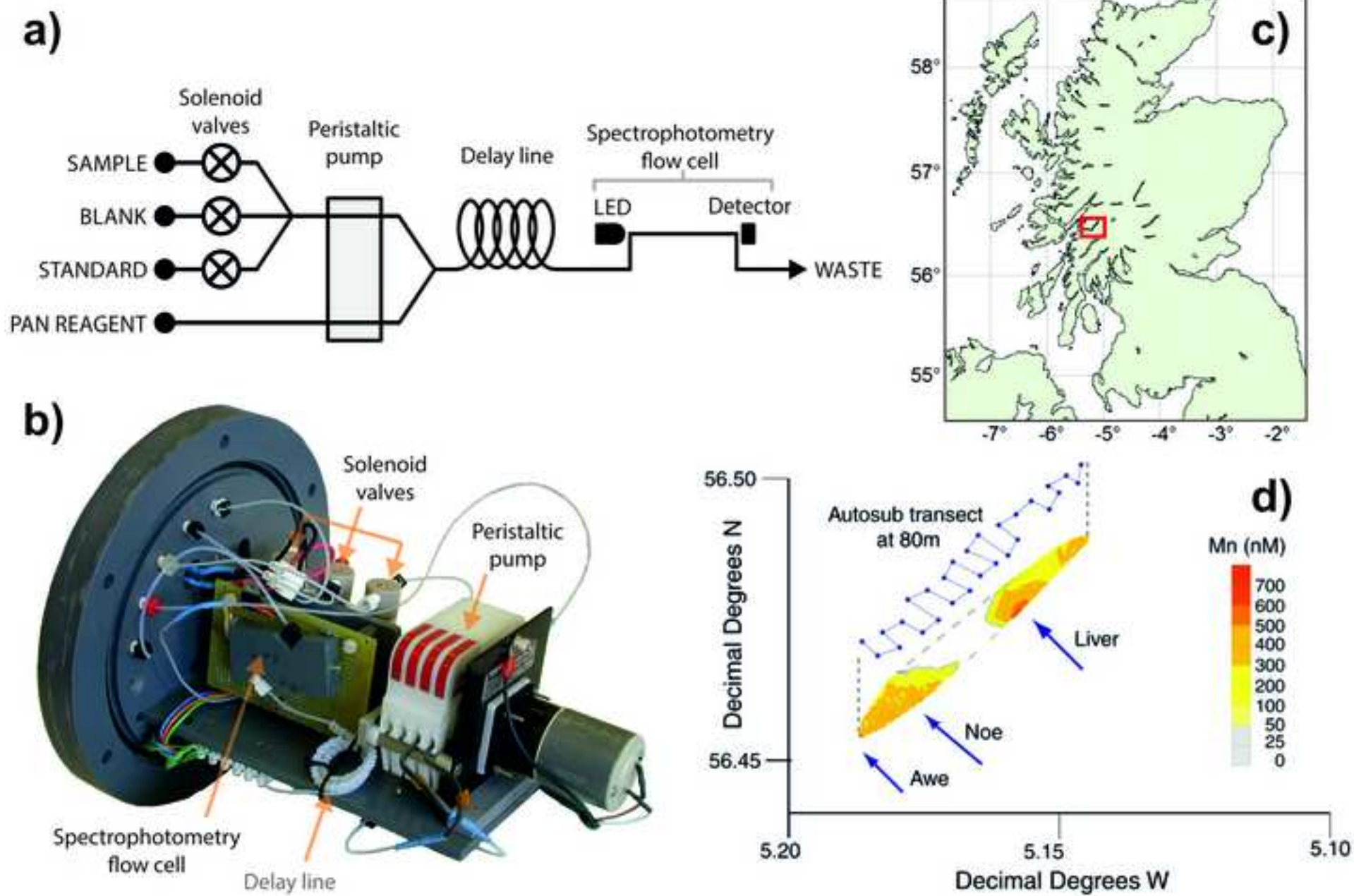

a) Peristaltic pump

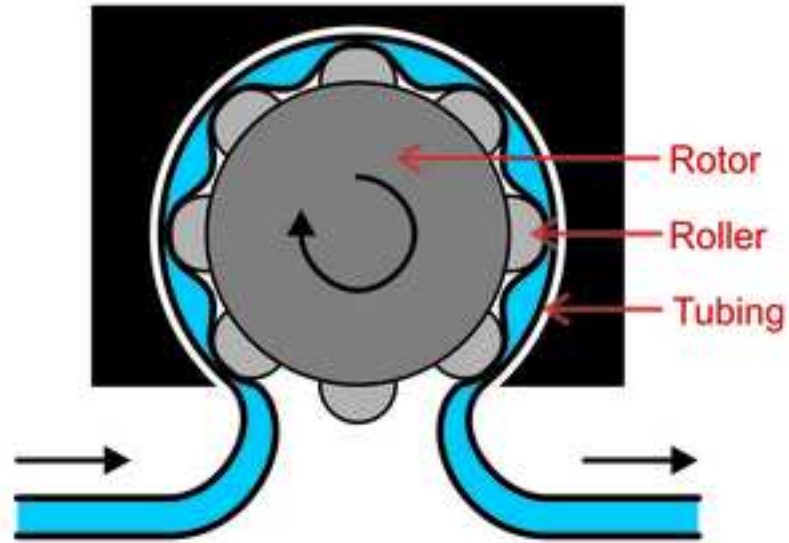

b) Solenoid pump

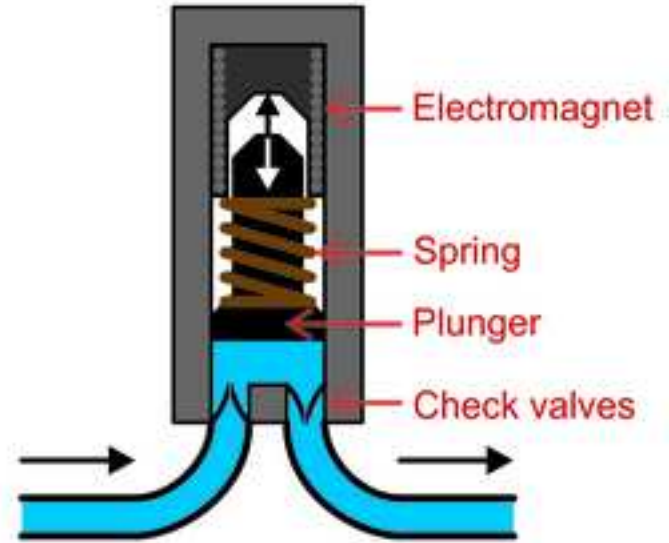

c) Syringe pump

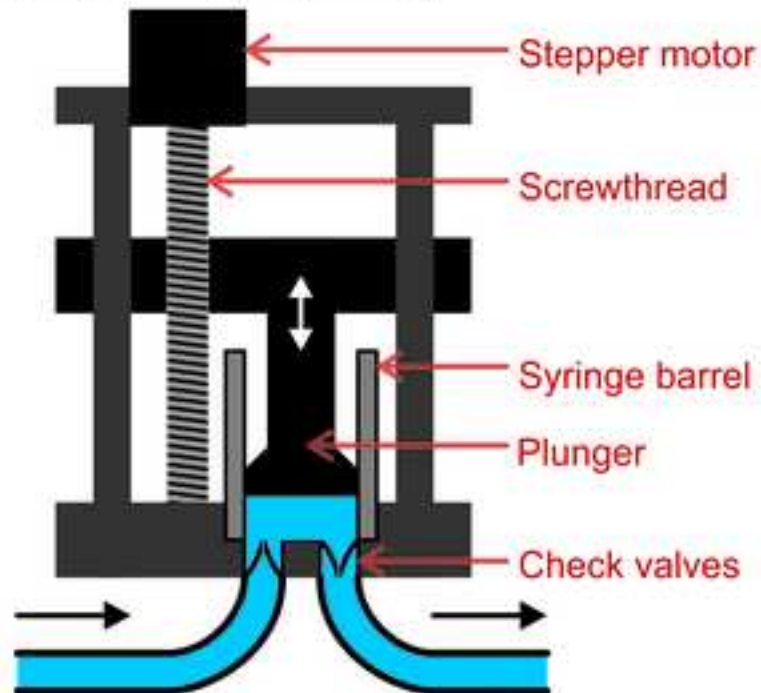

d) Osmotic pumps

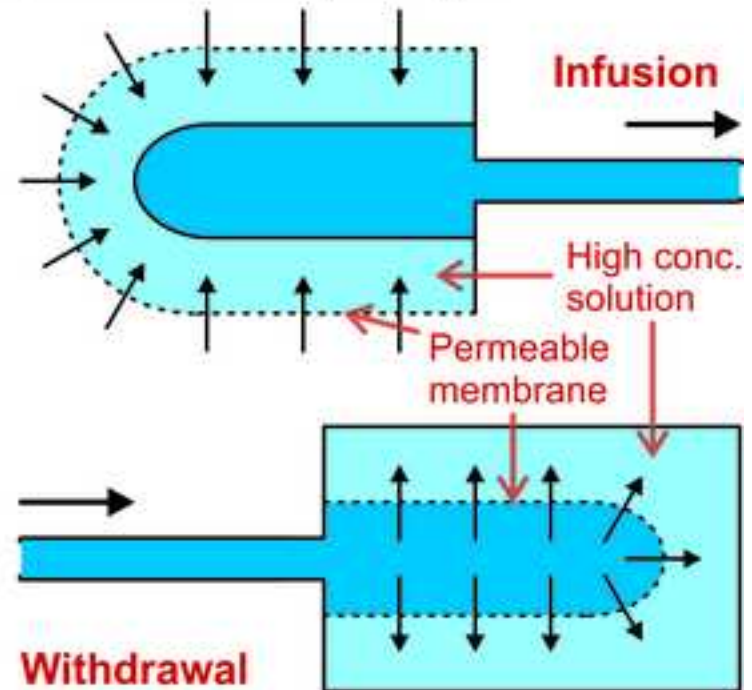

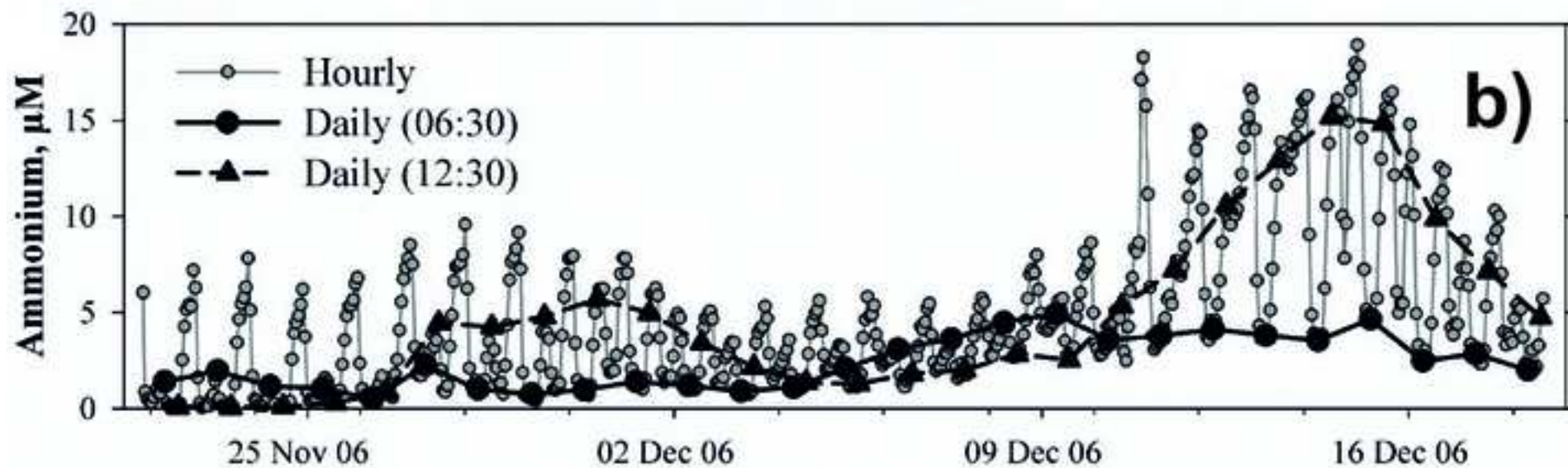
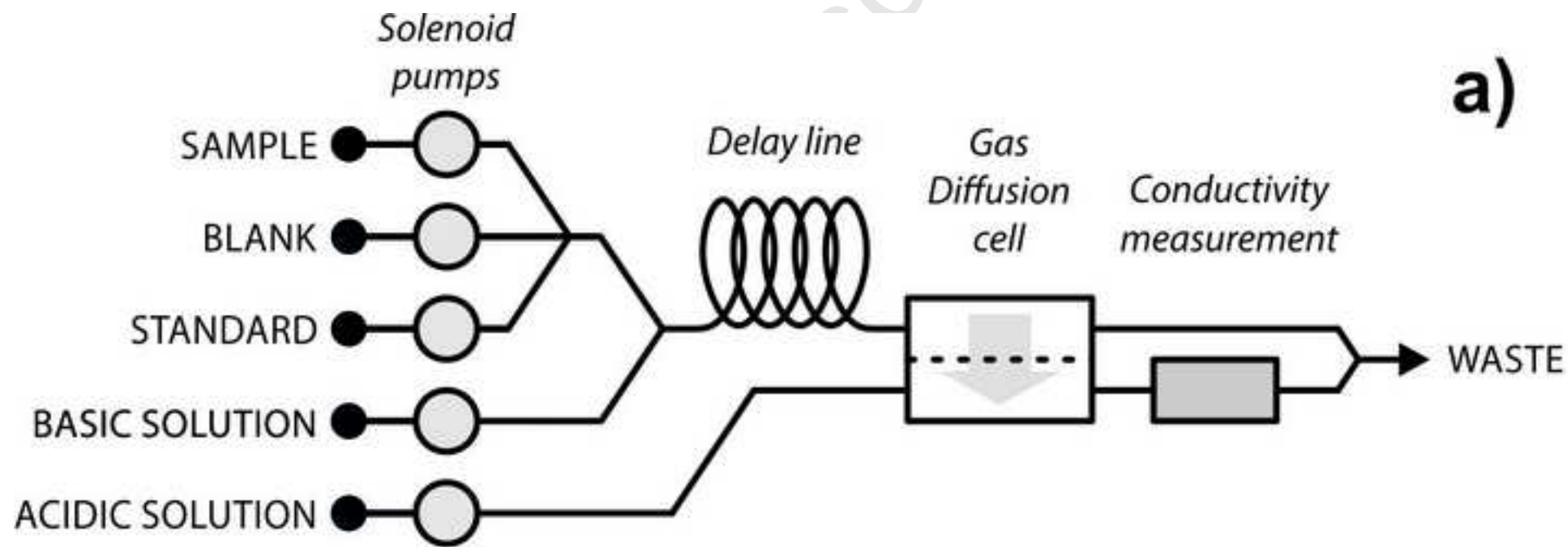

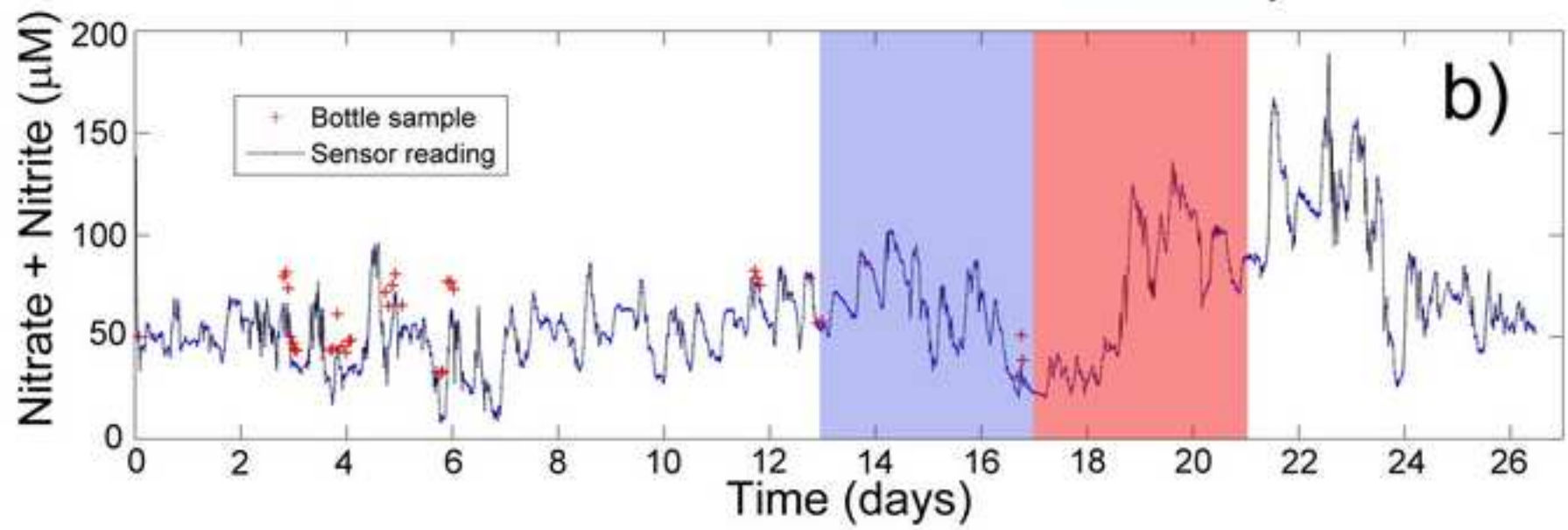
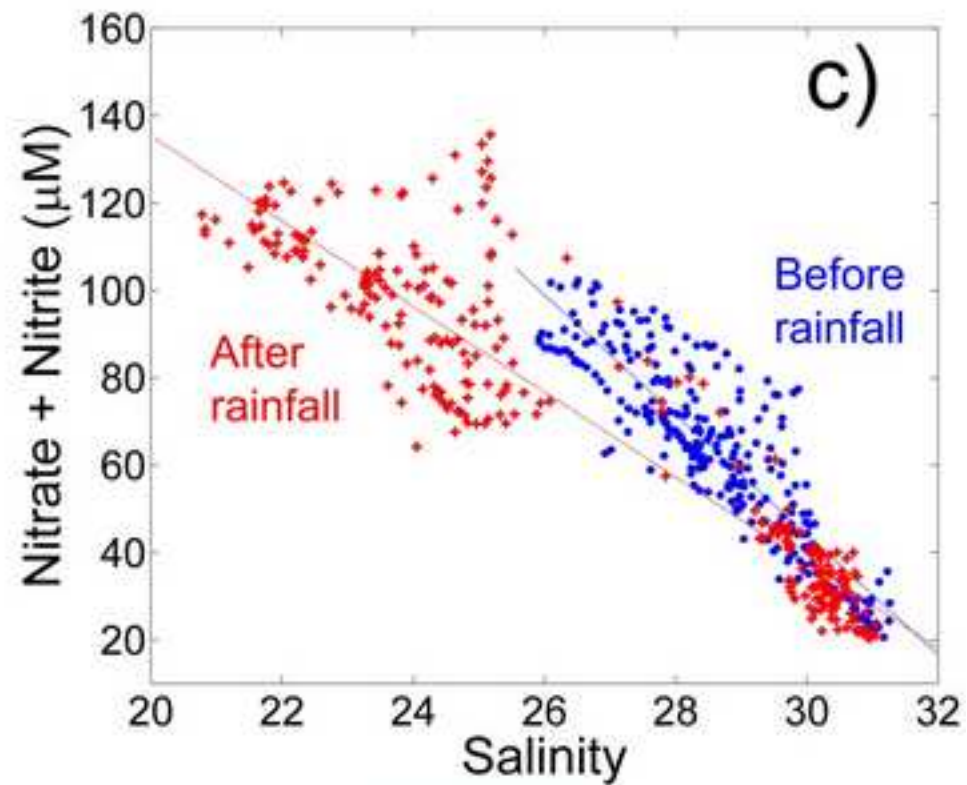
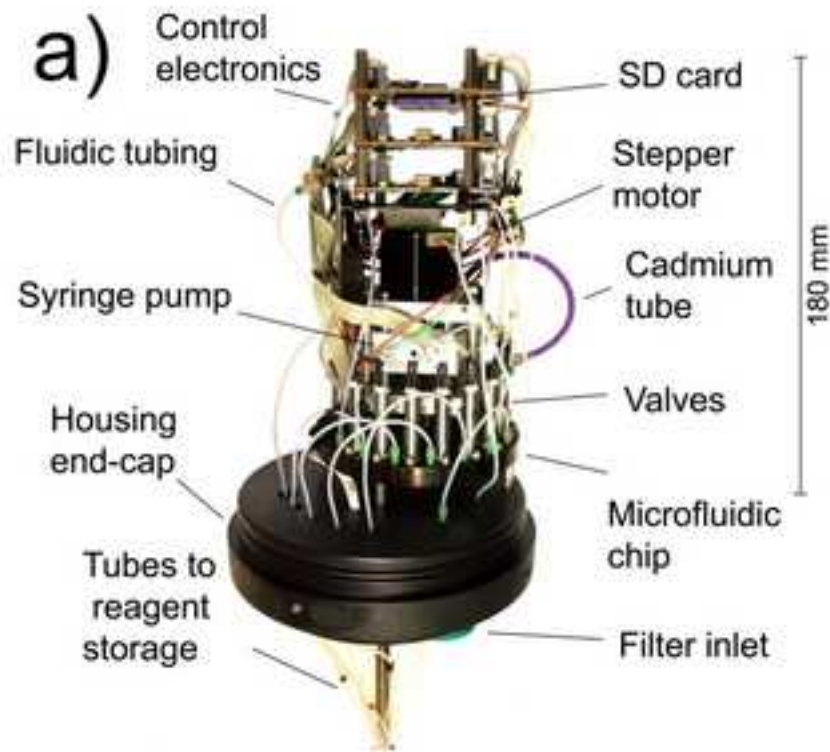

Manuscript

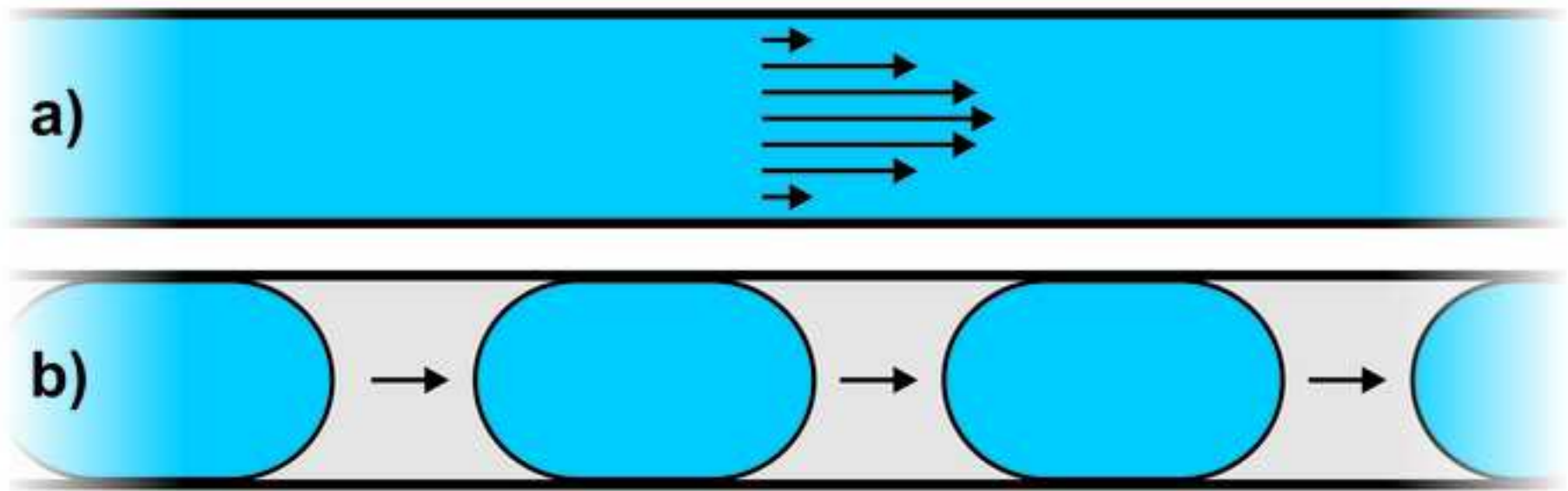

Dr Adrian M. Nightingale is a research fellow in droplet microfluidics and point-of-care diagnostics at the University of Southampton. He received his PhD in microfluidic reactor technology from Imperial College London and currently develops microfluidic technology for field-deployable analytical systems.

Dr. Alexander D. Beaton is a research technologist in the Ocean Technology and Engineering Group at the National Oceanography Centre, Southampton. He received his Master degree in physics from the University of Exeter, and his PhD in glaciology from the University of Bristol. His current research focuses on developing and optimising the next generation of miniaturised in situ chemical analysers for range of natural waters, including the oceans.

Dr. Matthew C. Mowlem is the head of the Ocean Technology and Engineering Group at the National Oceanography Centre and co-PI at the Centre for Marine Micro Systems (a collaboration between NOC and University of Southampton). His research focuses on the creation of the next generation of submersible and robust sensing systems for marine and environmental applications. This includes the development of miniaturised and mass producible sensors for high performance metrology of oceanic chemistry and microbiology, and submersible probe technologies for the exploration and characterisation of subglacial lake environments.

Accepted Manuscript