

Bio-inspired optimization of fuzzy control system for inspection robotic platform: comparative analysis of hybrid swarm methods

Yuriy Kondratenko^{1,2,†}, Oleksiy Kozlov^{1,*}, Yue Zheng^{3,†}, Jianjun Wang^{4,†}, Vitalii Kuzmenko^{5,†} and Anna Aleksieieva^{1,†}

¹ Petro Mohyla Black Sea National University, 10 68th Desantnykiv st., Mykolaiv, 54003, Ukraine

² Institute of Artificial Intelligence Problems of MES and NAS of Ukraine, 11/5 Mala Zhytomyrska st., Kyiv, 01001, Ukraine

³ Yancheng Polytechnic College, No. 285, South Jiefang Road, Yancheng, Jiangsu Province, 224005, China

⁴ Yunzhou Innovation Technology Co.Ltd, Yancheng, Jiangsu Province, 224005, China

⁵ Naval Institute of National University "Odessa Maritime Academy", 8 Diedrichson st., Odesa, 65029, Ukraine

Abstract

The focus of this paper is to address research issues and conduct a comparative analysis of swarm bio-inspired methods for optimizing parameters in fuzzy systems (FS). Various hybrid modifications of particle swarm optimization (PSO) and grey wolf optimization (GWO) multi-agent techniques, tailored for FS parameter optimization, are compared with conventional search methods. The research and comparative analysis are performed using a specific example: the parametric optimization of a Takagi-Sugeno fuzzy control system designed for an inspection mobile robotic platform (MRP). This robotic platform is capable of navigating inclined and vertical surfaces. It serves as an efficient autonomous tool for executing complex inspection and monitoring tasks in challenging and hazardous environments in various industrial facilities and urban environments inaccessible to humans. However, to effectively utilize this MRP, an intelligent control system optimized through an advanced method is necessary. The simulation results obtained validate the effectiveness of the presented swarm bio-inspired optimization techniques, considering both the performance achieved by the FS and the computational costs incurred.

Keywords

Fuzzy control system, bio-inspired optimization, hybrid swarm methods, particle swarm optimization, grey wolf optimization, inspection mobile robotic platform

1. Introduction

When developing complex systems and models across various domains such as technology, manufacturing, economics, agriculture, and medicine, the need for optimal solutions finding

MoMLet-2024: 6th International Workshop on Modern Machine Learning Technologies, May, 31 - June, 1, 2024, Lviv-Shatsk, Ukraine

* Corresponding author.

† These authors contributed equally.

✉ y_kondrat2002@yahoo.com (Y. Kondratenko); kozlov_ov@ukr.net (O. Kozlov); and_bsb@126.com (Y. Zheng); jianjun.wang@yunzhou-tech.com (J. Wang); v86651984@gmail.com (V. Kuzmenko); anna.aleksyeyeva@chmnu.edu.ua (A. Aleksieieva)

ORCID: 0000-0001-7736-883X (Y. Kondratenko); 0000-0003-2069-5578 (O. Kozlov); 0000-0003-4690-098X (Y. Zheng); 0009-0000-8417-4099 (J. Wang); 0000-0001-8064-0726 (V. Kuzmenko); 0000-0003-0345-8538 (A. Aleksieieva)



© 2024 Copyright for this paper by its authors. Use permitted under Creative Commons License Attribution 4.0 International (CC BY 4.0).

in a multidimensional search space often arises [1-4]. Conventional optimization methods frequently prove ineffective for solving these challenges due to the terrain uncertainty and the presence of multi-extremality in the functions under study, which describe the complex dependencies of solution effectiveness on unknown parameters [5-7]. Presently, approximate global optimization methods are becoming increasingly popular due to their ability to uncover high-quality solutions with acceptable computational and time expenses [8, 9]. Among these methods, bioinspired swarm and evolutionary optimization algorithms show promise [10-13]. Unlike traditional local search methods, bioinspired techniques can be utilized even in situations where there is scarce information about the nature and specific characteristics of the objects and processes being studied. They excel at avoiding local minima and can be readily adapted to address a wide range of real-world optimization tasks. Furthermore, these methods employ relatively simple computational procedures that emulate behaviors observed in social animals, evolutionary principles like natural selection, and physical phenomena. Ultimately, bioinspired intelligent techniques can be seamlessly integrated with various local search algorithms, thereby enhancing the optimization process significantly by strategically combining global and local search strategies [14].

Among the array of bioinspired intelligent methods under consideration, those that have emerged as particularly effective and widely adopted for solving diverse optimization problems in recent years, include grey wolf optimization (GWO) [15], cuckoo search (CS) algorithm [16], ant lion optimization (ALO) [17], particle swarm optimization (PSO) [18], firefly algorithm (FA) [19], chaotic swarming of particles (CSP) algorithm [20], whale optimization algorithm (WOA) [21], and numerous others. Additionally, various hybrid methods have been successfully employed for the development of various complex systems [22].

The application of bioinspired swarm and evolutionary techniques in designing and optimizing intelligent control and decision support systems across various fields is a promising area, especially when applied to fuzzy logic systems [23, 24]. Recent studies highlight that fuzzy systems developed using bioinspired optimization methods demonstrate significant efficacy in addressing complex control and decision support challenges across diverse domains [11, 13, 25]. So, for example, in studies [26-29] PSO methods are adapted for parametric optimization of linguistic terms (LT) of fuzzy automatic control systems (ACS) of various technical plants. In particular, in [28], the optimization of the vertices of triangular-type LTs is performed for a fuzzy power control system of an industrial wireless sensor network. In the paper [27], optimization of the parameters of 1st type Gaussian LTs for the fuzzy ACS of the autonomous mobile robot operating in an uncertain environment was carried out. Furthermore, the GWO method demonstrates highly competitive performance in addressing the challenges of parametric optimization across a range of configurations and purposes for fuzzy systems, surpassing other well-established bioinspired techniques [30, 31]. Consequently, research directed towards the development, refinement, and deployment of bioinspired swarm methods and approaches for synthesizing and optimizing various types of fuzzy systems remains undeniably pertinent and crucial.

This study focuses on researching and comparing bio-inspired swarm techniques in addressing the task of parametric optimization for the Takagi-Sugeno fuzzy ACS, tailored for an inspection mobile robotic platform. This platform exhibits the capability to traverse inclined and vertical surfaces, functioning as a self-sufficient tool for executing intricate

inspection and monitoring operations in challenging and hazardous environments present in various industrial facilities and urban settings inaccessible to humans. However, to fully leverage the potential of this mobile platform, an intelligent control system optimized through an advanced method is imperative. Herewith, choosing the most appropriate method to achieve high efficiency while keeping computational costs relatively low can indeed be a challenging endeavor. Thus, the primary objective of this paper is the implementation of the efficiency research and comparative analysis of several modifications (basic and hybrid) of PSO and GWO swarm techniques, previously adapted for the parametric optimization of fuzzy ACSs.

2. Fuzzy automatic control system for the inspection mobile robotic platform

Mobile robotic platforms designed for traversing both inclined and vertical surfaces are effectively deployed for conducting inspection and monitoring operations in demanding and hazardous environments found in a variety of industrial facilities and urban areas inaccessible to humans [32-36]. Moreover, robotic platforms of this kind can be employed in critical infrastructure facilities, even for executing intricate tasks of utmost importance [37]. Such platforms have magnetic clamping devices for moving along ferromagnetic surfaces and belong to the class of complex technical plants, for which it is beneficial to use fuzzy automatic control systems to automate movement processes [36, 38-40]. This study focuses on researching and comparing bio-inspired swarm optimization methods by examining the application of the Takagi-Sugeno fuzzy ACS for controlling the speed of the MRP movement on an inclined surface. To ensure high-quality control of the speed of spatial motion and, accordingly, the overall efficiency of performing various technological operations by the MRP on inclined ferromagnetic surfaces, it is advisable to use the combined fuzzy ACS, which is based on the model of combined fuzzy control proposed in [41]. In turn, the structure of the combined fuzzy ACS for the MRP developed with the built-in dynamic model of the control plant is presented in Fig. 1, where the following notations are adopted: SD is the setting device; CFC is the combined fuzzy controller; FC is the function converter; FSS1 and FSS2 are first and second fuzzy subsystems that are used in the second and third control channels, respectively; DMRP is the dynamic model of the robotic platform built into the controller; LU is the limiting unit designed to limit the maximum value of the controller's output signal; SS is the speed sensor; v_s and v_R are the set and real values of the movement speed of the mobile platform along an inclined operating surface; u_{SD} , u_{SS} , u_M , u_F , u_1 , u_2 , and u_{FC} are the corresponding output signals of the SD, SS, DMRP, FC, FSS1, FSS2, and CFC; e_v and e_v are the control errors formed in the second and third control channels, respectively; \dot{e}_v and \dot{e}_v are the control errors derivatives, respectively; K_{P1} , K_{D1} , K_{P2} , K_{D2} are the normalizing factors; F_D is the vector of disturbances acting on the robotic platform during movement.

The given combined fuzzy ACS of the mobile robotic platform with the presented structure (Fig. 1) has a combined fuzzy controller that contains three main control channels. The first control channel is a feedforward channel, which is implemented using a function converter FC with an inverse static characteristic of the MRP ($u_F = f(u_{SD})$). In turn, this static characteristic is built using the basic equations of the MRP's mathematical model [34, 38] in a

static mode and without taking into account the disturbances acting on the MRP during its movement and technological operations implementation.

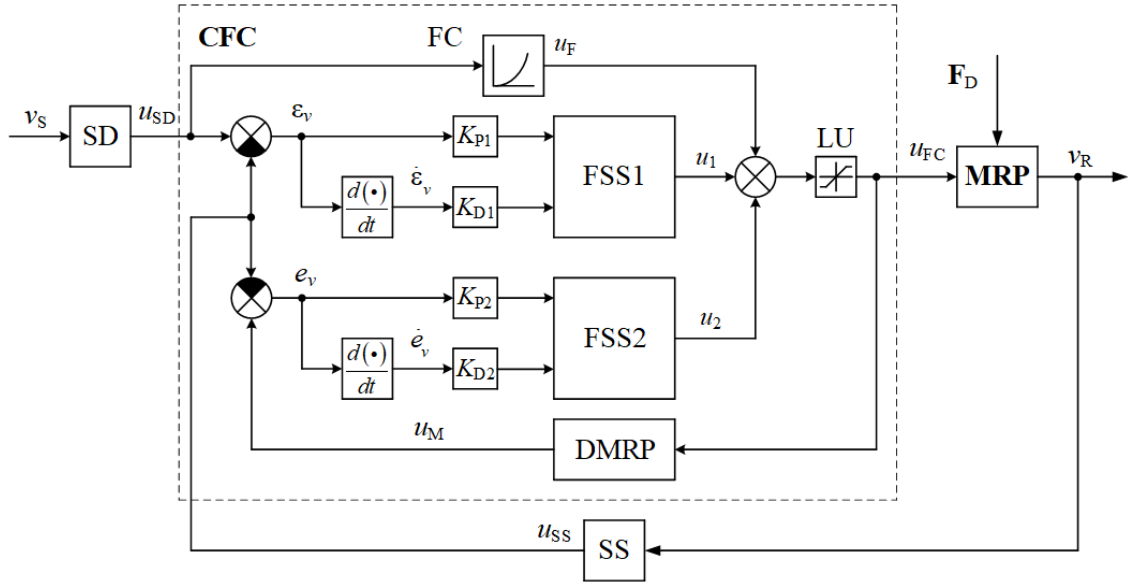

Figure 1: Functional structure of the combined fuzzy ACS for the MRP.

The second channel is the main feedback control channel, implemented on the basis of the speed sensor and the first fuzzy subsystem FSS1. In turn, the main control error ϵ_v and its derivative $\dot{\epsilon}_v$ are the main input variables of the FSS1. The third control channel is an additional feedback channel, implemented on the basis of the built-in dynamic model DMRP of the robotic platform and the fuzzy subsystem FSS2, which are used to indirectly determine and compensate for all existing disturbances F_D . The error e_v , which is caused only by the action of disturbances F_D , is defined in this channel as the deviation of the sensor's output signal u_{SS} from the output signal of the built-in platform's model u_M ($e_v = u_M - u_{SS}$). Since the same control signal u_{FC} is received simultaneously at the inputs of the MRP and its dynamic model, the presence of an error e_v will indicate the presence of the disturbances F_D acting on the MRP. Thus, in this control channel, the current value of the disturbances F_D is determined based on the error value e_v . In order to take into account the change of the disturbances F_D effects over time, it is also advisable to determine the derivative of the error \dot{e}_v and use it as the second input of the FSS2. In turn, the built-in dynamic model of the MRP contains the main equations presented in paper [38] without taking into account disturbances (the load moments of the motors of electric drives are equal to 0). The normalizing factors K_{P1} , K_{D1} , K_{P2} , K_{D2} are used to bring input signals of the FSS1 and FSS2 to relative units from their maximum value. The specified value of the required movement speed v_s of the platform along an inclined working surface can be set from the upper-level control system, which is advisable to be implemented based on the Internet of Things technology [42-44].

The control signal of the developed CFC with a built-in dynamic MRP's model is calculated as follows:

$$u_{FC} = u_F + u_1 + u_2 = f(u_{SD}) + f_{FSS1}(K_{P1}\varepsilon_v, K_{D1}\dot{\varepsilon}_v) + f_{FSS2}(K_{P2}e_v, K_{D2}\dot{e}_v). \quad (1)$$

In this paper, for the comparative analysis of the efficiency of the studied hybrid swarm methods, the parametric optimization of the Takagi-Sugeno FSS1 and FSS2 was carried out for the combined ACS with a built-in model of the MRP's movement speed. In turn, the vector \mathbf{X} of parameters to be optimized, in this case, is given by the expression (2)

$$\mathbf{X} = \{\mathbf{K}_i, \mathbf{P}_{LT1}, \mathbf{P}_{LT2}, \mathbf{P}_{C1}, \mathbf{P}_{C2}\}, \quad (2)$$

where \mathbf{K}_i is the vector of normalizing factors consisting of coefficients K_{P1} , K_{D1} , K_{P2} , K_{D2} ; \mathbf{P}_{LT1} and \mathbf{P}_{LT2} are the vectors of adjustable parameters of the linguistic terms for the FSS1 and FSS2, accordingly; \mathbf{P}_{C1} and \mathbf{P}_{C2} are the vectors of weighting gains for the consequences of the RB rules for the FSS1 and FSS2, accordingly.

For the first input signals of the FSS1 and FSS2 ($K_{P1}\varepsilon_v$, $K_{P2}e_v$), 5 LTs of the triangular type were selected: BN (big negative); SN (small negative); Z (zero); SP (small positive); BP (big positive). In turn, for the second input signals of the FSS1 and FSS2 ($K_{D1}\dot{\varepsilon}_v$, $K_{D2}\dot{e}_v$), 3 terms of the triangular type were selected: N (negative); Z (zero); P (positive). Thus, the \mathbf{P}_{LT1} and \mathbf{P}_{LT2} vectors contain 24 adjustable parameters each, which are subject to optimization.

The FSS1 and FSS2 rule bases consist of 15 rules each. In turn, the r -th RB rules for the FSS1 and FSS2 are given by the expressions (3) and (4), respectively:

$$\text{IF } "K_{P1}\varepsilon_v = LT_1" \text{ AND } "K_{D1}\dot{\varepsilon}_v = LT_2" \text{ THEN } "u_1 = k_{11r}(K_{P1}\varepsilon_v) + k_{12r}(K_{D1}\dot{\varepsilon}_v)"; \quad (3)$$

$$\text{IF } "K_{P2}e_v = LT_1" \text{ AND } "K_{D2}\dot{e}_v = LT_2" \text{ THEN } "u_2 = k_{21r}(K_{P2}e_v) + k_{22r}(K_{D2}\dot{e}_v)", \quad (4)$$

where k_{11r} , k_{12r} are the weighting gains of the r -th rule of the FSS1 rule base; k_{21r} , k_{22r} are the weighting gains of the r -th rule of the FSS2 rule base.

Thus, the vectors of weighting gains for the consequences \mathbf{P}_{C1} and \mathbf{P}_{C2} contain 30 coefficients each, which are subject to optimization.

In total, the vector \mathbf{X} of parameters to be optimized, in this case, consists of 112 parameters.

Following that, we proceed directly to optimizing the parameters of the presented combined fuzzy control system to implement efficiency research and comparative analysis of several modifications (basic and hybrid) of PSO and GWO swarm methods.

3. Bio-inspired parametric optimization of the combined fuzzy control system for the inspection robotic platform

The authors suggest conducting the parametric synthesis and optimization of the given combined fuzzy control system utilizing effective and well-established bio-inspired methods, such as PSO and GWO [14, 15, 18, 45], alongside their several modifications hybridized with local search methods to expedite convergence. Specifically, hybrid modifications of the PSO based on the elite strategy with the gradient descent (GD) algorithm and the extended Kalman filter (EKF) algorithm, as proposed in [38], are to be applied. Additionally, an improved GWO method [45] and its hybridization with GD and EKF techniques, as suggested in the paper [46], are considered. Lastly, for comprehensive comparison, it is recommended to optimize the fuzzy control system's parameters using individual local search GD and EKF techniques.

The main principles of the PSO method, along with its application for synthesizing and parametrically optimizing FSs, are extensively discussed in [14, 18]. Furthermore, the authors proposed hybridizing PSO with GD and EKF based on the elite strategy to enhance FS optimization processes in [38]. The core concept of these modifications involves enabling an independent parallel search by the best swarm particle using GD or EKF, thereby potentially accelerating convergence and reducing computational costs associated with these algorithms. The fundamental principles of both the basic and improved GWO methods are elaborated in [15] and [45]. The improved method integrates an additional dimension learning-based hunting (DLH) strategy to enhance population diversity and mitigate premature convergence to suboptimal solutions [45]. In the study [46], the authors proposed hybridizing the enhanced GWO with local search techniques of GD and EKF. To achieve this, akin to hybrid PSO methods, alpha, beta, and delta wolves of the pack are tasked with conducting local searches in their vicinity using GD or EKF, in addition to employing group hunting and DLH strategies.

In this study, the expression (5) was chosen as the objective function \mathcal{J} for the implementation of the optimization processes, which is the generalized integral deviation of the systems' real transient characteristic $v_R(t, \mathbf{X})$ from the desired characteristic $v_D(t)$ of its reference model (RM) [38].

$$J(t, \mathbf{X}) = \frac{1}{t_{\max}} \int_0^{t_{\max}} [(E_v)^2 + k_{j1}(\dot{E}_v)^2 + k_{j2}(\ddot{E}_v)^2] dt, \quad (5)$$

where t_{\max} is the total transient time of the combined fuzzy control system; k_{j1} , k_{j2} are the weighting factors of the objective function; E_v is the deviation of $v_R(t, \mathbf{X})$ from $v_D(t)$, $E_v = v_D(t) - v_R(t, \mathbf{X})$.

In turn, the reference model of the MRP's control system is presented by the following transfer function:

$$W_{\text{RM}}(s) = \frac{v_D(s)}{v_S(s)} = \frac{1}{(T_{\text{RM}}s + 1)^2}, \quad (6)$$

where T_{RM} is the time constant of the reference model.

The optimal value of the objective function was chosen to be $\mathcal{J}_{\text{opt}} = 0.2$, which had to be achieved during the optimization process. However, in order to carry out full-fledged research, the maximum number of iterations $N_{\max} = 200$ was chosen as the criterion for the end of the optimization. Moreover, when implementing the search procedures, the following adjustable parameters of the PSO algorithms were selected: particles number in the swarm $Z_{\max} = 30$; maximum particles velocity $V_{\max} = 10$; accelerations values $C_1 = C_2 = 0.1$. As for the GWO-methods modifications, the number of wolves in the pack $Z_{\max} = 30$. In addition, in this case, the same restrictions were applied as in [38].

The parametric optimization procedures of the vector \mathbf{X} were carried out in turn using each of the studied swarm methods 5 times with the subsequent selection of the best results. When calculating the values of the objective function (5) at each iteration, the simulation of the transients for the combined fuzzy system of the MRP speed control was carried out in different operating modes, in particular, under the influence of strong step disturbances.

For assessing the efficacy of the swarm optimization methods employed in this study, it is recommended to compare the obtained best values of the objective function \mathcal{J}_{\min} along with

the computational costs incurred. Additionally, the computational expenses needed to attain the specified optimal value of the objective function \mathcal{J}_{opt} are utilized for evaluation. In this context, the computational costs of the analyzed methods primarily hinge on the total number of times v_j of the objective function calculation required to achieve its specific values ($v_{j_{opt}}$ for reaching the optimal value \mathcal{J}_{opt} , and $v_{j_{min}}$ for attaining the best value \mathcal{J}_{min}).

The Fig. 2 shows the curves of changes in the best values of the objective function (5) in the optimization process of the vector \mathbf{X} utilizing the studied methods: 1 – basic PSO *Gbest*; 2 – hybrid PSO with GD; 3 – hybrid PSO with EKF; 4 – basic GWO; 5 – IGWO (improved GWO); 6 – hybrid IGWO with GD; 7 – hybrid IGWO with EKF; 8 – GD; 9 – EKF.

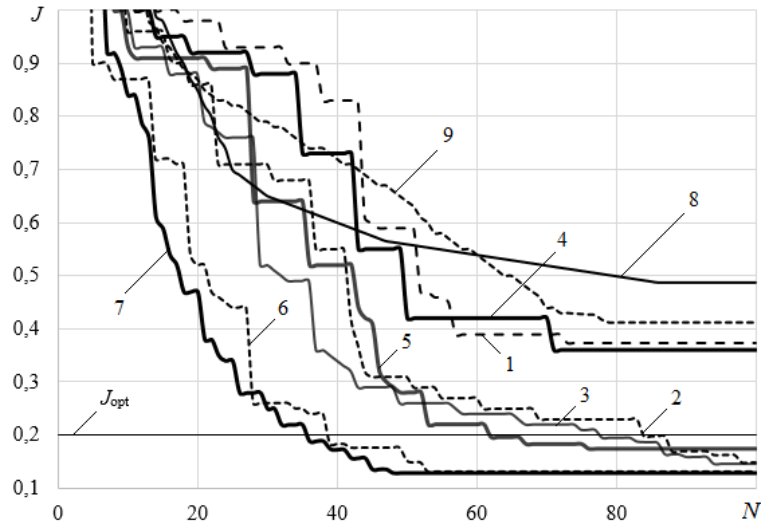

Figure 2: Curves of changes in the best values of the objective function \mathcal{J} during the optimization process of the combined fuzzy ACS for MRP speed (in the range of iterations $N = 0 \dots 100$).

The best results of the computational experiments obtained in the process of optimization of vector \mathbf{X} using each of the studied methods are summarized in Table 1.

Table 1

The best experimental results obtained in the optimization process of the combined fuzzy ACS for MRP

Optimization method	$N_{j_{opt}}$	$v_{j_{opt}}$	\mathcal{J}_{min}	$N_{j_{min}}$	$v_{j_{min}}$
Basic PSO <i>Gbest</i>	144	4206	0.183	167	4873
Hybrid PSO with GD	84	2550	0.149	98	2970
Hybrid PSO with EKF	78	2370	0.146	94	2850
Basic GWO	139	3783	0.178	153	4161
IGWO	62	3378	0.174	76	4134
Hybrid IGWO with GD	39	2253	0.131	53	3051
Hybrid IGWO with EKF	36	2082	0.129	48	2766
GD	-	-	0.479	87	87
EKF	-	-	0.412	79	79

In turn, for swarm methods and their various modifications (hybrid and improved), the parameters $v_{\bar{j}_{opt}}$ and $v_{\bar{j}_{min}}$ are significantly greater than the corresponding number of iterations $N_{\bar{j}_{opt}}$ and $N_{\bar{j}_{min}}$, since the calculation of the objective function at each iteration must be performed for each agent of the flock (swarm). As for the gradient method and the algorithm of the extended Kalman filter taken separately, the number of calculations of the objective function $v_{\bar{j}_{min}}$, which is necessary to achieve its minimum value \bar{j}_{min} , is equal to the number of iterations $N_{\bar{j}_{min}}$.

As can be seen from Fig. 2 and Table 1, the hybrid IGWO methods have a generally higher efficiency compared to the hybrid PSO methods when performing parametric optimization of fuzzy subsystems (FSS1, FSS2) of the combined ACS for the mobile robotic platform. Therefore, employing the hybrid IGWO methods with EKF and GD necessitated, at best, 288 and 297 fewer evaluations of the objective function \bar{j} , respectively, compared to using the hybrid PSO methods based on the elite strategy with EKF and GD. Furthermore, on average, the utilization of the hybrid IGWO methods resulted in attaining a lower minimum value of the objective function \bar{j}_{min} compared to the hybrid PSO methods.

For addressing this particular problem (optimization of the combined fuzzy ACS for MRP), the most efficient approach is the hybrid IGWO method with EKF. Through its implementation, it was feasible to attain the optimal value of the objective function for the combined fuzzy ACS ($\bar{j} \leq 0.2$) with the fewest number of evaluations of the objective function ($v_{\bar{j}_{opt}} = 2082$). Furthermore, employing this method led to the achievement of the lowest value of the target function ($\bar{j}_{min} = 0.129$) on the 48th iteration (Fig. 2, curve 7).

Regarding the gradient method and the extended Kalman filter algorithm used individually, while their implementation entails considerably lower computational and time costs compared to bio-inspired swarm methods, they were unable to attain the optimal value of the objective function ($\bar{j} \leq 0.2$) in addressing this problem.

In turn, the optimized parameters of the obtained vector \mathbf{X}_{best} have the following values. For the vector of normalizing factors \mathbf{K} , the following values of its components were found: $K_{P1} = 6.44$; $K_{D1} = 0.29$; $K_{P2} = 11.27$; $K_{D2} = 0.81$. As for the linguistic terms for the input variables of the FSS1 and FSS2, their appearance with optimized parameters is presented in Fig. 3.

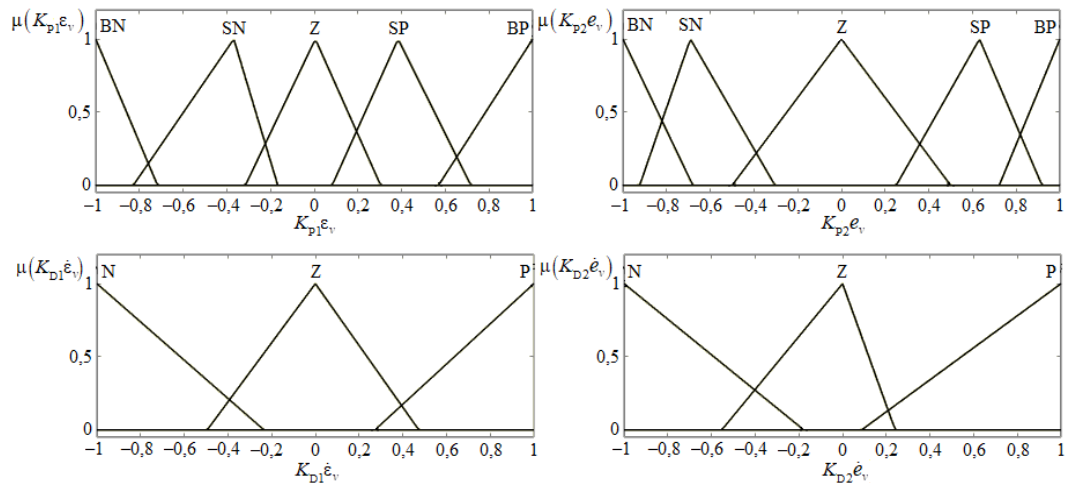

Figure 3: LTs with optimized parameters for the input signals of the FSS1 and FSS2 for the MRP's combined fuzzy ACS.

Parts of the RBs from the fuzzy subsystems, optimized using the hybrid IGWO method with the EKF to achieve the minimum objective function value, are outlined in Table 2.

Table 2

Parts of the rule bases for the FSS1 and FSS2 of the combined fuzzy ACS for MRP

Rule number	Linguistic terms of the input variables		Weighting gains of the rules' consequents	
	Part of the rule base for the FSS1			
	$K_{P1}e_v$	$K_{D1}\dot{e}_v$	k_{11r}	k_{12r}
1	BN	N	79.24	46.21
3	BN	P	34.26	11.32
5	SN	Z	92.11	75.7
10	SP	N	76.82	73.04
15	BP	P	19.01	56.14

Rule number	Part of the rule base for the FSS2			
	$K_{P2}e_v$	$K_{D2}\dot{e}_v$	k_{21r}	k_{22r}
1	BN	N	51.03	20.16
3	BN	P	21.12	8.36
5	SN	Z	82.45	68.2
10	SP	N	59.71	54.94
15	BP	P	11.8	44.71

Additionally, the complete vectors of optimized weighting gains \mathbf{P}_{C1} and \mathbf{P}_{C2} take the following form:

$\mathbf{P}_{C1} = \{79.24; 46.21; 95.37; 81.12; 34.26; 11.32; 68.75; 60.8; 92.11; 75.7; 9.43; 31.08; 47.89; 69.13; 69.38; 54.02; 87.28; 72.36; 76.82; 73.04; 72.87; 52.75; 64.41; 51.12; 43.65; 69.09; 33.54; 21.72; 19.01; 56.14\};$

$\mathbf{P}_{C2} = \{51.03; 20.16; 67.04; 63.87; 21.12; 8.36; 54.63; 47.11; 82.45; 68.2; 5.76; 26.13; 35.71; 54.2; 51.07; 47.13; 69.82; 66.16; 59.71; 54.94; 52.09; 37.4; 50.11; 36.47; 33.18; 57.65; 22.05; 14.39; 11.8; 44.71\}.$

Next, let's proceed to the outcomes of simulation experiments conducted on the developed combined fuzzy control system to validate the efficacy of the swarm optimization methods under study.

4. Simulation experiments of the combined fuzzy control system for the inspection robotic platform

To confirm the effectiveness of the developed combined fuzzy ACS with the optimized parameters of the FSS1 and FSS2 based on the considered hybrid IGWO method with EKF, the Fig. 4 presents the transients of the MRP motion under strong step disturbances. In turn, the curves 1, 2 and 3 are the outputs of the system (the real value of the MRP movement speed v_R) with the combined fuzzy controller (based on the FSS1 and FSS2, optimized using the hybrid IGWO method with EKF), the fuzzy PID controller (developed in [38]) and the optimally tuned traditional PID controller. The line 4 is a stepped disturbance varying in the range from 0 to

600 N. In turn, the parameters of the traditional PID controller are as follows: $k_p = 6.5$; $k_d = 0.23$; $k_i = 422.4$. Moreover, the Fig. 5 illustrates the detailed transient processes of the MRP movement in the presence of step disturbances.

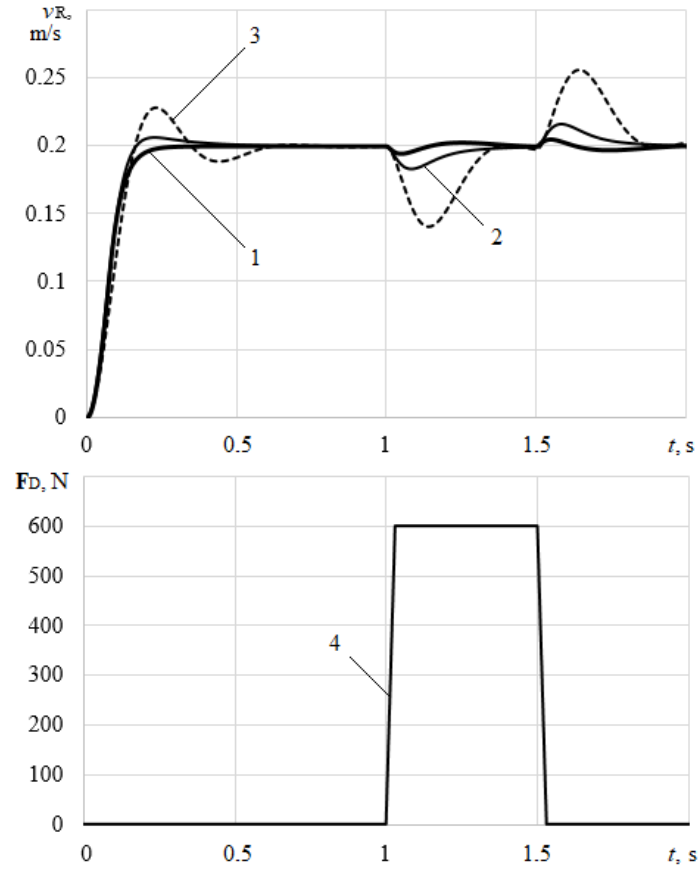

Figure 4: Transients of the MRP movement under conditions of disturbances.

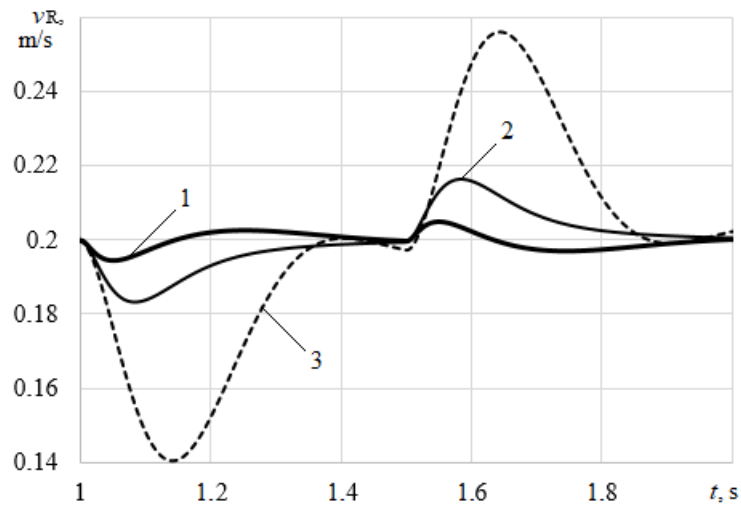

Figure 5: Detailed transients of the MRP movement under conditions of step disturbances.

Additionally, Table 3 offers a comparative analysis of the control system's quality indicators for the MRP's speed during these transients (actual value of the MRP movement speed v_k) under strong step disturbance conditions.

Table 3

Analysis of the quality indicators of ACS for MRP under conditions of disturbances

Quality indicators of the MRP's speed control system	Quality indicators' values		
	Traditional PID controller	Fuzzy PID controller	Combined fuzzy controller
Amplitude of disturbance, N	600	600	600
The duration of the disturbance, s	0.75	0.75	0.75
Regulating time, s	0.34	0.27	0.21
The maximum speed deviation under the influence of disturbance, %	30.05	8.3	2.1

It is evident from Fig. 4, 5, and Table 3 that the combined fuzzy control system for the mobile robotic platform with optimized FSS1 and FSS2 using the hybrid IGWO method with EKF exhibits notably superior control quality indicators compared to systems relying on optimized fuzzy and traditional PID controllers.

5. Conclusions

This study conducts research and comparative analysis on swarm bio-inspired methods for optimizing parameters in fuzzy systems. Specifically, it compares various hybrid modifications of particle swarm optimization and grey wolf optimization swarm techniques, customized for optimizing FS parameters, both amongst themselves and with conventional search methods.

The research and comparative analysis are conducted using a specific case study: the parametric optimization of a Takagi-Sugeno fuzzy control system devised for an inspection mobile robotic platform. The simulation results demonstrate that hybrid IGWO methods generally exhibit higher efficiency compared to hybrid PSO methods when optimizing parameters of fuzzy subsystems (FSS1, FSS2) within the combined ACS for the MRP. Among these methods, the hybrid IGWO method with EKF emerges as the most efficient approach for this particular problem. Its implementation enables the attainment of the optimal objective function value for the combined fuzzy ACS ($J \leq 0.2$) with the least number of objective function evaluations ($v_{jopt} = 2082$).

Furthermore, the combined fuzzy ACS utilizing FSS1 and FSS2, due to the use of three control channels and a built-in MRP's model, coupled with a highly efficient parameter optimization method, demonstrates superior speed when accelerating the MRP to the specified velocity. It also exhibits smaller deviations (no more than 2.1%) during strong step disturbance operations compared to the ACS employing a fuzzy PID controller. Moreover, identifying the optimal variant of the vector \mathbf{X}_{best} for FSS1 and FSS2 of the combined ACS using the hybrid IGWO method with EKF incurred minimal computational and time expenses

($v_{j\min} = 2766$), thereby corroborating the overall effectiveness of this hybrid swarm optimization method for parameter optimization, as well as the proposed fuzzy combined ACS model.

Acknowledgements

This study is financially supported by the National High Level Foreign Experts Introduction Project, China (G2022014116L).

References

- [1] A. Gogna, A. Tayal, Metaheuristics: review and application. *Journal of Experimental & Theoretical Artificial Intelligence* 25 (2013) 503-526.
- [2] M.V. Maksimov, S.N. Pelykh, R.L. Gontar, Principles of controlling fuel-element cladding lifetime in variable VVER-1000 loading regimes, *Atomic Energy* 112(4) (2012) 241-249. <https://doi.org/10.1007/s10512-012-9552-3>.
- [3] Y.P. Kondratenko, O.V. Korobko, O.V. Kozlov, Frequency Tuning Algorithm for Loudspeaker Driven Thermoacoustic Refrigerator Optimization, in: K. J. Engemann, A. M. Gil-Lafuente, J. M. Merigo (Eds.), *Lecture Notes in Business Information Processing*, volume 115 of *Modeling and Simulation in Engineering, Economics and Management*, Springer-Verlag, Berlin, Heidelberg: 2012, pp. 270-279. https://doi.org/10.1007/978-3-642-30433-0_27.
- [4] A.I. Brunetkin, M.V. Maksimov, The method for determination of a combustible gas composition during its combustion, *Naukovyi Visnyk Natsionalnoho Hirnychoho Universytetu* 5 (2015) 83-90. <http://nvngu.in.ua/index.php/uk/arkhiv-zhurnalu/za-vipuskami/1132-2015/zmist-5-2015/tekhnologiji-energozabezpechennya/3162-metod-viznachennya-skladu-goryuchikh-gaziv-pri-jikh-spalyuvanni>.
- [5] T. Mai, D. Mortari, Theory of functional connections applied to quadratic and nonlinear programming under equality constraints, *Journal of Computational and Applied Mathematics* 406 (2022) 113912.
- [6] O. Kozlov, et al., Synthesis and Optimization of Green Fuzzy Controllers for the Reactors of the Specialized Pyrolysis Plants, in: Kharchenko V., Kondratenko Y., Kacprzyk J. (Eds.), *Green IT Engineering: Social, Business and Industrial Applications*, volume 171 of *Studies in Systems, Decision and Control*, Springer, Cham, 2019, pp. 373-396. doi: 10.1007/978-3-030-00253-4_16.
- [7] M.A. Elsisy, M.A. El Sayed, Y. Abo-Elnaga, A novel algorithm for generating Pareto frontier of bi-level multi-objective rough nonlinear programming problem, *Ain Shams Engineering Journal* 12(2) (2021) 2125-2133.
- [8] D. Simon, *Evolutionary Optimization Algorithms: Biologically Inspired and Population-Based Approaches to Computer Intelligence*, John Wiley & Sons, 2013.
- [9] I. Boussaïd, J. Lepagnot, P. Siarry, A survey on optimization metaheuristics, *Information Sciences* 237 (2013) 82-117.
- [10] C. Blum, et al., Hybrid metaheuristics in combinatorial optimization: a survey, *Applied Soft Computing* 11(6) (2011) 4135-4151.
- [11] O.V. Kozlov, Optimal Selection of Membership Functions Types for Fuzzy Control and Decision Making Systems, in: *Proceedings of the 2nd International Workshop on*

- Intelligent Information Technologies & Systems of Information Security with CEUR-WS, Khmelnytskyi, Ukraine, IntelITSIS 2021, CEUR-WS, Vol-2853, 2021, pp. 238-247.
- [12] X. Wang, G. Wang, S. Li, A distributed fixed-time optimization algorithm for multi-agent systems, *Automatica* 122 (2020) 109289.
- [13] W. Pedrycz, K. Li, M. Reformat, Evolutionary reduction of fuzzy rule-based models, in: *Fifty Years of Fuzzy Logic and its Applications*, volume 326 of STUDEFUZ, Cham, Springer, 2015, pp. 459-481.
- [14] S. Muthukaruppan, M. J. Er, A hybrid particle swarm optimization based fuzzy expert system for the diagnosis of coronary artery disease, *Expert Systems with Applications* 39(14) (2012) 11657-11665.
- [15] S. Mirjalili, S. M. Mirjalili, A. Lewis, Grey wolf optimizer, *Adv. Eng. Software* 69 (2014) 46-61.
- [16] S. Chakraborty, K. Mali, Biomedical image segmentation using fuzzy multilevel soft thresholding system coupled modified cuckoo search, *Biomedical Signal Processing and Control* 72(B) (2022) 103324.
- [17] S. Mirjalili, The Ant Lion Optimizer, *Advances in Engineering Software* 83 (2015) 80-98.
- [18] S. Vaneshani, H. Jazayeri-Rad, Optimized Fuzzy Control by Particle Swarm Optimization Technique for Control of CSTR, *International Journal of Electrical and Computer Engineering* 5(11) (2011) 1243-1248.
- [19] A. M. Altabeeb, et al., Solving capacitated vehicle routing problem using cooperative firefly algorithm, *Applied Soft Computing* 108 (2021) 107403.
- [20] A. Kaveh, et al., Chaotic swarming of particles: a new method for size optimization of truss structures, *Adv. Eng. Softw.* 67 (2014) 136-147.
- [21] S. Mirjalili, The Whale Optimization Algorithm, *Advances in Engineering Software* 95 (2016) 51-67.
- [22] T. B., Thang, H. T. T. Binh, A hybrid multifactorial evolutionary algorithm and firefly algorithm for the clustered minimum routing cost tree problem, *Knowledge-Based Systems*, 241 (2022) 108225.
- [23] L. D. Seixas, H. G. Tosso, F. C. Corrêa, J. J. Eckert, Particle Swarm Optimization of a Fuzzy Controlled Hybrid Energy Storage System - HESS, in: *2020 IEEE Vehicle Power and Propulsion Conference (VPPC)*, Gijon, Spain, 2020, pp. 1-6. doi: 10.1109/VPPC49601.2020.9330939.
- [24] O. Castillo, P. Melin, An Approach for Optimization of Intuitionistic and Type-2 Fuzzy Systems in Pattern Recognition Applications, in: *2019 IEEE International Conference on Fuzzy Systems (FUZZ-IEEE)*, New Orleans, LA, USA, 2019, pp. 1-5, doi: 10.1109/FUZZ IEEE.2019.8858951.
- [25] O.V. Kozlov, Information Technology for Designing Rule Bases of Fuzzy Systems using Ant Colony Optimization, *International Journal of Computing* 20(4) (2021) 471-486. <https://www.computingonline.net/computing/article/view/2434>.
- [26] P. Ponce, et al., Optimization of Fuzzy Logic Controllers by Particle Swarm Optimization to Increase the Lifetime in Power Electronic Stages, in: Adel El-Shahat (Ed.), *Electric Machines for Smart Grids Applications – Design, Simulation and Control*, IntechOpen, 2018, pp. 213-233.

- [27] M. Algabri, et al., Optimization of Fuzzy Logic Controller using PSO for Mobile Robot Navigation in an Unknown Environment, *Applied Mechanics and Materials* 541-542 (2014) 1053-1061.
- [28] M. Collotta, G. Pau, V. Maniscalco, A Fuzzy Logic Approach by Using Particle Swarm Optimization for Effective Energy Management in IWSNs, *IEEE Transactions on Industrial Electronics* 64(12) (2017) 9496-9506. doi: 10.1109/TIE.2017.2711548.
- [29] V. Maniscalco, F. Lombardo, A PSO-based approach to optimize the triangular membership functions in a fuzzy logic controller, in: *AIP Conference Proceedings* 1906, 2017, 1900111. <https://doi.org/10.1063/1.5012474>.
- [30] B.P. Sahoo, S. Panda, Improved grey wolf optimization technique for fuzzy aided PID controller design for power system frequency control, *J. Sustainable Energy, Grids and Networks* 16 (2018) 278-299.
- [31] E. Hernandez, O. Castillo, J. Soria, Optimization of fuzzy controllers for autonomous mobile robots using the grey wolf optimizer, in: *2019 IEEE International Conference on Fuzzy Systems (FUZZ-IEEE)*, New Orleans, LA, USA, 2019, pp. 1-6.
- [32] M. Karimi, et al. ReMoRo; A mobile robot platform based on distributed I/O modules for research and education, in: *2015 3rd RSI International Conference on Robotics and Mechatronics (ICROM)*, Tehran, Iran, 2015, pp. 657-662, DOI: 10.1109/ICRoM.2015.7367861.
- [33] D. Maia, A. Coelho, M. Ricardo, Obstacle-aware On-demand 5G Network using a Mobile Robotic Platform, in: *2022 18th International Conference on Wireless and Mobile Computing, Networking and Communications (WiMob)*, Thessaloniki, Greece, 2022, pp. 470-473, doi: 10.1109/WiMob55322.2022.9941633.
- [34] Y.P. Kondratenko, et al., Features of clamping electromagnets using in wheel mobile robots and modeling of their interaction with ferromagnetic plate, in: *Proc. of the 9th IEEE International Conference on Intelligent Data Acquisition and Advanced Computing Systems: Technology and Applications (IDAACS)*, Vol. 1, Bucharest, Romania, 2017, pp. 453-458. doi: 10.1109/IDAACS.2017.8095122.
- [35] V. Mazur, Robotic Mobile Platform for Container Transportation, in: *2021 IEEE 16th International Conference on the Experience of Designing and Application of CAD Systems (CADSM)*, Lviv, Ukraine, 2021, pp. 10-13. doi: 10.1109/CADSM52681.2021.9385212.
- [36] O. Kozlov, et al., Swarm Optimization of Fuzzy Systems for Mobile Robots with Remote Control, *Journal of Mobile Multimedia* 19(3) (2023) 839-876. <https://doi.org/10.13052/jmm1550-4646.1939>.
- [37] S. Alyokhina, I. Nevludov, Y. Romashov, Safe Transportation of Nuclear Fuel Assemblies by Means of Wheeled Robotic Platforms, *Nuclear and Radiation Safety* 3(91) (2021) 43-50. [https://doi.org/10.32918/nrs.2021.3\(92\).05](https://doi.org/10.32918/nrs.2021.3(92).05).
- [38] Y.P. Kondratenko, A.V. Kozlov, Parametric optimization of fuzzy control systems based on hybrid particle swarm algorithms with elite strategy, *Journal of Automation and Information Sciences* 51(12) (2019), 25-45. doi: 10.1615/JAutomatInfScien.v51.i12.40
- [39] R. Duro, et al. (Eds.), *Advances in intelligent robotics and collaborative automation*, River Publishers, Aalborg, 2015. doi: 10.13052/rp-9788793237049.
- [40] Y.P. Kondratenko, et al., Slip displacement sensors for intelligent robots: Solutions and models, in: *Proceedings of the 2013 IEEE 7th International Conference on Intelligent Data*

Acquisition and Advanced Computing Systems, IDAACS 2013, 2, art. no. 6663050, pp. 861-866. doi: 10.1109/IDAACS.2013.6663050.

- [41] Y.P. Kondratenko, O.V. Kozlov, Combined Fuzzy Controllers with Embedded Model for Automation of Complex Industrial Plants, in: Shahnaz N. Shahbazova, Janusz Kacprzyk, Valentina Emilia Balas, Vladik Kreinovich (Eds.), Recent Developments and the New Direction in Soft-Computing Foundations and Applications, volule 393 of Studies in Fuzziness and Soft Computing, Springer, Cham, 2020, pp. 215-228. https://doi.org/10.1007/978-3-030-47124-8_18.
- [42] Y.P. Kondratenko, et al., Internet of Things Approach for Automation of the Complex Industrial Systems, in: Proceedings of the 13th International Conference on Information and Communication Technologies in Education, Research, and Industrial Applications. Integration, Harmonization and Knowledge Transfer, Kyiv, Ukraine, Ermolayev, V. et al. (Eds.), ICTERI'2017, CEUR-WS, Vol-1844, 2017, pp. 3-18.
- [43] R. S. Batth, A. Nayyar, A. Nagpal, Internet of Robotic Things: Driving Intelligent Robotics of Future - Concept, Architecture, Applications and Technologies, in: 2018 4th International Conference on Computing Sciences (ICCS), Jalandhar, India, 2018, pp. 151-160. doi: 10.1109/ICCS.2018.00033.
- [44] M. Basha, et al., Command Control Robot using Internet of Things on Field Programmable Gate Array, in: 2020 International Conference on Electronics and Sustainable Communication Systems (ICESC), Coimbatore, India, 2020, pp. 1068-1073. doi: 10.1109/ICESC48915.2020.9155989.
- [45] M.H. Nadimi-Shahraki, S. Taghian, S. Mirjalili, An improved grey wolf optimizer for solving engineering problems, J. Expert Systems with Applications 166 (2021) 113917.
- [46] O.V. Kozlov, Y.P. Kondratenko, O.S. Skakodub, Information Technology for Parametric Optimization of Fuzzy Systems Based on Hybrid Grey Wolf Algorithms, SN Computer Science 3(6) (2022) 463. <https://doi.org/10.1007/s42979-022-01333-4>.