

# On the Temporal Relation of Top–Down and Bottom–Up Mechanisms during Guidance of Attention

Agnieszka Wykowska and Anna Schubö

## Abstract

■ Two mechanisms are said to be responsible for guiding focal attention in visual selection: bottom–up, saliency-driven capture and top–down control. These mechanisms were examined with a paradigm that combined a visual search task with postdisplay probe detection. Two SOAs between the search display and probe onsets were introduced to investigate how attention was allocated to particular items at different points in time. The dynamic interplay between bottom–up and top–down mechanisms was investigated with ERP methodology. ERPs locked to

the search displays showed that top–down control needed time to develop. N2pc indicated allocation of attention to the target item and not to the irrelevant singleton. ERPs locked to probes revealed modulations in the P1 component reflecting top–down control of focal attention at the long SOA. Early bottom–up effects were observed in the error rates at the short SOA. Taken together, the present results show that the top–down mechanism takes time to guide focal attention to the relevant target item and that it is potent enough to limit bottom–up attentional capture. ■

## INTRODUCTION

### Mechanisms of Selection

When we receive input from the environment through our perceptual apparatus, we obtain an abundance of diverse visual information. Our visual system must have developed mechanisms for selection of important and relevant information in order to function effectively in our world. Two main mechanisms are said to be relevant during the course of selection processes: a so-called bottom–up mechanism (Theeuwes, 1992; Posner, 1980) and a top–down control mechanism (Folk & Remington, 1998, 2006; Müller, Reimann, & Krummenacher, 2003; Wolfe, Butcher, Lee, & Hyle, 2003; Kim & Cave, 1999; Bacon & Egeth, 1994; Wolfe, 1994; Posner, 1980). Bottom–up selection is mainly driven by the properties of the stimulus: When a stimulus is salient, that is, contrasts with the surrounding background, it evokes strong saliency signals that are transmitted in the human perceptual system. On the other hand, when the system “knows” in advance what type of object to look for, it might set weights to those prespecified object properties in a top–down manner. Such a top–down mechanism allows for selection not only on the basis of saliency signals but also with respect to task relevance (Folk & Remington, 1998, 2006; Wolfe, 1994). An open question is to what extent search for a target that differs from the distracters with respect to only one dimension (the so-called search for a popout item) is based on bottom–up processes (Theeuwes, Reimann, & Mortier, 2006; Theeuwes, Atchley, & Kramer, 2000; Theeuwes, 1992) and how it can be modulated by top–

down mechanisms (Geyer, Müller, & Krummenacher, 2008; Folk & Remington, 1998, 2006; Lamy, Tsal, & Egeth, 2003; Müller et al., 2003; Wolfe et al., 2003; Müller, Heller, & Ziegler, 1995; Folk, Remington, & Johnston, 1992).

Authors supporting the “pure” bottom–up perspective claim that search processes involved in target detection in a popout search are impenetrable to top–down mechanisms: Attention is captured to the items in the visual field in the order of decreasing level of salience, regardless of their irrelevance to the task at hand. Goal-driven control comes into play only subsequent to mandatory bottom–up capture (Theeuwes et al., 2000).

Authors postulating that saliency-based processing is penetrable to top–down mechanisms claim that when the target characteristics are known in advance, they will be processed with priority (see the “attentional set” perspective in Folk & Remington, 1998; Folk et al., 1992). Therefore, an irrelevant item might capture attention but only if it shares properties of a predefined target (see also Lien, Ruthruff, Goodin, & Remington, 2008).

### The Temporal Interplay between Top–Down and Bottom–Up Mechanisms

Some researchers focus on the temporal aspect of the interplay between bottom–up and top–down mechanisms of selection (e.g., Kim & Cave, 1999). Kim and Cave (1999) introduced a paradigm in which they combined a visual search task with a postdisplay probe detection task. The visual search task consisted in searching for a shape target among three distracter items. The search displays could contain either the target accompanied by an irrelevant

color singleton or only the irrelevant color singleton (the target-absent displays). After either a short (60 msec) or a long (150 msec) SOA, the search display was followed by a probe item (small filled square) at the former location of either the target or the irrelevant singleton or at a location previously taken by one of the neutral distracters. Probe RTs were analyzed with respect to whether the probe was presented at the former target location, the irrelevant singleton location, or at a neutral distracter location. The authors assumed that the way spatial attention was allocated to particular items of the search display should affect processing of subsequently presented probes and that this should be mirrored in the probe RTs. Varying the SOA between search display and probe onset allowed for investigating the temporal dynamics between bottom-up attentional capture to the salient (but irrelevant) singleton and top-down control of spatial attention toward the less salient (but task-relevant) target. Kim and Cave found that at the long SOA, RTs to probes presented at target locations were faster compared to RTs to probes at distracter locations, which suggested that attention was allocated to the task-relevant item. At the short SOAs (60 msec), RTs to probes presented at irrelevant singleton locations were significantly faster compared to neutral distracter positions. This was interpreted as an effect of bottom-up attention capture to a task-irrelevant salient item at early stages of processing. According to the authors, the two control mechanisms of spatial attention revealed a dynamical interplay: First, the bottom-up mechanism captured attention and only, subsequently, could top-down control take over. However, the bottom-up capture effects were diminished with extensive practice of the observers. Furthermore, the authors did not find capture effects when the irrelevant singleton was located near to the target item or when the display contained only the irrelevant singleton. This suggests that the bottom-up mechanism is penetrable to top-down modulation to some extent. Kim and Cave therefore argued against the “pure capture account” (e.g., Theeuwes et al., 2000; Theeuwes, 1992) by claiming that even at the early stages, when processing is based mainly on bottom-up mechanisms, top-down modulation takes place to some extent.

Yet one may doubt that the behavioral results Kim and Cave (1999) observed in the long SOA condition may indeed be attributed to top-down control of focal attention. For example, Lamy et al. (2003) argue that in a task introduced by Kim and Cave, participants might have detected the target based on a bottom-up singleton-detection mode instead of a top-down strategy based on a set for a particular feature/dimension. Similarly, one may argue that because an irrelevant singleton was always present in a search display (i.e., also in target-absent trials) in the paradigm of Kim and Cave, participants might have developed a strategy of “singleton counting,” that is, they might have performed the task without a proper search. Hence, instead of selecting the target based on top-down mechanisms, participants might have selected the target simply based

on the additional saliency signal induced by its presence. The present experimental design aimed at limiting possible bottom-up strategies in target detection.

Furthermore, behavioral results may not provide a detailed answer to the temporal dynamics of particular processes in the brain. On the contrary, analyzing event-related brain potentials (ERPs) as neurophysiological correlates of stimulus processing may allow for a more detailed and precise examination of the temporal dynamics of the processes of interest (i.e., in this case, bottom-up and top-down control of attention allocation). Because we aimed at investigating how top-down control of visual focal attention develops over time and whether it is present also at early stages of processing, we decided to apply the ERP methodology that allows for investigating attention effects with high temporal resolution. Importantly, the ERP methodology allows for examining particular temporal windows of the processing stream additionally to its end effects, that is, to response execution.

### **Rationale of the Experiment**

We designed a paradigm that combined a visual search task with a probe detection task. Displays contained 19 elements as we were interested in how top-down control is executed in a “real” visual search task with many elements in the visual field. Four types of trials were used, namely, blank trials proper (neutral distracters only), trials with an irrelevant singleton, target trials, and trials in which the search display contained both the target and the irrelevant singleton. Including target-only trials aimed at encouraging a more top-down strategy in target selection than in the case of Kim and Cave (1999). Kim and Cave used only two display types (target and irrelevant singletons as well as irrelevant singletons only). As noted above, in such a paradigm, participants might have applied a bottom-up strategy of singleton counting. In our design, as either of the singletons could have been presented alone, participants should have looked for the shape dimension in order to distinguish it from the color dimension of the irrelevant singleton. Although one cannot completely rule out the possibility of applying the bottom-up singleton detection strategy also in our paradigm as both the target and the irrelevant singleton were still salient items, our design should have limited the bottom-up strategy based solely on the detection of any salience. Furthermore, as the less salient (shape) target singleton had to be detected, whereas the more salient (color) singleton had to be rejected, any target-related attention effects in the probe task were more likely to reflect top-down guidance of attention and not bottom-up based salience detection.

### **Attention Allocation in the Search Display**

Time-locking ERPs to search display onset allows for gaining information about target detection and irrelevant singleton rejection and how they develop over time. If, at early stages

of processing, selection is driven by the saliency of the stimuli and if bottom-up driven attention capture is impenetrable to top-down modulation at this stage of processing, as Theeuwes et al. (2000, 2006) and Theeuwes (1992) postulate, ERPs elicited by the irrelevant but more salient singleton should show effects of attentional capture to the irrelevant singleton, although it is not relevant to the task. Top-down modulation effects on the ERPs related to the target might then occur only later in time. Attention may then be disengaged from the more salient item and shifted to the relevant target location. On the contrary, if bottom-up saliency-based processing is penetrable to top-down mechanisms (as, e.g., Müller et al., 2003; Kim & Cave, 1999; Folk & Remington, 1998 argue), ERPs elicited by the more salient (but irrelevant) singleton should show no effects that would suggest attention allocation to the irrelevant item.

Analyses of the N2pc component, which is an indicator of attention allocation (see, e.g., Jolicoeur, Sessa, Dell'Acqua, & Robitaille, 2006; Woodman & Luck, 2003; Eimer, 1996; Luck & Hillyard, 1994), should provide detailed information concerning the interplay between bottom-up driven and top-down controlled mechanisms. The N2pc is an ERP component that is measured at posterior sites within the time window of ca. 180–300 msec and is more negative on contralateral electrode sites compared to ipsilateral electrode sites relative to an attended object presented in the left or right visual hemifield (Eimer, 1996; Luck & Hillyard, 1994). Although it is not entirely clear whether N2pc reflects a filtering process in the presence of distractors (Luck & Hillyard, 1994) or attentional selection process per se, namely, enhanced processing even in the absence of distractors (Eimer, 1996), N2pc is generally assumed to reflect deployment of attention to objects in the visual field (Jolicoeur et al., 2006; Luck, 2005; Woodman & Luck, 2003; Eimer, 1996). Therefore, by measuring N2pc for targets and irrelevant singletons, one can draw conclusions with respect to whether attention is guided to the target item and/or driven to the irrelevant singleton. If top-down control guides attention to the target, N2pc should be observed in target trials but not in irrelevant singleton trials. If, on the contrary, a bottom-up mechanism drives attention to the irrelevant singleton, N2pc should also be observed for the irrelevant singletons. Displays that contain both a target and an irrelevant singleton in two opposite hemifields allow for a more detailed investigation of the interplay between top-down and bottom-up mechanisms. If the top-down mechanism controls attention in an efficient way, an N2pc relative to the target but not to the irrelevant singleton should be observed. However, if attention is first captured by the irrelevant singleton, the N2pc relative to the target should then exhibit a reduction or even an “inversed polarity,” that is, the ERP waveform should be more negative at electrode sites ipsilateral to the target (as these sites are contralateral to the irrelevant singleton; see Hickey, McDonald, & Theeuwes, 2006 for a similar argumentation).

## Focal Attention at the Probe Location

Assuming that the various search display types lead to differences in attention allocation, *probe-related* ERP components that are sensitive to visual spatial attention (P1 and N1) could also be affected (Hillyard, Vogel, & Luck, 1998; Hopfinger & Mangun, 1998; Luck, Fan, & Hillyard, 1993). Attention effects on the P1–N1 complex have been observed in paradigms where spatial attention has been manipulated. For example, in a paradigm that Mangun, Hillyard, and Luck (1993) applied, observers were fixating in the middle of the screen while a rectangle flashed in one of the quadrants surrounding the fixation cross. Observers were asked to focus their attention on only one of the quadrants. The authors found enhanced P1 and N1 components for attended versus unattended stimuli. Also in standard cueing paradigms (see Posner, 1980), where spatial attention was directed on a trial-by-trial basis, P1 and/or N1 were found to be larger in cued locations relative to noncued locations (Mangun et al., 1993; for reviews, see also Luck, Woodman, & Vogel, 2000; Hillyard et al., 1998).

If target selection is performed by a top-down mechanism that needs time to develop, then P1 and/or N1 should be more enhanced for probes presented at previous target locations relative to probes presented at neutral distracter locations at the long SOA, but not necessarily at the short SOA. Penetrability of bottom-up processing to top-down control should entail no difference in processing of probes presented at the irrelevant singleton compared to a neutral distracter location in either of the SOA conditions. On the contrary, if attention allocation is first driven by the bottom-up saliency signals, P1 and/or N1 might be enhanced for probes presented at the positions previously taken by the irrelevant singletons. Provided that bottom-up driven attention capture to salient singletons is short lived and transient, as, for instance, Van Zoest, Donk, and Theeuwes (2004) claimed, an enhancement of P1 and/or N1 components to probes located at the position of irrelevant singletons should be observed at the short SOA but not necessarily at the long SOA.

## METHODS

### Stimuli and Apparatus

Stimuli were presented on a 17-inch computer screen with a 60-Hz refresh rate placed at a distance of 100 cm from an observer. The items of the search display were positioned on three imaginary circular arrays with diameters of 4.6°, 6.3°, 8° of visual angle on a light-gray background. The outer and middle circles contained eight elements each and the inner circle contained three elements. There were four possible display types: (1) a target-present display (see Figure 1A); (2) a display containing an irrelevant color singleton (see Figure 1C); (3) a display with the target and the irrelevant singleton, (see Figure 1B); and (4) a blank

**Figure 1.** Examples of display types. The upper panels (A) and (B) show displays containing a predefined target (circle among rectangles): (A) is an example of a target-only display, whereas (B) is an example of a display containing both singletons (the target and the irrelevant color singleton). The lower panels (C) and (D) show target-absent displays: (C) is an example of a target-absent display that contains an irrelevant singleton, whereas (D) is an example of a blank display. The solid line represents the blue color of the target and the neutral distracters, whereas the dashed line depicts the red color of the irrelevant singleton.

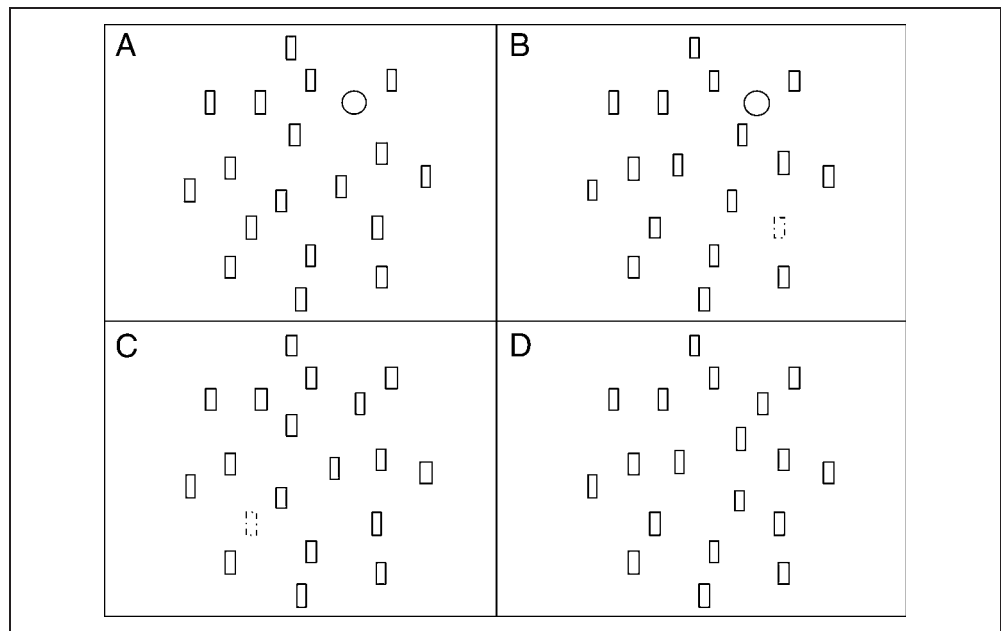

display (see Figure 1D). The target (blue outline circle,  $0.57^\circ$  diameter) could appear at one of four positions (upper left/right or lower left/right from the middle point) of the middle circle of  $4.57^\circ$  of visual angle in diameter. The target was embedded in a set of 18 blue outlines of vertical rectangles ( $0.28^\circ \times 0.74^\circ$  of visual angle)—target-only displays, or in a set of 17 blue rectangular outlines and one red outline—displays containing both the target and the irrelevant singleton. Blank trials consisted of a set of 19 blue rectangular outlines, and displays with only the irrelevant singleton consisted of 18 blue and 1 red rectangular outline. The irrelevant singleton could also appear only at one of the four possible target positions. There was an equal amount of trials (25%) for each search display type. The probe consisted in a filled blue square ( $0.28^\circ \times 0.28^\circ$  of visual angle) and could appear in one of the four possible target positions either in the location previously occupied by the target, by the color-irrelevant singleton, or by one of the other neutral distracters. Participants were seated at 1 m distance from the screen in a dimly lit, electrically shielded, and sound-attenuated chamber with response keys embedded in a response pad (ERTS ExKey) positioned under their hands. Response to the probe detection was to be executed with their dominant hand (left/right button press) and response to the search task was to be executed with the other hand (upper/lower button press).

### Participants

Twenty paid volunteers (13 women) aged from 20 to 31 years (mean age = 24.3 years) took part. Three participants were left-handed and all had normal or corrected-to-normal vision. Visual acuity was tested with a Rodenstock R12 vision tester (stimuli 112). The experiment was con-

ducted with the understanding and consent of each participant. None of the observers had taken part in an experiment with such a paradigm before.

### Procedure

A trial started with a 500-msec fixation display (one-pixel dot in the center of the screen). Subsequently, the search display was presented for 100 msec followed by a probe (in 60% of trials) with either a short (134 msec) or a long (234 msec) SOA.<sup>1</sup> A blank screen was presented during the time interval between search display offset and probe onset. In probe-present trials, the probe appeared subsequently for 67 msec. In probe-absent trials, a blank screen was presented for an additional 67 msec. Participants were asked to press one of the response keys positioned under their dominant hand when they detected the probe and the other key in case there was no probe; the response assignment (index vs. ring finger) was balanced across participants. Participants were asked to respond as fast and as accurately as possible in the probe detection task and as accurately as possible in the search task. Only after participants responded to the probe detection task did a question concerning the target in the search display appear on the screen (see Figure 2). Observers were to respond to this question with a yes/no response with their other hand by pressing the upper or lower response key. Also in this case, the upper/lower assignment was balanced across participants (for visualization of the trial sequence, see Figure 2). All conditions were randomly mixed within blocks of 48 trials. The experiment consisted of 1920 experimental trials divided into two parts (20 blocks per part) preceded by 3 blocks of practice trials. There were 480 trials for each display type, out of which 192 were probe-absent

trials. Probe-present trials were split into the four display types categories and two SOA conditions (144 trials per each display type and each SOA condition) and, for singleton-present trials, two probe positions: “On” one of the singletons (72 trials in one-singleton displays) or “Off”, that is, at the place of one of the neutral distracters (also 72 trials in one-singleton displays). In the displays with both singletons, the number of trials for the “On”-target condition, “On”-irrelevant singleton condition, and “Off” condition was 48 each.

## ERP Recording

EEG was recorded with Ag–AgCl electrodes from 64 electrodes (according to the International 10–10 System). Horizontal and vertical EOGs were recorded bipolarly from the outer canthi of the eyes and from above and below the observer’s left eye, respectively. All electrodes were referenced to Cz and re-referenced off-line to the average of all electrodes. Electrode impedances were kept below 5 k $\Omega$ . Sampling rate was 500 Hz with a high cutoff filter of 125 Hz.

## Data Analysis

### ERP Data

*ERPs locked to search display onset.* This analysis was conducted on probe-absent trials. EEG was averaged off-line over a 700-msec epoch including a 200-msec prestimulus baseline with epochs time-locked to the search display onset. Trials with eye movements and blinks on any recording channel (indicated by any absolute voltage difference in a segment exceeding 80  $\mu$ V or voltage steps between two sampling points exceeding 50  $\mu$ V) were excluded from analysis. Additionally, channels with other artifacts were separately excluded if amplitude exceeded

$\pm 80$   $\mu$ V or any voltage was lower than 0.10  $\mu$ V for a 100-msec interval. Only trials with correct probe and correct search responses were analyzed. Response outliers were also excluded based on the mean RT  $\pm 2$  SD for each participant separately. EEG was averaged for the four search display types, resulting in four ERP waveforms for each participant and each electrode.

In order to investigate the effects on the lateralized N2pc component, the EEG signal was epoched separately for left and right targets/irrelevant singletons. For each singleton, the N2pc waveform was obtained by subtracting activity on the ipsilateral sites from activity on the contralateral sites for the electrode pairs O1/O2, PO3/PO4, and PO7/PO8. A repeated measures analysis of variance (ANOVA) was performed for probe-absent trials on the N2pc mean amplitudes obtained in the 180–300 msec time window with the factors task relevance (target vs. irrelevant), display type (one singleton only vs. both singletons), and electrode pair (O1/O2, PO3/PO4, and PO7/PO8). Statistics were corrected according to Greenhouse–Geisser when appropriate.

*Probe-locked ERPs.* This analysis was conducted on probe-present trials. EEG was averaged off-line over 600-msec epochs including a 200-msec prestimulus baseline, time-locked to probe onset. Trials with ocular, muscular, or other artifacts, as well as erroneous trials in either probe or search task, were excluded from analysis on the basis of the same criteria as in the first type of analysis. Probe-absent trials were subtracted from probe-present trials, which allowed for elimination of overlapping potentials related to search display presentation and for the extraction of potentials related to probe presentation. The subtraction was conducted on epoched data, separately for each search display type and each SOA, time-locked to probe onset. The EEG signal was averaged for “one-singleton” displays with regard to two probe positions (“On,” i.e., the previous position of a

**Figure 2.** Trial sequence. Participants were asked to detect a predefined target (a circle) in a search array. Subsequent to search display presentation, a probe stimulus appeared after a variable SOA. Participants were asked to first respond with one hand to the probe task (that is, detect the probe presence) and only then to respond with the other hand to the search task (that is, respond whether there was the target present or not). In case of an incorrect answer either to the probe task or to the search task, a verbal feedback appeared on the screen for 500 msec followed by a 500-msec blank screen.

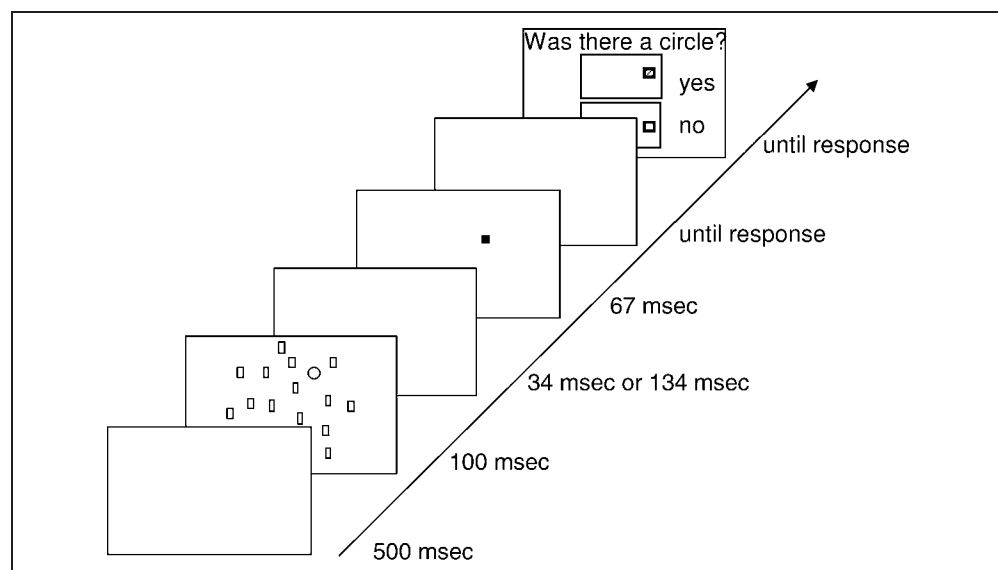

singleton vs. “Off,” i.e., the previous position of a neutral distracter) and two SOAs (short vs. long). Note that the “On” position represented previous target positions in the target-present displays and previous irrelevant singleton positions in the irrelevant-singleton displays. For “both singletons” displays, the EEG signal was averaged for three probe positions (“On”-target, “On”-irrelevant singleton, and “Off”) and also two SOAs. In this way, 14 ERP waveforms were obtained for each participant and each electrode. Subsequently, for all display types, EEG waveforms elicited by the “Off” condition were subtracted from the “On” condition, which reduced the number of waveforms to eight difference waves (four for each SOA). Mean amplitudes obtained in the P1 time window (100–170 msec poststimulus onset) were subject to repeated measures ANOVAs on the difference waves of the “Off” condition subtracted from the “On” condition for the electrode sites PO3, PO4, POz, PO7, PO8, O1, O2, and Oz with the factors SOA (long vs. short), display type (one singleton vs. both singletons), task relevance (target vs. irrelevant singleton), and electrode (PO3, PO4, POz, PO7, PO8, O1, O2, and Oz).

### Behavioral Data

Mean RTs and error rates were computed for each participant in both the search and the probe detection tasks. Prior to the analysis of RT data in the probe task, errors in any of the two tasks as well as outliers in the probe task were excluded from further analysis ( $\pm 2$  SD from the overall mean RT for each participant separately). Prior to the analysis of the error rates in the probe task, trials with errors and outliers in the search task were excluded. Individual mean RTs and errors for probe-present trials were then split into the “On” and “Off” conditions for each display type and each SOA separately. Mean RTs and mean error rates in displays with one-singleton were subsequently submitted to a  $2 \times 2 \times 2$  repeated measures ANOVA with SOA (short vs. long), task relevance (target vs. irrelevant singleton), and position (“On” vs. “Off”) as within-subject factors. A separate analysis was conducted for the condition with displays containing both singletons with SOA (short vs. long) and position (“On”-target vs. “On”-irrelevant singleton vs. “Off”) as within-subject factors. Note that in this condition, the position factor included the task relevance factor because probes could be presented at the positions: “On”-target, “On”-irrelevant singleton, or “Off.”

## RESULTS

### ERP Results

#### ERPs Locked to Search Display Onset

The analysis performed for the mean amplitudes of the P2 component showed that, in this time window (180–230 msec), ERPs elicited by the various display types dif-

fered significantly [ $F(3, 57) = 11.7, p < .001$ ]. Planned comparisons revealed that target trials ( $M = -0.6 \mu\text{V}$ ,  $SEM = 0.5$ ) did not differ from irrelevant singleton trials ( $M = -0.6 \mu\text{V}$ ,  $SEM = 0.6$ ),  $p > .6$ . Only the blank trials evoked a more negative mean amplitude ( $M = -1.2 \mu\text{V}$ ,  $SEM = 0.6$ ) and were significantly different from target trials [ $F(1, 19) = 8.1, p = .01$ ]. Trials with displays containing both singleton types evoked a more positive mean amplitude relative to other trials ( $M = -0.1 \mu\text{V}$ ,  $SEM = 0.5$ ) and differed significantly from target trials [ $F(1, 19) = 12, p < .005$ ] (see Figure 3, box on the left). Analogous analysis performed for the mean amplitudes obtained in the N2 time window (230–300 msec) also showed a significant difference for the various search display types [ $F(3, 57) = 16, p < .001$ ]. Planned comparisons revealed that in that later time range, trials with target displays elicited a more positive amplitude ( $M = -0.2 \mu\text{V}$ ,  $SEM = .6$ ) relative to irrelevant singleton trials ( $M = -1 \mu\text{V}$ ,  $SEM = 0.6$ ) [ $F(1, 19) = 10, p < .01$ ]. In this time window, target trials evoked a more positive amplitude also relative to blank trials ( $M = -1.7 \mu\text{V}$ ,  $SEM = 0.6$ ) [ $F(1, 19) = 20, p < .001$ ], but did not differ from the trials containing displays with both singletons ( $M = -.02 \mu\text{V}$ ,  $SEM = .6$ ),  $p > .3$  (see Figure 3, box on the right).

#### N2pc Analyses Time-locked to the Search Display

The N2pc analysis showed a significantly more negative N2pc elicited by the target ( $M = -0.6 \mu\text{V}$ ,  $SEM = 0.1$ ) compared to the N2pc elicited by the irrelevant singleton ( $M = 0.02 \mu\text{V}$ ,  $SEM = 0.1$ ) [ $F(1, 19) = 25, p < .001$ ; see

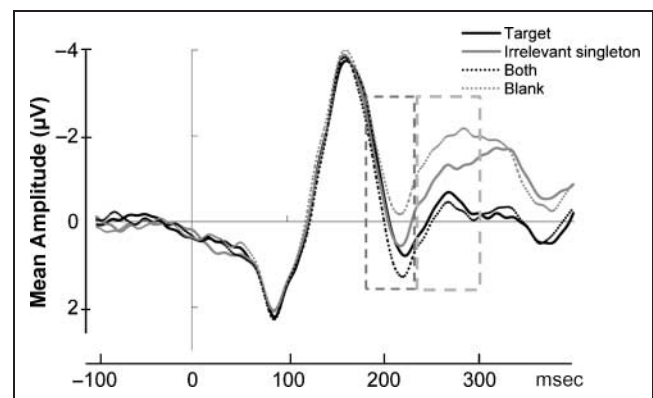

**Figure 3.** Grand averages of the EEG signal pooled across the O1, O2, Oz, PO7, PO8, POz, PO3, and PO4 electrodes, time-locked to search display onset. The solid black line represents target displays, the solid gray line represents displays with irrelevant singleton, the dotted black line reflects displays containing both singletons and the dotted gray line stands for blank displays. The box on the left (dark gray, dashed) represents the earlier time window (180–230 msec), whereas the box on the right (lighter gray, dashed) represents the time window between 230 and 300 msec. Note that the baseline started 200 msec prior to display presentation onset and that the statistical analysis was conducted on unfiltered data. High cutoff (30 Hz) filters have been applied to grand averages only for illustration purposes.

Figure 4A]. This difference was observed when singletons were presented as the only singletons in the display as well as when both were presented simultaneously, as indicated by a nonsignificant interaction of task relevance (target vs. irrelevant singleton) and display type (one-singleton vs. both),  $p > .25$ . The N2pc evoked by targets and irrelevant singletons was subsequently tested against zero, showing a significant N2pc for targets [ $t(19) = 6$ ,  $p < .001$ , two-tailed], but not for irrelevant singletons ( $p > .75$ , two-tailed).

To gain further insight into the allocation of attention in the condition when both target and irrelevant singleton were presented in the same display, these trials were split into two categories: both singletons in the same hemifield versus target and irrelevant singleton in opposite hemifields (for a similar procedure, see Hickey et al., 2006). The N2pc was calculated relative to the target item. Splitting this condition into the two above categories resulted in two N2pc waves: a target N2pc accompanied by an irrelevant singleton in the same hemifield (see Figure 4B, solid line) and a target N2pc accompanied by an irrelevant singleton in the opposite hemifield (see Figure 4B, dotted line). An ANOVA on the mean amplitudes obtained in the earlier window of the N2pc deflection (180–240 msec) revealed that the N2pc was larger when the target and the irrelevant singleton were presented in the same hemifield ( $M = -1 \mu\text{V}$ ,  $SEM = 0.1$ ) compared to when they were presented in opposite hemifield ( $M = -0.4 \mu\text{V}$ ,  $SEM = 0.1$ ) [ $F(1, 19) = 7$ ,  $p < .05$ ; see Figure 4B, the “N2pc<sub>a</sub>” box]. A second ANOVA on the mean amplitudes obtained in the later N2pc window (240–300 msec) showed no differences with respect to whether the irrelevant singleton was located in the same hemifield

( $M = -0.74 \mu\text{V}$ ,  $SEM = 0.2$ ) or in the opposite hemifield ( $M = -0.7 \mu\text{V}$ ,  $SEM = 0.2$ ),  $p > .8$  (see Figure 4B, the “N2pc<sub>b</sub>” box).

#### ERPs Locked to Probe Onset

The analysis on subtracted (“On” – “Off”) P1 mean amplitudes showed that for the long SOA, ERPs evoked by probes following targets differed significantly from probes following irrelevant singletons, whereas at the short SOA, these two conditions yielded similar effects, as indicated by the interaction between SOA and task relevance [ $F(1, 19) = 6$ ,  $p < .05$ ]. This pattern of results was not affected by the display type (one singleton vs. both), as the three-way interaction between task relevance, SOA, and display type was not significant ( $p > .7$ ). Subsequent analysis on the long SOA only, showed that the difference in P1 mean amplitude between “On” and “Off” conditions was significantly larger for target trials ( $M = 0.7 \mu\text{V}$ ,  $SEM = 0.2$ ) relative to irrelevant singleton trials ( $M = 0.1 \mu\text{V}$ ,  $SEM = 0.2$ ) [ $F(1, 19) = 8$ ,  $p < .05$ ; see Figure 5, left]. At the short SOA, ERPs elicited by probes following targets ( $M = 0.32 \mu\text{V}$ ,  $SEM = 0.2$ ) did not differ from ERPs evoked by probes following irrelevant singletons ( $M = 0.36 \mu\text{V}$ ,  $SEM = 0.1$ ;  $p > .8$ ; see Figure 5, right). The “On” – “Off” differences for target and irrelevant singleton positions at the long SOA were subsequently tested against zero, showing an effect for target positions [ $t(19) = 3$ ,  $p < .01$ , two-tailed], but not for irrelevant singleton positions ( $p > .35$ , two-tailed). The ANOVA conducted on mean amplitudes in the N1 time window (180–230 msec) showed no significant effects (all  $p$  values  $> .1$ ).

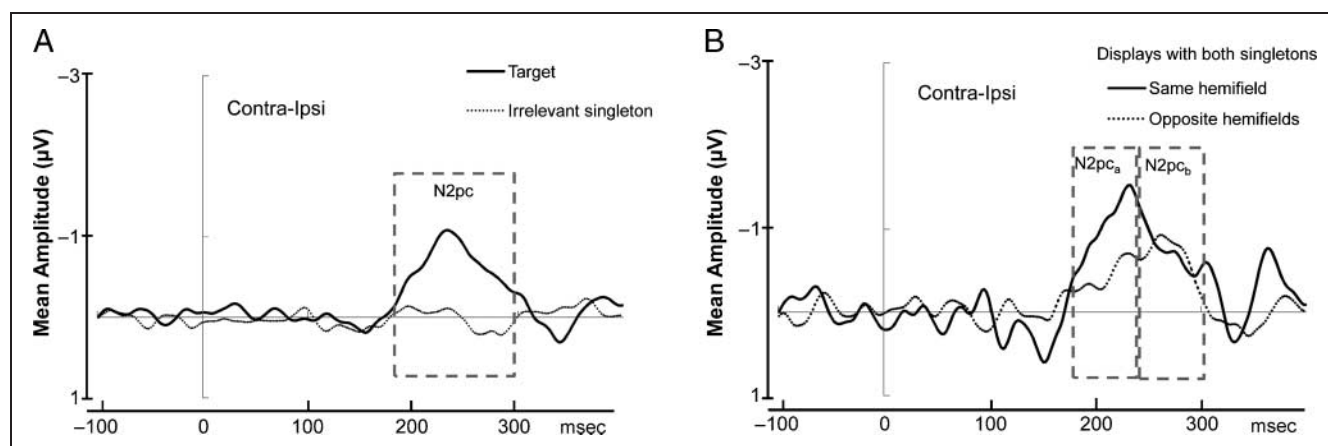

**Figure 4.** Grand averages of the difference waves measured as ipsilateral site subtracted from contralateral site pooled across O1/O2, PO7/PO8, and PO3/PO4 electrodes, time-locked to search display onset. (A) The contralateral–ipsilateral difference wave measured relative to the target (black line) and irrelevant singleton (dotted line) averaged across displays with one singleton and both singletons. (B) The contralateral–ipsilateral difference wave for displays containing both singletons measured relative to the target. The black line represents the condition when the irrelevant singleton was presented in the same hemifield as the target, the dotted line represents the condition when target and irrelevant singleton were presented in opposite hemifields. The rectangular area on the left (N2pc<sub>a</sub>) represents the earlier time window (180–240 msec), whereas the area on the right (N2pc<sub>b</sub>) represents the time window between 240 and 300 msec. Note that the baseline started 200 msec prior to display presentation onset and that the statistical analysis was conducted on unfiltered data. High cutoff (30 Hz) filters have been applied to grand averages only for illustration purposes.

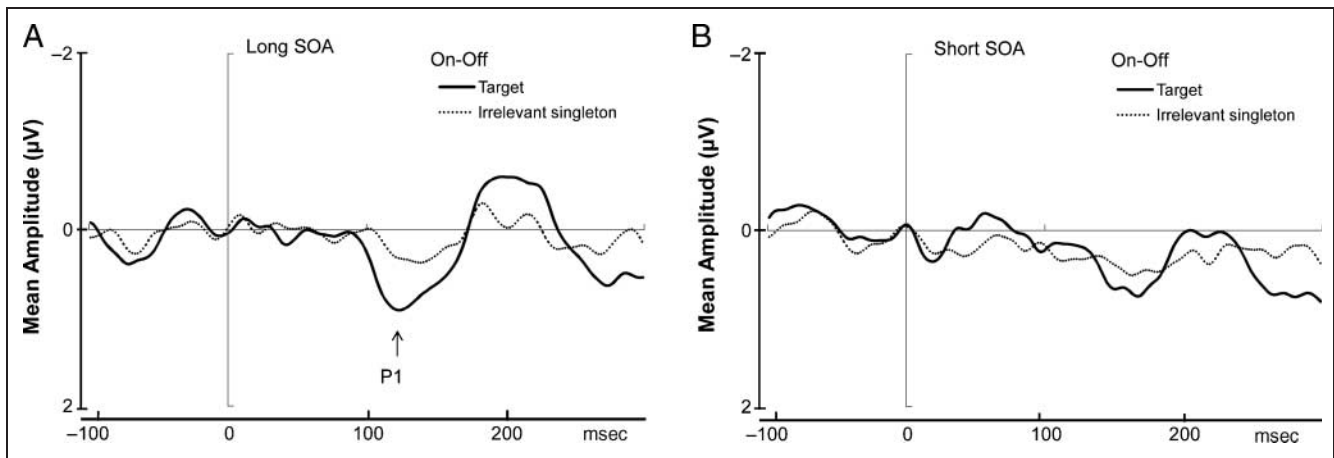

**Figure 5.** Grand averages of the difference waves measured as the EEG signal to the “Off” condition subtracted from the “On” condition, time-locked to probe onset, and pooled across O1, O2, Oz, PO7, PO8, POz, PO3, and PO4 electrodes. Differences between the “On”-target condition and the “Off” condition (black lines) as well as between “On”-irrelevant singleton condition and the “Off” condition (dotted lines) averaged across displays with one singleton and both singletons. (A) Long SOA condition; (B) Short SOA condition. Note that the baseline started 200 msec prior to probe presentation onset and that the statistical analysis was conducted on unfiltered data. High cutoff (30 Hz) filters have been applied to grand averages only for illustration purposes.

## Behavioral Data

### Reaction Times in the Probe Task

An overview of mean RTs is given in Table 1. The analyses performed on mean RTs showed no significant effects of position (“On” vs. “Off”) in either one-singleton displays or displays with both singletons (“On”-target vs. “On”-irrelevant singleton vs. “Off”). Only a main effect of task relevance was obtained for one-singleton displays, showing faster RTs for probes following target displays ( $M = 444$  msec,  $SEM = 25$ ) relative to irrelevant singleton displays ( $M = 471$  msec,  $SEM = 26$ ) [ $F(1, 19) = 43, p < .001$ ]. No other factors reached significance (all  $p$  values  $> .1$ ; see Figure 6, left). For displays containing both singletons, only the SOA factor reached significance, showing faster RTs to probes at the long SOA ( $M = 439$  msec,  $SEM = 23$ ) compared to the short SOA ( $M = 453$  msec,  $SEM = 24$ ) [ $F(1, 19) = 9.6, p < .01$ ].

### Error Rates in the Probe Task

Table 2 (left) presents an overview of error rates in the probe detection task. Additionally, error rates in the target detection task are presented in Table 2 (right). The analysis performed on mean error rates in the probe task for displays with one singleton revealed a main effect of task relevance [ $F(1, 19) = 12, p < .005$ ], indicating lower error rates for probes following target displays ( $M = 4.4\%$ ,  $SEM = 0.7$ ) compared to irrelevant singleton displays ( $M = 7.2\%$ ,  $SEM = 1.1$ ), and a significant interaction of position, SOA (short vs. long), and task relevance (target vs. irrelevant singleton) [ $F(1, 19) = 6.6, p < .05$ ; see Figure 6, right]. When displays contained both singletons, a main effect of position (“On”-target vs. “On”-irrelevant vs. “Off”) was observed [ $F(2, 38) = 7, p < .005$ ], indicating that the “On”-target position yielded fewer

errors ( $M = 2.6\%$ ,  $SEM = 0.6$ ) than the “On”-irrelevant singleton position ( $M = 5\%$ ,  $SEM = 0.7$ ) [ $F(1, 19) = 11.7, p < .005$ ], and fewer errors than the “Off” position ( $M = 5.1\%$ ,  $SEM = 1$ ) [ $F(1, 19) = 9, p < .01$ ].

Further analyses were conducted to compare the effects of probe positions across two display types (one singleton vs. both). As error rates revealed similar effects but less variability than RTs (see Figure 6), these analyses were conducted on error rates rather than on RT. Similar to

**Table 1.** Mean Reaction Times and Standard Errors (in Brackets) in the Probe Detection Task for Probe-present Trials (Four Upper Rows) as a Function of SOA and Trial Type and for Probe-absent Trials (Four Lower Rows) as a Function of Trial Type

Trial Type	Mean RTs (msec) and SE (in Brackets)	
	Short SOA	Long SOA
<i>Probe-present Trials</i>		
Target	457 msec (27)	435 msec (23)
Irrelevant singleton	474 msec (28)	471 msec (24)
Both singletons	455 msec (24)	440 msec (22)
Blank	473 msec (26)	474 msec (26)
<i>Probe-absent Trials</i>		
Target	601 msec (35)	
Irrelevant singleton	515 msec (25)	
Both singletons	606 msec (35)	
Blank	506 msec (28)	



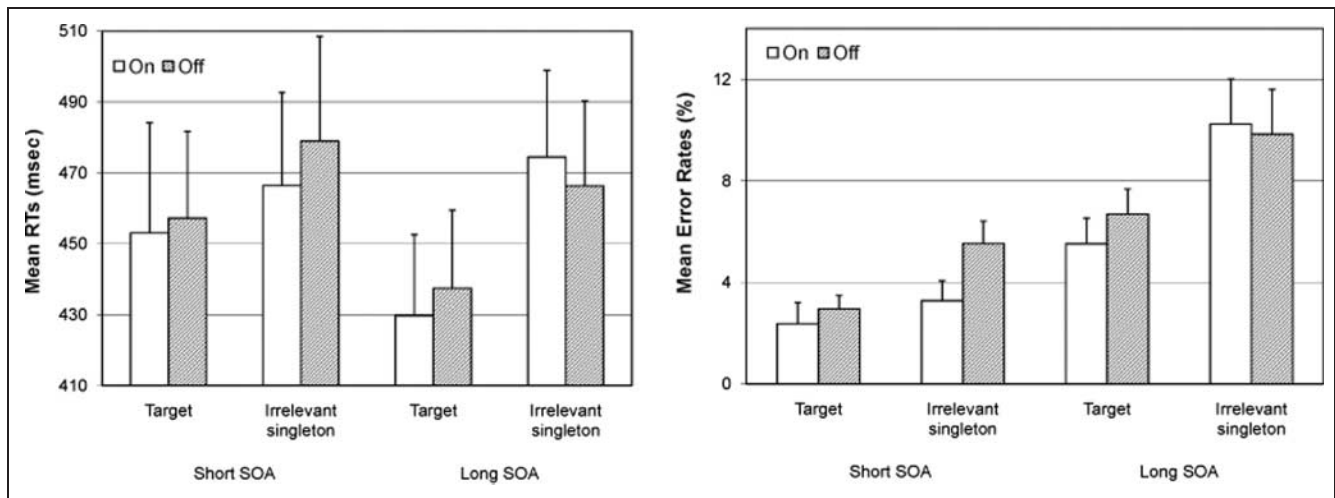

**Figure 6.** Mean reaction times (left) and error rates (right) in the probe detection task. Results are shown for probes that followed search displays with one singleton (target displays or irrelevant distractor displays) after a short (134 msec) or a long (234 msec) SOA. Empty bars depict performance to probes presented at former singleton locations (“On” target, “On” irrelevant singleton). Filled bars show performance to probes presented at former neutral distracter locations (“Off” positions). Error bars represent standard errors of the mean.

computations performed on probe-locked ERPs, a repeated measure ANOVA was conducted on differences between mean error rates in “On” and “Off” conditions across both display types with SOA (short vs. long), display type (one singleton vs. both singletons), and task relevance (target vs. irrelevant singleton) as within-subject fac-

tors. As mean error rates in the “Off” condition were subtracted from mean error rates in the “On” condition, negative values indicate that fewer errors were made for probes “On” singleton positions compared to probes “Off” singleton positions. Results showed a general benefit for “On” positions over the “Off” position that was modulated by SOA and display type [ $F(1, 19) = 5, p < .05$ ; cf. Figure 7]. Further analyses showed a larger benefit for the target position ( $\Delta_{\text{Error Rates}} = -1.6\%$ ,  $SEM = 0.8$ ) than for the irrelevant singleton position ( $\Delta_{\text{Error Rates}} = 0.2\%$ ,  $SEM = 0.7$ ) in the long SOA condition [ $F(1, 19) = 6$ ,

**Table 2.** Mean Error Rates and Standard Errors (in Brackets) in the Probe Detection Task (Left) and Target Detection Task (Right) for Probe-present Trials (Four Upper Rows) as a Function of SOA and Trial Type and for Probe-absent Trials (Four Lower Rows) as a Function of Trial Type

Trial Type	Mean Error Rates (%) and SE (in Brackets)			
	Probe Detection Task		Target Detection Task	
	Short SOA	Long SOA	Short SOA	Long SOA
<i>Probe-present Trials</i>				
Target	3% (0.6)	6% (1)	5% (1)	3% (1)
Irrelevant singleton	5% (0.8)	10% (2)	3% (0.6)	2% (0.5)
Both singletons	3% (0.6)	6% (1)	6% (1)	3% (0.6)
Blank	5% (1)	10% (2)	3% (0.5)	3% (0.7)
<i>Probe-absent Trials</i>				
Target	12% (2)		2% (0.5)	
Irrelevant singleton	5% (1)		2% (0.7)	
Both singletons	13% (2)		2% (0.4)	
Blank	4% (1)		2% (0.6)	

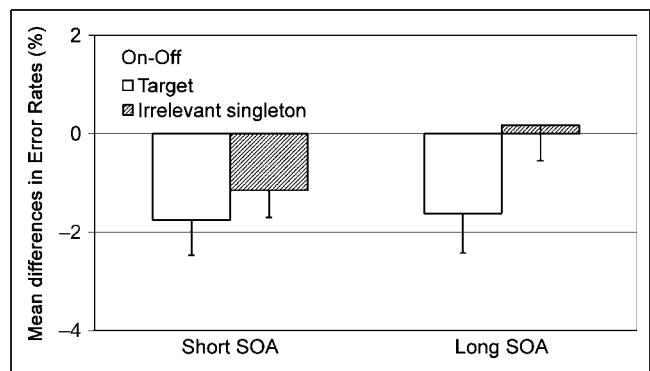

**Figure 7.** Mean differences of error rates in the probe detection task calculated through subtraction of mean error rates in the “Off” condition from mean error rates in the “On” condition. Differences between the “On”-target condition and the “Off” condition (empty bars) as well as between the “On”-irrelevant singleton condition and the “Off” condition (filled bars) were averaged across displays with one singleton and both singletons for short SOA (left) and long SOA (right). Negative values mean that less errors in probe detection were committed when the probe appeared at the “On” position compared to the “Off” position, whereas positive values mean that more errors were committed for the “On” condition than for “Off” condition. Error bars represent standard errors of the mean.

$p < .05$ ]. For short SOAs condition, no difference in the benefit for “On”-target and “On”-irrelevant singleton was observed ( $p > .35$ ).

## DISCUSSION

In the present paradigm, participants were instructed to perform two tasks. The first was a visual search task, that is, participants were asked to detect a blue circle target among blue rectangular distracters. The search display could contain either only the target (target display), the target plus an irrelevant salient singleton (display with both singletons), an irrelevant singleton only (irrelevant singleton display), or, finally, no singletons (blank display). In the second task, participants had to detect, as fast as possible, a blue square probe that appeared subsequent to the search display with a variable SOA (134 or 234 msec). The probe was presented at a position of either one of the singletons (“On” position) or at a position of one of the neutral distracters (“Off” position). Two SOAs were introduced to investigate the time course of attention allocation to items of the search display.

An assumption in the present paradigm was that the irrelevant (color) singleton was more salient than the (shape) target. This implied that that attention allocated to the target would indicate top-down control, whereas attention allocated to the irrelevant (but more salient) singleton would suggest bottom-up driven capture. However, if the irrelevant singleton was not more salient than the target, any benefits of the target over the irrelevant singleton might not be due to the top-down modulation related to task relevance but, rather, its bottom-up, saliency signal. In order to test whether the color-irrelevant singleton was, indeed, more salient than the shape target, a behavioral control experiment was conducted with the search task being the same as in the original experiment. Target displays, displays with irrelevant singletons, displays with both singletons, and blank displays were presented for 100 msec. Participants were to respond with one key when the target was present (target displays and displays with both singletons) and with another key when it was absent (blank displays and irrelevant singleton displays). There was no probe task involved. Target assignment changed after half of the trials. In the first half, the target was defined by one dimension (e.g., shape), whereas in the second half it was defined by the other dimension (e.g., color). The order of target assignment was counterbalanced across participants. If the color singleton was indeed more salient than the shape singleton, RTs to color targets should be faster than RTs to shape targets. Moreover, if color is more salient than shape, rejection of color as irrelevant should take longer than rejection of shape, as a stronger saliency signal should interfere more with the relevant target. A  $2 \times 2$  ANOVA with the factors task relevance (target vs. irrelevant) and singleton type (shape vs. color) showed that responses to color targets were faster ( $M = 289$  msec,  $SEM = 7$ ) than responses

to shape targets ( $M = 302$  msec,  $SEM = 10$ ), whereas rejection of color singletons ( $M = 319$  msec,  $SEM = 12$ ) was slower than rejection of shape singletons ( $M = 301$  msec,  $SEM = 8$ ) as indicated by an interaction of task relevance and singleton type [ $F(1, 17) = 4.8, p < .05$ ; see Figure 8]. Thus, in the present design, color singletons were indeed more salient than shape singletons.

As argued above, if attention is guided to the relevant target in a top-down manner, ERPs elicited by the target items should show a benefit over ERP responses to irrelevant singletons. Such a benefit might be observed relatively late as top-down control seems to take time (see, e.g., Van Zoest et al., 2004; Theeuwes et al., 2000; Kim & Cave, 1999). The question remains whether the earlier, bottom-up driven processing can be modulated by top-down control as, for instance, Müller et al. (2003) postulate. If so, neural responses to the more salient singleton should be modulated (i.e., suppressed) through top-down mechanisms. Therefore, no benefit of the (more) salient singleton should be observed in the ERPs in either early or late time intervals.

Results of the present study showed a more positive ERP waveform for target trials relative to irrelevant singleton trials in the time window of the N2 component, that is, after 230 msec postdisplay presentation (see Figure 3). Although this shows that top-down control of focal attention was fully in power only after 230 msec, no enhanced processing of the more salient irrelevant singleton was found in the earlier time window of the P2 component (180–230 msec postdisplay presentation; see Figure 3). This speaks in favor of some modulatory influence of top-down control over the saliency-based bottom-up processing: The irrelevant singleton did not elicit a stronger neural response than the target, although the former was more salient than the latter. Therefore, no “saliency benefit” was observed for the irrelevant singleton in this early time window.

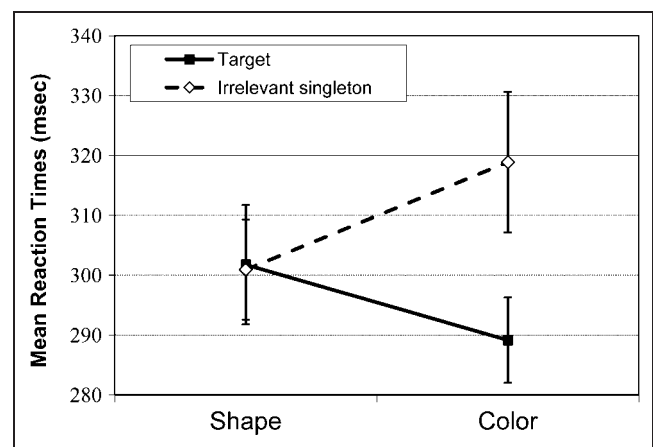

**Figure 8.** Results of the control experiment. Reaction times to targets (solid line) and irrelevant singletons (dashed line) as a function of singleton type: shape (left) versus color (right). Error bars represent standard errors of the mean.

At this stage of processing, only neural responses to blank displays and to displays with both singletons differed significantly from responses to trials containing one of the singletons (see Figure 3). Distinct processing of the two “extreme” cases (no saliency signals in blank trials and saliency signals on two dimensions in the display with both singletons) might suggest that, first, the system sorted the display types into rough categories based on singleton presence. The most and the least homogeneous displays were distinguished based on what one might call “homogeneity detectors”: Schubö, Wykowska, and Müller (2007) and Schubö, Schröger, and Meinecke (2004) showed that distracter rejection in blank trials is reflected by an enlarged posterior N2 (similar time window as in the present P2 effects, i.e., 200–300 msec) for homogeneous distracter displays, probably reflecting fast global processing mechanisms, such as perceptual grouping (e.g., Duncan & Humphreys, 1989). Distinct processing of blank displays and displays containing both singletons compared to the intermediate case of one-singleton displays might suggest that at early stages of processing, the system operated at the global level of homogeneity detection. However, neither at this stage nor at any earlier stage of processing did the more salient irrelevant singleton elicit more enhanced neuronal response compared to the less salient target item.

Further evidence for top-down control of attention allocation was obtained through analysis of the N2pc component. N2pc was observed for the target item but not for the irrelevant singleton (see Figure 4A, solid and dotted lines, respectively). This suggests that attention was efficiently allocated to the target and was not attracted by the irrelevant salient item even in cases when a more salient singleton was presented in the same display together with the target. However, a closer look at the condition when both the target and the irrelevant singleton appeared simultaneously in the same display revealed that first (between 180 and 240 msec postdisplay presentation), the N2pc was more enhanced in the condition when both singletons were presented in the same hemifield compared to when they were presented in opposite hemifields (see Figure 4B, box on the left). Only later (240–300 msec postdisplay presentation) was N2pc in these conditions the same (see Figure 4B, box on the right). This result might suggest that attention allocation to the target was, to some extent, affected by the salient-irrelevant singleton that was presented together with the target. The irrelevant singleton may have attracted attention in some trials, although in most cases, attention was allocated to the target, as a target-related N2pc was still observed. Moreover, no “reversed polarity” was found for the N2pc in these trials (see Hickey et al., 2006), indicating that in most of the trials, attention has not been allocated to the irrelevant singleton.<sup>2</sup>

Finally, ERPs time-locked to probe onsets also provided converging evidence for top-down control of focal attention. If attention was allocated to the target prior to probe presentation, probe processing should be enhanced for

probes presented at target locations (“On”-target) compared to probes presented at locations of one of the neutral distracters (“Off”). Analogously, if attention was attracted to the irrelevant singleton through bottom-up mechanisms, probe processing should be enhanced for probes presented at irrelevant singleton locations (“On”-irrelevant singleton) compared to the locations of one of the neutral distracters (“Off”). The present results showed that the benefit of the “On”-target position was significantly larger compared to the benefit of the “On”-irrelevant singleton position in the long SOA condition (see Figure 5, left). Importantly, this difference was obtained when the (identical) probe item was presented after the same time interval relative to search display onset. Therefore, this effect should reflect a difference in internal probe processing caused by differences in the allocation of attention to the search display that was preceding probe presentation. Such a positive deflection within this early time window observed at posterior electrodes is usually associated with the P1 component (see Luck, 2005 for a review). The P1–N1 complex has been interpreted as an indicator of spatial attention (Luck et al., 1993, 2000; Hillyard et al., 1998; Mangun et al., 1993). Therefore, an enhanced P1 for the probe when presented at the former target location indicated that attention had been deployed to that location before probe onset and once another stimulus (namely, the probe) appeared there, its processing was facilitated. However, the top-down guidance took time as in the short SOA condition, no benefit of the target position was observed. Interestingly, also no benefit of the irrelevant singleton position relative to the neutral positions was observed at the short SOA (see Figure 5, right). This might show converging evidence for the top-down modulatory mechanism that did not allow for attention to be allocated to the irrelevant singleton although it was the most salient item in the visual field.

Behavioral results also showed evidence for top-down control of attention allocation. Again, the logic goes as follows: If attention was allocated to the target prior to probe presentation, a benefit (e.g., lower error rates) should be observed for probes presented at target locations (“On”-target) compared to probes presented at locations of one of the neutral distracters (“Off”). Analogously, if attention was attracted to the irrelevant singleton, fewer errors should be made for probes presented at irrelevant singleton locations (“On”-irrelevant singleton) compared to the locations of one of the neutral distracters (“Off”). Therefore, the larger the difference in error rates between the “On” and “Off” condition, the more beneficial the “On” position was. The present results showed a general benefit of the target position over the neutral distracter positions in error rates in the probe task (see Figure 7, empty bars). This supports the ERP evidence for the top-down control of focal attention. Moreover, at the long SOA, probes presented at the irrelevant singleton position yielded more errors than at the neutral (“Off”) locations (see Figure 7, right). This might suggest a suppression mechanism (top-down

controlled) with respect to the irrelevant singleton. When the irrelevant singleton was presented, the system tried to suppress its strong saliency signal as task-irrelevant and when a probe appeared subsequently at the “suppressed” location, it was harder to detect than when presented at one of the neutral distracter locations. Furthermore, top-down modulatory effects were also observed at the short SOA: Although there was some benefit of the irrelevant singleton position in this condition (see Figure 7, filled bar on the left), this benefit was not larger than the benefit of the target’s position (see Figure 7, empty bar on the left). This parallels the effects observed for the N2pc component locked to search displays, and suggests that bottom-up mechanisms that are operating at the early stages of processing are, to some extent, penetrable by top-down control. RT data showed a similar pattern as error rates although RT position effects did not reach significance (cf. Figure 6). In summary, the behavioral results show some traces of irrelevant singleton selection in the short SOA condition that was completely overridden by top-down control at the long SOA. This might parallel the N2pc results, suggesting that the irrelevant singleton had some effect on target selection in the earlier stages.

### Top-Down Mechanism of Target Selection

Results of the present study clearly showed that with time, top-down control of selection was capable of efficiently guiding focal attention to the relevant target although its saliency level was lower than the saliency level of the irrelevant singleton. After ca. 230 msec, the target item elicited a more positive P2 component compared to the irrelevant singleton. This might suggest that at this stage, the target item was already assigned prioritized processing which allowed for its selection in accordance to task instructions. Converging evidence from the analyses of the N2pc component, probe-locked ERPs, and error rates showed that, around that time point, attention was already efficiently allocated to the relevant target regardless of the presence of a more salient singleton, even if presented simultaneously.

Interestingly, this evidence for top-down modulation was observed in the case of a simple feature search task. Moreover, as the target was less salient than the irrelevant singleton, target-related effects on ERPs can be attributed to a top-down mechanism. Therefore, one can conclude that even search for popout might be top-down modulated. Such results support a standpoint of, for example, Müller et al. (2003) or Wolfe et al. (2003).

### Suppression of Irrelevant Bottom-Up Activity

Proponents of a “pure capture” stance claim that at early stages of processing, saliency signals are computed and focal attention is guided to items of the visual field in the order of their decreasing saliency. Theeuwes et al. (2006) and Theeuwes (1992) argue that such a bottom-

up driven mechanism of allocating attention to the most salient item in the field is mandatory and impenetrable to top-down control. Therefore, if a target is accompanied by a singleton that is more salient, the mere presence of such a singleton interferes with target selection. The present study, however, shows that bottom-up saliency-based processing is penetrable to top-down control. Not only did the present results show efficient selection of the target item guided by top-down control but they also revealed that bottom-up driven neural activation related to the more salient irrelevant singleton was modulated by top-down mechanisms.

In the present experiment, two singletons with unequal saliency values were presented. The more salient singleton was defined as irrelevant to the task. Therefore, in line with the dimensional weighting account (e.g., Müller et al., 1995; Müller et al., 2003), we assumed that in order to efficiently select the less salient item, participants had to presumably suppress the strong saliency signals elicited by the irrelevant singleton. Such a suppression mechanism should allow the less salient target to win the competition for selection against the more salient singleton. The present results show that the neural responses to the irrelevant singleton were most probably suppressed: A pronounced N2pc was observed for the target item *but not* for the irrelevant singleton. Also, early ERP components showed no signs of enhanced neural activity in response to presentation of the irrelevant singleton. This might mean that top-down control presumably acted on the bottom-up driven activation in such a way as to inhibit the strong response related to the more salient but irrelevant singleton. Moreover, although the results of error rates showed some benefit of the “On”-irrelevant singleton position at the short SOA (see Figure 7, left, filled bar), it was not larger than the benefit of the “On”-target position (see Figure 7, left, empty bar). This behavioral effect shows traces of early bottom-up effects. It also speaks for some influence of the top-down mechanism on bottom-up attentional capture as the position of the more salient singleton did not exhibit larger benefits than the position of the less salient target. These results suggest that top-down control was capable of limiting attentional capture even at the stage when processing is strongly affected by saliency signals (e.g., Van Zoest et al., 2004; Theeuwes et al., 2000).

It is interesting to note that the error rates showed early bottom-up effects that were not clearly observed in the ERP data. It might be the case that the attentional capture reflected by the present behavioral data, as well as in the results of Kim and Cave (1999), indicates effects accumulated across the whole processing stream, whereas ERPs mirror particular stages where attentional capture has not occurred. Alternatively, one might argue that the short SOA was still too long to pinpoint the early bottom-up effects in the probe-locked ERP data (see, e.g., Theeuwes et al., 2000). However, as the search-locked ERPs also did not show attentional effects related to the irrelevant singleton, the early bottom-up effects may as

well have just been attenuated. This could be due to the design that might have encouraged a strategy of target selection that was not based solely on the detection of any salience. Although the present design cannot circumvent the possibility of applying a bottom-up strategy in target selection to some extent as both singletons were salient and also might have been informative with respect to the subsequent probe position, the design puts some limits on such a bottom-up strategy. The target-only displays and irrelevant singleton-only displays should have encouraged participants to search for the target-defining feature in order to distinguish it from the irrelevant color feature. Hence, a pure bottom-up strategy could not have been sufficient. Encouraging a more top-down strategy in target selection might also be a reason for why the top-down mechanism showed modulatory influences on processing, whereas the bottom-up effects were not observed in the ERPs.

The present results are in line with a recent study of Lien et al. (2008). Lien et al. used a cueing paradigm that Folk and Remington (1998) and Folk et al. (1992) applied earlier. In their paradigm, a task-irrelevant cue was presented before the target display. The authors observed contingent capture effects: Attention was captured to the cue (cue validity effects) only if it shared target characteristics (i.e., same color). Importantly, for the purposes of the present study, the authors observed contingent capture effects not only in behavioral data (as in the previous studies of Folk and colleagues) but also in form of N2pc modulations. Moreover, there was no sign of attentional capture to a salient stimulus that did not share the characteristics of the target. Lien et al. concluded that attention is not captured by a salient item when the item does not share characteristics of the target and, as such, does not fall into observers' prespecified attentional set.

Taken together, the present evidence as well as the results of Lien et al. (2008) speak against the "pure capture" perspective which postulates that attention is first *necessarily* driven to the most salient items in the visual field irrespective of their relevance and only then can be engaged to the items which are less salient but task-relevant. The present results show that the focus of attention can be controlled in a top-down manner already at the early stages of processing.

### **Temporal Dynamics between the Bottom-Up Mechanisms and Top-Down Control of Selection**

An important goal of the present study was to examine the temporal dynamics of top-down control of visual selection. Although top-down modulatory influences on the bottom-up driven processes were already found in other studies (e.g., Lamy et al., 2003; Müller et al., 2003), the ERP methodology applied in the present experiment allowed for precise identification of the temporal interplay of top-down and bottom-up selection processes prior to response execution. Results obtained in the present ERP

measures illustrate the dynamics of the mechanisms involved in attention guidance. Such a picture could not be obtained solely with behavioral measures when only end-effects of the processing stream can be measured, namely, responses to the task. The present results showed attention allocation to the target item already after 180 msec and no such effect for the irrelevant singleton (N2pc), which speaks in favor of a strong top-down influence on bottom-up processing. Although the irrelevant salient item did affect, to some extent, target selection in cases when it was presented in the same display as the target (the N2pc relative to the target was more pronounced when the irrelevant singleton was presented in the same hemifield compared to when it was presented in the opposite hemifield), top-down control was potent enough to guide attention to the relevant target item (the target elicited an N2pc irrespective of whether it was presented as the only singleton in the display or together with the irrelevant singleton in the "both" condition). Probe-locked ERPs and error rates revealed that with time, attention is allocated to the relevant target but not to the irrelevant singleton (benefit of the "On"-target position and not of the "On"-irrelevant singleton position at the long SOA).

The present results support a view on visual selection that is in line with, for example, the dimension weighting account of Müller et al. (1995, 2003) and Found and Müller (1996) (see also Wolfe et al., 2003; Wolfe, 1994 for a similar account). This view postulates that the visual scene is represented in separate, dimension-specific "maps," such as color or orientation. Saliency signals are transmitted from these maps to a priority map (Yantis & Jones, 1991), where the weighted sum of activation signals is computed. Focal attention is then guided to locations on the priority map with the order of decreasing levels of activation. In this model, top-down processes can have an influence on the activation signals at the priority map by weighting task-related or otherwise relevant dimensions higher than irrelevant dimensions. Although the most salient item in the visual field yields a strong activation signal, a less salient dimension that has been weighted higher (i.e., due to its relevance) might result in an even stronger activation because a *weighted* sum of activation signals is computed at the priority map. Weighting might take place through enhancement of signals on the relevant dimension and/or through suppression of signals on the salient but irrelevant dimension.

Although the exact interpretation of the present results in the context of such a theoretical perspective requires further investigations, the obtained effects allow for the following speculation. When the search display was presented, both the irrelevant singleton and the target evoked saliency signals as they both were singletons that contrasted with the surrounding distracters. Hence, saliency signals from two dimensions (color and shape) were being transmitted to the priority map. According to the postulated model of perceptual processing, focal attention is guided to those locations in the visual field that are

represented by the highest activity on the priority map, with other locations being attended in the order of decreasing activity levels. The present results (the search display-induced N2pc and the probe-locked P1) showed that attention was successfully allocated to the target and not to the irrelevant singleton. Therefore, the highest peak of activity at the priority map must have occurred for the target and not for the irrelevant singleton. This could not solely be due to saliency signals, as the target was less salient than the irrelevant singleton. Hence, the singleton dimension must have been weighted with respect to task relevance before the saliency signals were summed and calculated at the level of priority map. Weighting the task-relevant dimension higher (and, possibly also down-weighting signals on the irrelevant dimension) resulted in a higher activation peak at the priority map for the target compared to the irrelevant singleton, although the latter was more salient. It is important to note that because N2pc and P1 are components related to *spatial* attention, the present results presumably indicated the allocation of attention after computations on the priority map-level and not the earlier weighting process. As it takes some time until priority map computations are completed, the present target-related effects were observed relatively late.

In summary, results of the present experiment speak in favor of top-down influence on saliency-based processing. The human perceptual system is capable of guiding focal attention to task-relevant items even if a strongly interfering signal is present in the visual field.

### Acknowledgments

This research was supported by the Deutsche Forschungsgemeinschaft (German Research Foundation, Research Group FOR 480, TP 5). We thank Niko Busch for valuable comments on an earlier version of this article and Anne-Lene Kurz for her help with data collection.

Reprint requests should be sent to Agnieszka Wykowska, Department of Psychology, Ludwig-Maximilian University, Leopoldstr. 13, D-80802 Munich, Germany, or via e-mail: wykowska@psy.uni-muenchen.de.

### Notes

- Note that although in our experiment the search display was removed and followed by a blank screen before the probe was presented, we use the term SOA to denote the time interval between the onset of the search display and the onset of the probe.
- One could argue that results related to displays with two singletons should be interpreted cautiously as the same hemifield condition and the opposite hemifield condition are not physically identical. In effect, differences in ERPs might be due to the imbalance in sensory energy and not to attentional modulations. Nevertheless, it is rather unlikely that such physical difference would influence the later component typically related to attention effects (N2pc) without influencing earlier components (for similar arguments, see Hickey et al., 2006). Moreover, even if one was to put forward such an alternative explanation, it could not be applied to the effects of top-down guidance of at-

tention that are essential to the present argumentation. These top-down effects do not rely on the comparison between same hemifield versus opposite hemifield conditions.

### REFERENCES

- Bacon, W. F., & Egeth, H. E. (1994). Overriding stimulus-driven attentional capture. *Perception & Psychophysics*, *55*, 485–496.
- Duncan, J., & Humphreys, G. W. (1989). Visual search and stimulus similarity. *Psychological Review*, *96*, 433–458.
- Eimer, M. (1996). The N2pc component as an indicator of attentional selectivity. *Electroencephalography and Clinical Neurophysiology*, *99*, 225–234.
- Folk, Ch. L., & Remington, R. (1998). Selectivity in distraction by irrelevant featural singletons: Evidence for two forms of attentional capture. *Journal of Experimental Psychology: Human Perception and Performance*, *24*, 847–858.
- Folk, Ch. L., & Remington, R. (2006). Top-down modulation of preattentive processing: Testing the recovery account of contingent capture. *Visual Cognition*, *14*, 445–465.
- Folk, Ch. L., Remington, R., & Johnston, J. C. (1992). Involuntary covert orienting is contingent on attentional control settings. *Journal of Experimental Psychology: Human Perception and Performance*, *18*, 1030–1044.
- Found, A., & Müller, H. J. (1996). Searching for unknown feature targets on more than one dimension: Investigating a “dimension weighting” account. *Perception & Psychophysics*, *58*, 88–101.
- Geyer, T., Müller, H. J., & Krummenacher, J. (2008). Expectancies modulate attentional capture by salient color singletons. *Vision Research*, *48*, 1315–1326.
- Hickey, C., McDonald, J. J., & Theeuwes, J. (2006). Electrophysiological evidence of the capture of visual attention. *Journal of Cognitive Neuroscience*, *18*, 604–613.
- Hillyard, S. A., Vogel, E. K., & Luck, S. J. (1998). Sensory gain control (amplification) as a mechanism of selective attention: Electrophysiological and neuroimaging evidence. *Philosophical Transactions of the Royal Society of London, Series B, Biological Sciences*, *353*, 1257–1270.
- Hopfinger, J. B., & Mangun, G. R. (1998). Reflexive attention modulates processing of visual stimuli in human extrastriate cortex. *Psychological Science*, *9*, 441–446.
- Jolicoeur, P., Sessa, P., Dell’Acqua, R., & Robitaille, N. (2006). Attentional control and capture in the attentional blink paradigm: Evidence from human electrophysiology. *European Journal of Cognitive Psychology*, *18*, 560–578.
- Kim, M. S., & Cave, K. R. (1999). Top-down and bottom-up attentional control: On the nature of interference from a salient distractor. *Perception & Psychophysics*, *61*, 1009–1023.
- Lamy, D., Tsai, Y., & Egeth, H. E. (2003). Does a salient distractor capture attention early in processing? *Psychonomic Bulletin & Review*, *10*, 621–629.
- Lien, M. C., Ruthruff, E., Goodin, Z., & Remington, R. W. (2008). Contingent attentional capture by top-down control settings: Converging evidence from event-related potentials. *Journal of Experimental Psychology: Human Perception and Performance*, *34*, 509–530.
- Luck, S. J. (2005). *An introduction to the event-related potential technique*. Cambridge, MA: The MIT Press.
- Luck, S. J., Fan, S., & Hillyard, S. A. (1993). Attention-related modulation of sensory-evoked brain activity in a visual search task. *Journal of Cognitive Neuroscience*, *5*, 188–195.
- Luck, S. J., & Hillyard, S. A. (1994). Spatial filtering during visual search: Evidence from human electrophysiology. *Journal of*

- Experimental Psychology: Human Perception and Performance*, 20, 1000–1014.
- Luck, S. J., Woodman, G. F., & Vogel, E. K. (2000). Event-related potential studies of attention. *Trends in Cognitive Sciences*, 4, 432–440.
- Mangun, G. R., Hillyard, S. A., & Luck, S. J. (1993). Electrocortical substrates of visual selective attention. In D. Meyer & S. Kornblum (Eds.), *Attention and performance* (Vol. XIV, pp. 219–443). Cambridge, MA: MIT Press.
- Müller, H. J., Heller, D., & Ziegler, J. (1995). Visual search for singleton feature targets within and across feature dimensions. *Perception & Psychophysics*, 57, 1–17.
- Müller, H. J., Reimann, B., & Krümmenacher, J. (2003). Visual search for singleton feature targets across dimensions: Stimulus- and expectancy-driven effects in dimensional weighting. *Journal of Experimental Psychology: Human Perception and Performance*, 29, 1021–1035.
- Posner, M. I. (1980). Orienting attention. *Quarterly Journal of Experimental Psychology*, 32, 3–25.
- Schubö, A., Schröger, E., & Meinecke, C. (2004). Texture segmentation and visual search for pop-out targets. An ERP study. *Cognitive Brain Research*, 21, 317–334.
- Schubö, A., Wykowska, A., & Müller, H. J. (2007). Detecting pop-out targets in contexts of varying homogeneity: Investigating homogeneity coding with event-related brain potentials (ERPs). *Brain Research*, 1138, 136–147.
- Theeuwes, J. (1992). Perceptual selectivity for color and form. *Perception & Psychophysics*, 51, 599–606.
- Theeuwes, J., Atchley, P., & Kramer, A. F. (2000). On the time course of top-down and bottom-up control of visual attention. In S. Monsell & J. Driver (Eds.), *Attention and performance XVIII: Control of cognitive performance* (pp. 105–124). Cambridge, MA: MIT Press.
- Theeuwes, J., Reimann, B., & Mortier, K. (2006). Visual search for featural singletons: No top-down modulation, only bottom-up priming. *Visual Cognition*, 14, 466–489.
- Van Zoest, W., Donk, M., & Theeuwes, J. (2004). The role of stimulus-driven and goal-driven control in saccadic visual selection. *Journal of Experimental Psychology: Human Perception and Performance*, 30, 746–759.
- Wolfe, J. M. (1994). Guided Search 2.0: A revised model of visual search. *Psychonomic Bulletin & Review*, 1, 202–238.
- Wolfe, J. M., Butcher, S. J., Lee, C., & Hyle, M. (2003). Changing your mind: On the contributions of top-down and bottom-up guidance in visual search for feature singletons. *Journal of Experimental Psychology: Human Perception and Performance*, 29, 483–502.
- Woodman, G. F., & Luck, S. J. (2003). Serial deployment of attention during visual search. *Journal of Experimental Psychology: Human Perception and Performance*, 29, 121–138.
- Yantis, S., & Jones, E. (1991). Mechanisms of attentional selection: Temporally modulated priority tags. *Perception & Psychophysics*, 50, 166–178.